

ON CONSONANT SEQUENCES IN CAYUGA (IROQUOIAN)

Carrie Dyck
Memorial University of Newfoundland

ABSTRACT

Underlying consonant sequences in Cayuga (and in other Northern-Iroquoian languages) are apparently subject to phonotactic constraints. The non-randomness of underlying consonant sequences is problematic for Optimality-Theory (OT), which assumes that inputs are unconstrained (Prince & Smolensky 1993; Smolensky 1995). However, I show that apparent phonotactic constraints are the product of the interaction of output-based constraints: I claim that the output optimally conforms to a group of ranked constraints on syllable structure which conspire to produce a CV(V)C syllable template. The CV(V)C template predicts a maximum of two consonants word-medially; problematically, larger word-medial sequences exist. Nevertheless, the alternative of positing a larger template (such as CCV(V)C) is undesirable: doing so predicts too few sites of epenthesis. Consequently, I adopt the smaller CV(V)C template and propose two explanations for the larger (3+) word-medial sequences: first, some larger sequences are subject to MERGE; that is, continuant segments in such sequences are phonetically realized as secondary articulations rather than as full segments. As a consequence, word-medial consonant sequences contain at most two stop segments (plus some continuant segments which are realized as secondary articulations). Second, exceptionally large consonant sequences containing three stops can be licensed in the Cayuga verb because the verb is a prosodic phrase (ϕ) potentially containing several prosodic words (ω). Each prosodic word within the verb can have an appendix in which an extra (third) stop consonant can be licensed. In summary, Cayuga has a CV(V)C template which licenses a maximum of 2 consonants word-medially; nevertheless, because of underparsing (MERGE) and verb-internal appendices, larger sequences can be realized within the verb.

1. INTRODUCTION*

Underlying consonant sequences in Cayuga (and in other Northern-Iroquoian languages) are apparently subject to phonotactic constraints. For example, large sequences typically contain /h/, /ʔ/, /s/, [w], or [y] (see Michelson's tables of consonant sequences in Mohawk, Oneida, Onondaga, Cayuga and Seneca; Michelson 1988: 12, 17, 20, 22, 23). The non-random nature of underlying consonant sequences is problematic for the Optimality-Theoretic (OT) approach, which assumes that inputs are unconstrained (Prince & Smolensky 1993; Smolensky 1995). However, I

will show that apparent phonotactic constraints are the product of the interaction of output-based constraints. Specifically, I claim that the output must syllabify into a CV(V)C template (in OT terms, must optimally conform to a group of ranked constraints on syllable structure).

The CV(V)C template predicts a maximum of two consonants word-medially; problematically, larger word-medial sequences exist. Nevertheless, the alternative of positing a larger template (such as CCV(V)C) is undesirable: doing so predicts too few sites of epenthesis. Consequently, I adopt the smaller CV(V)C template and propose two explanations for the larger (3+) word-medial sequences: first, some larger sequences are subject to MERGE; that is, they are realized phonetically as singletons. (See Dyck 1990, Doherty 1993, and Steriade 1994 for similar accounts.) Second, other large consonant sequences exist because the Cayuga verb-word is prosodically complex; I claim that the Cayuga verb is a prosodic phrase (ϕ) potentially containing several prosodic words (ω). (Following Selkirk: (1978), McCarthy and Prince (1986), and others, I assume the prosodic hierarchy μ mora— σ syllable—F foot— ω prosodic word— ϕ prosodic phrase.)

The paper proceeds as follows: §2 outlines assumptions; §3 provides the phonemic inventory of Cayuga; §4 lists the consonant sequences occurring in Cayuga; §5 argues for a CV(V)C template and discusses the problem of

* I would like to thank Elan Dresher, Karin Michelson, Keren Rice, two anonymous reviewers from IJAL, and two anonymous reviewers from *Linguistica Atlantica* for comments and suggestions which greatly improved this paper. The Cayuga examples in this paper were provided by E. Jamieson, F. Froman, A. Keye, L. Keye, and the late Reg Henry. Nyá:wəh. All errors and omissions are my own. This work was partly funded by a Memorial University of Newfoundland Dean of Arts Internal Award, SSHRCC Postdoctoral research fellowship #756-94-0716, and also SSHRCC Research Grant #410-92-1885 to Elan Dresher and Keren Rice.

Abbreviations used in this paper include: DUAL 'dualic', PROTH 'prothetic vowel', FUT 'future', NEG 'negative', FACT 'factual', OPT 'optative', TRANS 'translocative', CISL 'cislocative', PUNC 'punctual', HAB 'habitual', ASP 'unspecified aspect suffix', SEMI 'semireflexive', RFL 'reflexive', NSF 'noun stem former', EPEN 'epenthetic vowel', INSTR 'instrumental', DEC 'decessive', TYP 'typicalizer', CUST 'customary', YOU.S 'you (singular)', YOU.PL 'you (plural)', WE.ALL '1 inclusive plural', I '1 singular', THEY.(M) '3 masculine plural', HE '3 masculine singular', IT '3 zoic-neuter', SHE '3 feminine-indefinite' The feminine-indefinite prefix /e-/ has several usages, and can be translated as 'she' or as a generic 'someone.' Prothetic [i] occurs whenever a verb would otherwise have only one vowel.

syllabifying 3+ sequences; §6-7 argues that continuant segments can be realized as secondary articulations (can be subject to MERGE) in 3+ consonant sequences; §8-10 outline how sequences are syllabified, assuming MERGE; §11-12 argues that some larger sequences can be retained because of the prosodic structure of the Cayuga verb; §13-14 summarize the account and compare it with previous input-based accounts.

2. ASSUMPTIONS

Assumptions used in the paper include the concepts of core and non-core syllabification, the Sonority Sequencing Principle (henceforth SSP; see Clements 1990 for a comprehensive treatment of the SSP), and the prosodic hierarchy. These are outlined below.

The SSP requires segments to syllabify such that sonority rises towards the nucleus, and falls towards the margins of the syllable. Core syllabification is a consequence of the SSP.

I assume the following sonority scale:

(1) Sonority scale:

[low vowels > mid vowels, ʔ, h > high vowels, w, y > r > n > t, k, s]

Of special note is the sonority assigned to the laryngeals. I assume that the laryngeals are [-high] approximants or glides (Chomsky & Halle 1968: 303, 307). Given this assumption, the relative sonority of the laryngeals can be determined by referring to the vocalic sonority scale: low vowels are more sonorous than mid vowels, which are in turn more sonorous than high vowels (Jespersen, as reported in Malmberg 1963, cited in Hooper 1974). Thus, in general, as summarized in (2), [-high] segments are more sonorous than [+high] segments.

- (2) a. [-consonantal, +low, -high] (low vowels) >
 b. [-consonantal, -low, -high] (mid vowels, laryngeals) >
 c. [-consonantal, -low, +high] (high vowels, [w,y] > etc.

Thus, the laryngeals are more sonorous than [w, y], but less sonorous than the low vowels.

Non-core syllabification involves parsing consonant sequences which would violate the SSP (e.g., sequences of equal sonority). Segments in such sequences are typically parsed into appendices to the prosodic word (Booß & Rubach 1987). I claim that Cayuga syllabifies an extra consonant word-initially into an appendix (see §11).

Segments not licenced through core or non-core syllabification either delete through Stray Erasure, or trigger epenthesis. Cayuga employs Stray Erasure word-finally (see §4.4) and epenthesis [e] in order to syllabify some of the larger sequences (see §5.3).

3. THE PHONEMIC INVENTORY

The phonemes of Cayuga are listed in (3).

(3) Cayuga phonemes

/t/	/k/	/l: ^w /	/i/[y]	(/u/)[w]
/s/	/h/	/ʔ/	/e/	/o/
/n/			/ɛ/	/ɔ/
/r/			/a/	

/ɔ/ is a mid back rounded nasalized vowel and /ɛ/ is a lower-mid front unrounded nasalized vowel. /u/ is a marginal phoneme.²

¹ The following examples illustrate that /k^w/ and /k/ are distinct phonemes. (Underlining of a vowel indicates devoicing; phonetic realizations of /k/ and /k^w/ are highlighted in square brackets).

- (i) a. The phoneme /k^w/, which is realized as [k^w ~ k]
- | | |
|---|-----------------------------------|
| o <u>h</u> sóh[k ^w]a [?] | ka <u>s</u> óh[k]ɔ:t |
| o-hsohk ^w -a [?] | ka-hsohkw-ɔt |
| IT-lip-NS [?] | IT-lip-attached.ASP |
| 'lips' | 'a pitcher (lit.: attached lips)' |
- (i) b. versus the sequence /k/ and [w], which is realized as [kw ~ ky]
- | | |
|-------------------------------|--------------------------|
| ɔ[k ^w]anɔhɔktanih | ɔ[ky]ɔtsanɔhwa:s |
| ɔkwa-nɔhɔktanih | ɔkw-ɔtsa-nɔhwa:s |
| WE.ALL-sick.ASP | WE.ALL-knee-sore.ASP |
| 'we all are sick' | 'we all have sore knees' |

As shown in (i.a.), the labialization in /k^w/ deletes before round vowels; in contrast, (i.b.) illustrates that the independent segment [w] is realized as a [y] before round vowels. (In (i.b.), the /a/ of the morpheme /ɔkwa-/ deletes, leaving [w] adjacent to the vowel /ɔ/ of the following morpheme. This triggers the change from [w] to [y]. (See Postal 1969, Michelson 1988: 32-41 for discussion of vowel deletion in Mohawk, a related language.)

² Examples of /u/ are given in (ii):

- (ii) Marginal /u/:
- | | |
|---|-------------------|
| a. niwú: [?] uh | 'how small it is' |
| b. niwu [?] trukyé: [?] ah | 'it is narrow' |
| c. tuwístuwi: [?] | 'a killdeer' |
| d. ohyu [?] thí:yeht, ohyo [?] thí:yeht | 'it is sharp' |
| e. taku:s, t [?] ko:s | 'a cat' |

4. CONSONANT SEQUENCES

The consonant sequences of Cayuga are listed in the following section; sequences are compiled from Michelson (1988: 21-22), Mithun & Henry (1982), and from examples by the speakers cited in the acknowledgements.

4.1. Word-initial consonant sequences

Word-initial consonant sequences are listed in (4).

(4) Word-initial consonant sequences:

C2 →	y	w	r	n	t	k	s	h	?
C1 ↓									
w,y,r									
n								(nh) ³	
t	ty	tw	tr	tn ⁴		tk	ts	th	
							tsh		
							tsy		
k	ky	kw	kr	kn	kt			kh	
s	sy	sw	sr	sn	st	sk		sh	
						skr			
h									
?									

Word-initially, there are sequences of rising sonority (such as ty, tw, tr and tn), sequences of equal sonority (such as tk, and ts) and some larger se-

Non-alternating /u/ occurs in very few morphemes; the most commonly occurring are shown in (ii. a-c). Otherwise, the choice of [u] or [o] is a matter of speaker preference (Mithun & Henry: 7); the two possible pronunciations are shown in (ii. d, e).

- ³ The sequence /nh/ occurs word-initially only in the particle written as *hə* or *n h ə*. (This particle occurs in combination with other particles with resultant meanings such as 'where', 'there', 'somewhere', etc.) Cayuga speakers debate the spelling of the particle, but current consensus is that the spelling *hə* is more correct. The debate minimally indicates that the status of word-initial /nh/ is doubtful.
- ⁴ Sequences of stops such as /tn/, /kn/, /tk/ and /kt/ are realized as [t^hn], [k^hn], [t^hk], and [k^ht], with aspiration between the first and second members of each sequence. Aspiration between /tn/ and /kn/ is often (but not consistently) indicated in the writing system; thus <thn> and <khn> are common spellings. (Angle brackets indicate spellings.) The process of inserting aspiration between /tn/ and /kn/ is known as 'h-epenthesis' in the literature

quences (tsh, tsy, and skr); all of the latter include a continuant segment. There are no sequences of falling sonority word-initially.

4.2. Word-medial consonant sequences

Word-medial consonant sequences are listed in (5):

(5) Word-medial consonant sequences:

C2 →	y	w	r	n	t	k	s	h	ʔ
C1 ↓									
w,y,r									
n	nyʔ		nr						
t	ty		tr			tk	ts	th	tʔ
						tkw	tsy	thw	
						tkhw	tsh	thy	
						tkt		thr	
						tkn		thn	
						tsn			
k	ky		kr		kth		ksh	kh	kʔ
								khn	
s	sy	sw	sr	sn		skw	sh		sʔ
h				hn ⁵	ht	hk	hs		
				hnh	htk	hk ^w	hsh		
				hny	hth	hkr	h ^{sr}		
					hthw	hkhw	hsth		
							hsʔ		
ʔ					ʔt	ʔk	ʔs	ʔh	
					ʔth	ʔkh	ʔsh		
					ʔthr	ʔksk			

Word-medially, there are sequences of rising sonority (e.g., tr, ky) and of equal sonority (e.g., tk, ts). However, apart from sequences beginning

(Chafe & Foster 1981: 136; Michelson 1988: 24-5). A fact not mentioned in the Iroquoian literature is that h-epenthesis also occurs in /tk/ and /kt/ sequences, which are realized as [t^hk] and [k^ht].

- 5 The apparently word-initial sequences /hn/ and /hny/ are reanalysed as being word-medial for the following reasons: the relevant sequences occur in the particle *hniʔ* 'and', and in the words *hnyákwaiʔ* 'bear', *hnáʔgɔhka:ʔ* 'underwear', and *hnyóʔɔh* 'the colour white'. However, all of these words except for *hniʔ* are defective because they are missing a pronominal prefix (such as /o-/); evidence is that: (a) accent placement in these words is regular

with laryngeals (e.g., ht, hk), there are no sequences of **falling** sonority. Additionally, most of the larger sequences contain /h/, /s/, /ʔ/, [w] or [y]; however, a few of the larger sequences such as /tkt/ and /tkn/ contain three stop obstruents. A word illustrating the sequence /tkt/ is shown in (6). (For reasons explained in §11, the boundary between the mixed group known as the **prepronominal** prefixes and the uniform group of **pronominal** prefixes is marked with a number sign # in all relevant examples.)

- (6) itktaʔk⁶ [Mithun & Henry 1982: 567]
 i-t#k-taʔ-k
 PROTH-CISL-I-stand.up-MODALIZER
 'I was standing there'

Significantly, the /tkt/ sequence occurs after a prothetic vowel; I will argue in §11 that words with prothetic vowels (and ultimately, Cayuga verbs in general) are prosodically complex; the presence of larger sequences such as /tkt/ can be explained with this assumption.

4.3. Word-final consonant sequences

Word-final consonant sequences (and related alternations) are summarized in (7). Some underlying word-final consonants, listed in brackets, are deleted in surface form. Word-finally, there are surface consonant sequences of falling sonority only. Furthermore, such sequences only begin with a laryngeal; otherwise, only singletons occur word-finally. The type of singleton that can occur word-finally is also constrained in that /n/, [w], and [y] are absent. (/r/ does not occur word-finally.) This observation is discussed further in the following section.

only if we assume an underlying word-initial vowel (i.e., a prefix such as /o-/) that is deleted 'after' accent placement; (b) related words have a pronominal prefix such as /o-/ before the /hn/ and /hny/ sequences; and (c) pronominal prefixes such as /o-/ can delete, viz. [ohɔnaʔtaʔ, hɔnaʔtaʔ] 'potato', and [ohskwæʔtaʔ, skwæʔtaʔ] 'coltsfoot'. In summary, although the sequences /hn/ and /hny/ appear to be word-initial, they are word-medial in underlying form.

⁶ Aspiration (known as h-epenthesis) occurs between each of the stops in the /tkt/ sequence.

(iii)	i:ke[:s] i#k-e-k-s PROTH-I-EPEN-eat-HAB 'I eat'	cf. (iv)	é:ke:[k] e#k-e-k-? FUT-I-EPEN-eat-PUNC 'I will eat'
-------	--	----------	--

For example, in (8a. iii), final /t/ in the sequence /ʔkt/ is deleted. In contrast, in (8b. i), final /s/ is retained in the /ts/ sequence. Also, as shown in the examples in (8b), final consonant deletion can result in Compensatory Lengthening (CL); CL also occurs in later examples.

4.4. Word-final deletion and compensatory lengthening of sonorants

As mentioned earlier, the type of singleton that can occur word-finally is highly constrained: word-finally /n/, [w], and [y] delete with CL, while /ʔ/ is maintained. For example, in (9a), morpheme-final [w] is preserved by the addition of a (habitual aspect) suffix but deletes with CL before the punctual aspect suffix (/ʔ-ʔ/).

(9) Word final deletion of /n,w,y/:

a.	deletion of [w]: kraké:[w]ahs k-rakew-ahs I-erase-HAB 'I am erasing, wiping'	cf.	ekrá:ke[:]? e#k-rakew-? FUT-I-erase-PUNC 'I will erase, wipe'
b.	deletion of /n/: khré:[n]ahs k-hren-ahs I-cut-HAB 'I cut it all the time'	cf.	eḵhre[:]? e#k-hren-? FUT-I-cut-PUNC 'I will cut it'
c.	deletion of [y]: hḗhé:[y]ḡhs ha-ihey-ḡhs HE-die-HAB 'he is dying'	cf.	eḵíhe[:]? e#k-ihey-? FUT-I-die-PUNC 'I will die'

These and earlier observations show that laryngeals differ from other sonorants: 1) word-finally, laryngeals are retained while other sonorants are deleted; 2) elsewhere, the only possible sequences of falling sonority begin with a laryngeal.

4.5. SUMMARY

General observations which can be drawn from §4.1-4.4 concern sequences and singletons. First, regarding sequences: 1) sequences of rising sonority occur word-initially and word-medially; however, word-finally,

such sequences are simplified to singletons; 2) apart from sequences beginning with laryngeals, sequences of falling sonority do not exist: there are no such sequences beginning with [w], [y] or /r/; 3) sequences of equal sonority occur word-initially and word-medially; however, word-finally, one consonant deletes in such sequences; and 4) larger (3+) sequences usually contain the continuants /h/, /s/ /ʔ/, [w] or [y]; the exceptions (sequences containing three stop segments) occur in a prosodic environment to be discussed in §11.

Second, regarding singletons: 1) [w] and [y] never appear in coda position; and 2) /n/ occurs in coda position only in two sequences of rising sonority (/ny/ and /nr/). Thus, Cayuga disprefers prototypical sonorant codas.⁸ While this fact deserves further analysis, for the purposes of this paper the coda condition is not relevant (because it applies to singletons), except to the extent that the prohibition against sonorant codas needs to be assumed. In remaining sections, I focus on explaining how consonant sequences syllabify within the CV(V)C template in Cayuga, leaving the problem of coda conditions for future study.

5. THE CV(V)C SYLLABLE TEMPLATE

Unlike previous accounts, I propose that Cayuga has a CV(V)C syllable template which maximally syllabifies two-consonant sequences. Several arguments against assuming a larger template with either a complex coda or complex onset are presented below.

5.1. Against a complex coda

The presence of a complex coda in Cayuga is ruled out because, as discussed in §4.4, there are no consonant sequences of falling sonority either underlyingly or in surface forms; such sequences would form prototypical complex codas, yet none exist. (Sequences of falling sonority which begin with a laryngeal are not counterexamples; syllabification of such sequences is discussed in §8.1.)

5.2. Against complex onsets: accentual phenomena

Because Cayuga has surface consonant sequences of rising sonority, assuming a complex onset initially appears plausible. However, compelling evidence against a complex onset is that, for the purposes of accent placement, the first consonant of **any** two-consonant sequence **closes** a syllable

⁸ Melinger (1997: 44) notes that the same condition holds in Seneca.

(Chafe 1977: 176; Dyck 1997; Foster 1982: 60). This generalization applies to sequences such as [t.r] (where a period indicates a syllable boundary), even though /tr/ could be syllabified as a complex onset.

5.3. Against complex onsets: epenthesis facts

A second argument against complex onsets involves the syllabification of sequences such as /tkw/. If the template were CCV(V)C, these should parse into a coda followed by a complex onset, i.e., as [t.kw]. However, assuming a CCV(V)C template predicts too many possible consonant sequences and too few sites of epenthesis. As table (10) shows, a putative CCV(V)C template predicts 27 possible surface consonant sequences; however, only two such sequences occur in surface forms, viz. /tkw/ and /tsy/, which are bolded in (10):

- (10) Actual surface consonant sequences and those predicted by a CCV(V)C template:

Onset →	tw	ty	tr	kw	ky	kr	sw	sy	sr
Coda ↓									
t	t.tw	t.ty	t.tr	t.kw	t.ky	t.kr	t.sw	t.sy	t.sr
k	k.tw	k.ty	k.tr	k.kw	k.ky	k.kr	k.sw	k.sy	k.sr
s	s.tw	s.ty	s.tr	s.kw	s.ky	s.kr	s.sw	s.sy	s.sr

(Note for future reference that the two extant sequences end with continuant segments.)

Some of the sequences predicted in (10) **do** occur underlyingly as a result of morpheme concatenation; however, as shown in (11), these are subject to e-epenthesis.⁹

- (11) e-epenthesis examples (non-underlying epenthetic [e] is included in the morpheme breakdown):

- a. o[tetr]ɛnái?
o-t-trɛna-i?
IT-SRF-odour-be.stuck.to.s.t.
'an odour'
- b. [ketr]ɛ:ní:yo:
k-trɛ:n-i:yo:
I-odour-nice
'I smell nice'

⁹ Example (11) lists all the combinations of two obstruents plus a glide or liquid for which I could find examples in an 8000-word database.

- c. a[kékʷ]aɔt
 ak-kwa-ɔt
 I-boil-attached
 'I have an abscess, a boil'
- d. tesá[tesw]aht
 te#s-at-swaht
 DUAL-2OUS-SRF-smell.something
 'you smell it'
- e. a[kesw]ahskéheʔ
 ak-swa:hs-kéheʔ
 I-smell.HAB-FORMER
 'I used to be able to smell (but my nose quit working)'

The examples in (11) show that underlying sequences of two obstruents followed by a glide or liquid **can** be subject to epenthesis. I will not explain why sequences such as /tkw/ fail to trigger epenthesis, while sequences such as /kkw/ **are** subject to epenthesis. (An OCP-based account would allow [tkw] but not [kkw].) It is clear, however, that sequences of three consonants are dispreferred, and that positing a complex onset incorrectly predicts no epenthesis whatsoever.

In summary, on the one hand, a larger CCV(V)C template is undesirable; on the other hand, a smaller CV(V)C template is apparently too small to accommodate sequences of more than two consonants—at first glance, for example, it does not explain why /tkw/ sequences fail to trigger epenthesis.

5.4. Fitting large consonant sequences into a small template

In order to reconcile the presence of large consonant sequences with a small syllable template, I propose that some consonant sequences can parse as singletons in constrained environments (see also Dyck 1990; Doherty 1993; Steriade 1994). This type of parsing is referred to as MERGE throughout the paper. MERGE allows continuant segments to be realized as secondary articulations: underlying /h/ can be realized as aspiration [h̥], underlying /ʔ/ as glottalization [ʔ̥], underlying /s/ as frication [s̥], [w] as labialization [w̥], and [y] as palatalization [y̥]. MERGE has desirable consequences, making it possible to adopt a more constrained CV(V)C syllable template which better predicts the sites of epenthesis and the distribution of consonants in underlying sequences. Arguments that there are two possible parses (merged and non-merged) for certain segments are presented below.

6. THE REALIZATION OF LARYNGEALS

The realization of postvocalic laryngeals (reviewed below) provides evidence that the laryngeals can be parsed either as full segments or as secondary articulations.

6.1. In lengthening environments

In lengthening environments (i.e., in tonic or pretonic position), '...a sequence /Vʔ/ is realized as [V̄V], i.e., as a long vowel with a change in voice quality from modal voice to creaky voice.' (Doherty 1993: 107). In the sequence /Vh/, the second portion of the long vowel is voiceless (*ibid.*). Thus, phonetically, laryngeals in lengthening environments are realized as non-modally voiced vowels; in other words, they are realized as full segments.

Also in lengthening environments, both Tonic Lengthening (of the accented vowel) and Pretonic Lengthening (of the pre-accented vowel) fail to occur when the relevant syllables contain /h/ or /ʔ/.¹⁰ Assuming that the la-

¹⁰ According to traditional descriptions, the lengthening processes also fails to occur when a syllable is closed by an /s/ (in an /s.t/ cluster). This observation is not supported by phonetic evidence: Doherty's acoustic measurements show that lengthening **does** in fact occur when /s/ closes the syllable (1993: 187ff). Examples that I have collected support Doherty's observations; an example of lengthening before /st/ is shown in (iii):

- (iii) Lengthening before /st/
 otetakwá:stəh 'it is bruised'
 o-tat-akwastəh
 IT-RFL-bruised.ASP

However, Doherty does point out two possible counterexamples to his claim that /s/ does not prevent lengthening, namely tokens containing [st] sequences in which lengthening apparently fails to occur. Doherty hypothesizes that the problematic tokens actually contain phonemic /hst/ sequences and have been mistranscribed with [st] rather than with [hst]. In words containing /hst/ sequences, lengthening would be prevented by /h/ (and **not** by /s/); as discussed in §6.1, /h/ would syllabify into the nucleus, while /s/ would syllabify into the coda, and /t/ into the onset. Thus, if the problematic tokens actually contained underlying /hst/, then they would not be exceptional.

My own examples of the same words support Doherty's explanation; the tokens in question are unexceptional; they have /hst/ sequences rather than /st/ sequences and the transcription [st] is incorrect.

Based on the above arguments, I conclude that /s/ does **not** pattern like the laryngeals with respect to lengthening.

ryngeals are full segments in lengthening environments, vowels preceding a laryngeal cannot lengthen because the second nuclear position is already filled by a laryngeal (i.e., by a non-modally-voiced vowel).

Thus, the laryngeals should be analysed as full segments in lengthening environments. In contrast, in other environments, the laryngeals are parasitically realized as laryngealization, as discussed below.

6.2. In non-lengthening environments

In non-lengthening environments, the manner of realization of laryngeals is dependent on whether or not Laryngeal Metathesis (LM) applies: LM applies to metrically-weak syllables (i.e., to syllables which are odd-numbered, counting from the left edge of the word; see Chafe 1977: 177-178; Foster 1974: 260-5, 1982: 68-71; Lounsbury 1963: 565-569). The entire syllable is affected by LM: syllables closed by /h/ are realized with a short, devoiced vowel; /CVh/ is pronounced [CʰV̥]. Syllables with /ʔ/ are pronounced with a short, creaky-voiced vowel; /CVʔ/ is pronounced as [CʰV̥]. Furthermore, the onsets of syllables containing /h/ are devoiced and/or aspirated, while the onsets of syllables containing /ʔ/ are glottalized.¹¹ As these observations show, in LM environments, the laryngeal quality is spread throughout the entire syllable rather than being localized in one segment. Thus, the laryngeals are not discrete segments in LM environments, but are instead realized as non-modal voicing superimposed on other segments.

In non-lengthening environments where LM **fails** to apply, /h/ is pronounced as [h] and /ʔ/ as a glottal catch or single 'creak' following the vowel. While nothing special can be said about [h] in this environment, the realization of /ʔ/ is telling: /ʔ/ is realized as **laryngealization**, which is: '...an articulatory tendency to create a glottal constriction, which normally fails nevertheless to reach the maximum stricture of a full glottal stop.' (Laver 1994: 330). Significantly, laryngealization is unlike a full segment such as /ʔ/; the former's realization is more 'parasitic' on that of other segments (Laver 1994: 330).

6.3. Variable realization

As shown above, the laryngeals are realized as full segments when they are in lengthening environments; in contrast, they are realized parasitically in non-lengthening environments. This point is illustrated further in

¹¹ Glottalization is more salient when the onsets are sonorants.

the following diagram, which shows how laryngeal articulations are timed with respect to other segments in Cayuga.

(12) Coarticulation of laryngeals and other segments:

- Key: a. Lengthening environments
 b. Non-lengthening LM environments
 c. Non-lengthening, non-LM environments

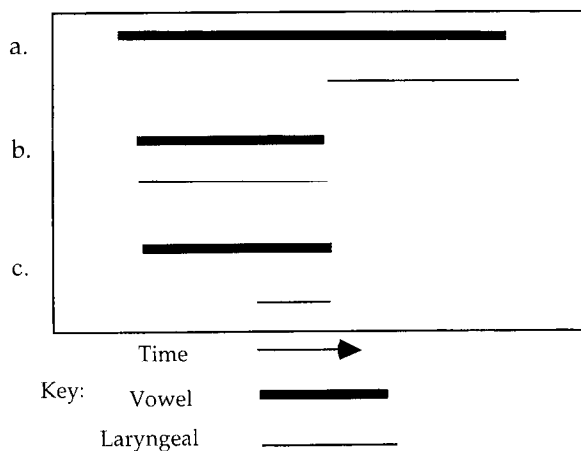

In lengthening environments (12a), laryngeal or non-modal voicing is concurrent with the second half of a long vowel. In non-lengthening, LM environments (12b), laryngeal or non-modal voicing is concurrent with the entire short vowel (and thus also affects the pronunciation of the syllable onset); in non-lengthening, non-LM environments (12c), non-modal voicing (or laryngealization) is limited to the second half of a short vowel and is parasitically realized on the vowel.

6.4. Merge of /h/ and /ʔ/

The phonetic evidence reviewed above shows that the laryngeals can be parsed in two distinct ways. When parsed as full segments, laryngeals have the representation shown in (13): in feature-geometry terms (see Clements & Hume 1995), the laryngeals have their own root node (\bullet), laryngeal node (L), and laryngeal feature ([CG] or [+Constricted Glottis] for /ʔ/), ([SG] or [+Spread Glottis] for /h/).

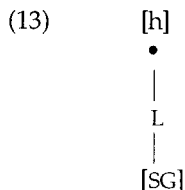

In contrast, when parsed as secondary articulations, laryngeals have the representation shown in (14), where the laryngeal lacks an independent root node. ([l̥] denotes non-laryngeal features.)

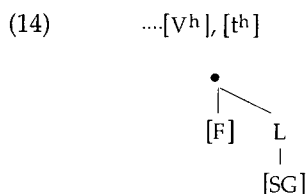

Example (14) illustrates either a vowel or consonant to which a laryngeal has parsed as a secondary articulation.

In Optimality Theoretic terms, laryngeals will parse as secondary articulations whenever other, more highly ranked constraints require it.¹² I claim in this paper that laryngeals can parse as secondary articulations, but only in larger consonant sequences so that all members of a sequence can be realized. The mechanism of (under) parsing segments as secondary articulations will be referred to as MERGE:

(15) MERGE: (under)parse segments as secondary articulations

Example syllabifications assuming MERGE are provided in §9-11. First, however, I discuss the implications of MERGE for other continuant segments.

7. MERGE OF [w], [y], AND /s/

I propose that it is also phonologically advantageous (and consistent with articulatory facts) to merge [w], [y], and /s/ as secondary articulations

¹² The constraints which require laryngeals to parse as secondary articulations in LM environments are not discussed in this paper. (See Dyck 1997.) In brief, foot well-formedness constraints enforce a type of iambic shortening in LM environments (Hayes 1995: 223).

in order to realize all members of a consonant sequence within the CV(V)C template.

Orthographic /kw/ and /khw/ can be realized as labialized singletons—[k^w] and [k^{hw}]—in order to syllabify sequences of more than two word-medial consonants. Evidence that /khw/ can be parsed as the singleton [k^{hw}] is that this sequence patterns like the underlying labialized phoneme /k^w/.

- (16) [k^{hw} ~ k^h]
- | | | | |
|----|--|----|---|
| a. | o[k ^{hw}]a?
o-khw-a?
IT-food-NSF
'its food' | b. | ese:[k ^h]ó:ni?
e#s-e-khw-ɔni?
FUT-YOU.S-EPEN-food-make.ASP
'you will cook' |
|----|--|----|---|

As shown in (16a), the [w] in the /khw/ sequence is pronounced before non-rounded vowels, but deleted before rounded vowels. In this respect, the sequence /khw/ patterns like tautomorphic, labialized /k^w/ and unlike the heteromorphic sequence /k+w/.

Phonetic evidence that [y] can be realized as a secondary articulation is provided in §11.

7.1. Realization of /ts/, /ks/, /st/, and /sk/ as singletons

I propose that /s/ in stop-s and s-stop sequences can also be merged with other segments in order to meet syllable template requirements (following Dyck 1990; Steriade 1994: 248-249). The s-stop sequences /sk/ and /st/ can be realized as the singletons [s^t] and [s^k], while the stop-s sequences /ks/ and /ts/ can be realized as [k^s] and [t^s]. While the latter possibility is relatively uncontroversial, the realization of /st/ and /sk/ as singletons requires further motivation: first, there is evidence from English child language acquisition and from English phonotactic constraints in favour of analysing /sk/ and /st/ as singletons. For example, Barlow & Dinnsen (1998: 2) argue that clusters pattern like singleton affricates in one child's disordered phonology; they also discuss a wide range of evidence from previous studies supporting the claim that children represent clusters as single units underlyingly (ibid: 3-4); of particular interest is a study by Smit (1993), (cited in Barlow & Dinnsen 1998: 4-5), which reports epenthesis '...to be uncommon in normally developing children's productions for all target /s/ clusters of English.' This '...lend[s] support to the notion that (at least) the /s/ clusters are represented as single units underlyingly for [normally developing] children and perhaps even adult speakers of English.' (Barlow & Dinnsen 1998: 5).

Second, evidence from English phonotactics involves 3-consonant onsets, which all begin with [st], [sk], or [sp], followed by [l], [r], [y] or [w] (see discussion in Kerstowicz 1994: 258); these sequences violate the SSP and complicate the description of English syllable structure if the s+stop portions are construed to be sequences; however, if analysed as singletons, s-initial sequences are unexceptional.

In summary, evidence from English shows that /s/ + stop clusters can be analysed as singletons. Likewise, I hypothesize that all of the [+continuant], non-vocalic segments of Cayuga can be realized as secondary articulations, especially when there are more than two consonants in a sequence to be syllabified. With this assumption, it is possible to explain how most sequences are syllabified in Cayuga. However, before showing that this is the case, it is first necessary to deal with certain complications regarding the syllabification of the laryngeals.

8. SYLLABIFICATION OF LARYNGEALS

I will argue below that postvocalic laryngeals syllabify into the nucleus, rather than the coda of the syllable. Furthermore, when postvocalic, the laryngeals are realized either as full segments or as secondary articulations, depending on whether or not they are in a lengthening environment. In contrast, non-postvocalic laryngeals typically syllabify as full segments, unless they occur in larger clusters; in the latter case, they can undergo MERGE so that all segments of the sequence may be phonetically realized.

8.1. Postvocalic syllabification

The postvocalic syllabification of laryngeals is seemingly atypical: when postvocalic, /h/ and /ʔ/ syllabify with a **preceding** syllable rather than into the onset of a following syllable (Michelson 1988: 118; postvocalic laryngeals also syllabify with the preceding syllable in Mohawk and Onondaga; Michelson 1988: 64, 94-5.) Evidence for the atypical syllabification of postvocalic laryngeals in Cayuga is from LM: as shown in (17), LM applies even to (weak) syllables which are closed by a **single postvocalic laryngeal**. (Underlining of a vowel in the orthography denotes the application of LM; thus, the underline l /o/ has been devoiced in (17)—see footnote 1).

- (17) a. satkəh:ə́h áe
 s-at-kəhs-ohae
 YOU.S-3EM1-face-wash
 'wash your face!'
 b. [sat . kəh . sə́h . á . e]

In order to describe the environment for LM uniformly, one must assume that postvocalic laryngeals syllabify with a preceding syllable, as in (17b). It is then possible to say that LM is triggered by laryngeals occurring within the same syllable as the affected vowel. This reasoning leads to the conclusion that postvocalic laryngeals in Cayuga do not syllabify as onsets, violating a strong cross-linguistic trend.

However, the atypical postvocalic syllabification of laryngeals follows from the assumption that the laryngeals are less sonorous than low vowels, but more sonorous than high vowels and [w, y]:

(1') Sonority scale:

[low vowels > mid vowels, ʔ, h > high vowels, w, y > r > n > t, k, s]

Given the above assumption, postvocalic laryngeals do not syllabify as onsets because they are vowel-like enough to resist glide formation. In comparison, the other approximants [w, y], more readily syllabify into the syllable margin because they are less sonorous than /ʔ/ and /h/.

In summary, postvocalic laryngeals syllabify with the preceding syllable. A remaining question is whether postvocalic laryngeals syllabify into the nucleus or into the coda of the preceding syllable. To address this question, I review evidence from the phonetic realization of laryngeals (§6) and from the general retention of laryngeals word-finally (§4.4). First, the phonetic evidence is that postvocalic laryngeals are realized either as non-modal vowels or as secondary articulations of vowels; this observation indicates that the laryngeals are more vowel-like than other segments. Thus, the SSP predicts that vowel-like (laryngeal) segments should prefer a nuclear position. Second, laryngeals are retained word-finally while the other sonorants (/n/, [w], and [y]) are deleted. Laryngeal retention is unremarkable only if we assume that postvocalic laryngeals syllabify into the nucleus, rather than into the coda. With this assumption, it is possible to state that Cayuga generally prohibits sonorants in coda position. This prohibition affects /n/, [w], and [y], which would otherwise syllabify into the coda word-finally, but it has no effect on the word-final laryngeals, which can syllabify into the nucleus. To illustrate:

(18) a. /...ɛn + ʔ/

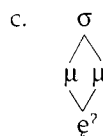
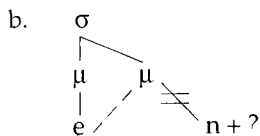

when the underlying sequence shown in (18a) is syllabified, the /n/ undergoes Stray Erasure, with CL (18b). The final glottal stop in (18c) is then realized as laryngealization on the final long vowel (i.e., it is syllabified into the nucleus).

While postvocalic laryngeals syllabify into the nucleus, non-postvocalic laryngeals syllabify into other positions, as outlined below.

8.2. Laryngeal syllabification word-initially and after consonants

/h/ appears word-initially, while /ʔ/ never occurs word-initially for morphophonemic reasons.¹³ (As the facts are similar for /h/ and /ʔ/, I will discuss only /h/ below.)¹⁴ /h/ is not stray-erased word-initially, and in this position, /h/ cannot be syllabified into a nucleus (since /h/ is never the sole occupant of the nucleus). I propose that /h/ syllabifies as a full-segment onset when it is word-initial. (19) gives the representation for the word-initial syllable [ha]. (Features are omitted for non-laryngeal segments.)

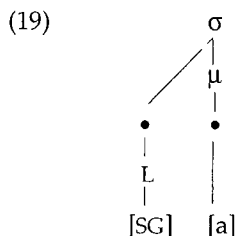

/h/ must also syllabify as a full-segment onset when it appears as the second consonant of a two-consonant sequence: this is because, as discussed in §5.2, any two-consonant sequence, including one ending with /h/, is heterosyllabic for the purposes of accent placement. (20) illustrates such two-consonant sequences in the string [at.ha]:

¹³ Non-phonemic [ʔ] is inserted word-initially before vowels (Michelson 1988:10).

¹⁴ The segment /ʔ/ normally occurs after vowels, and rarely occurs as the second member of a consonant cluster. (In the majority of cases where /ʔ/ does occur after a consonant, the /ʔ/ begins a diminutive suffix /-ʔah/.) Phonetically, a consonant cluster with /ʔ/ is pronounced as a glottalized consonant. I hypothesize that /ʔ/ is realized as the secondary articulation of a preceding consonant, and otherwise patterns like /h/.

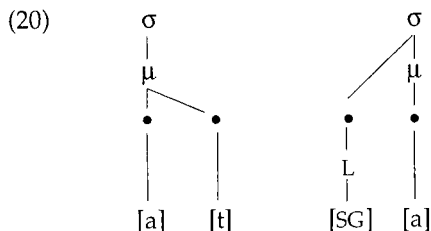

In summary, the laryngeals syllabify as full segments when they are: 1) postvocalic in lengthening environments (§6.1); 2) word-initial (§8.2); or 3) the second consonant of a two-consonant sequence (§8.2). In contrast, the laryngeals are realized as secondary articulations in non-lengthening environments (§6.2) and when in larger (3+) sequences (§6.3-6.4).

Having outlined how laryngeals syllabify, it is now possible to explain how consonant sequences syllabify in general. In the following sections, I outline how word-medial, word-final, then word-initial sequences are syllabified.

9. PARSING OF WORD-MEDIAL CONSONANT SEQUENCES

Word-medial two-consonant sequences (listed previously in (5)) syllabify as follows:

(21) a.	Nucleus	Onset	Nucleus	Onset
	h	t	h	k
	h	s	?	t
	?	k	?	s
	?	h		
b.	Coda	Onset	Coda	Onset
	n	y	n	r
	t	y	t	r
	t	k	t	s
	t	h	t	?
	k	y	k	r
	k	h	k	?
	s	y	s	w
	s	r	s	n
	s	h	s	?

If the first consonant of a sequence is laryngeal (21a), the laryngeal syllabifies into a nucleus and the second consonant syllabifies as an onset; otherwise, (21b), the first consonant syllabifies into a coda and the second, into an onset.

Larger word-medial sequences syllabify as follows. (Laryngeals which are parsed as secondary articulations are superscripted):

(22)	Nucleus	Coda	Onset	Nucleus	Coda	Onset
		t	sh		th	w
		th	y		th	r
		th	n		k	th
		k	sh		kh	n
	h	n	h	h	t	k
	h	t	h	h	k	r
	h	s	h	h	s	r
	h	s	th	h	s	?
	?	t	h	?	th	r
	?	k	h	?	s	h

Any initial laryngeal syllabifies into a nucleus; non-laryngeal consonants syllabify into either a coda or an onset; where necessary, nonpostvocalic laryngeals are merged as secondary articulations of onset/coda consonants in order to realize all members of the sequence within the CV(V)C syllable template.

Word-medial three- and four-consonant sequences such as /tkw/, /tkhw/, and /skw/ can also be realized as surface two-consonant sequences with labialization—[tk^w], [tk^{hw}], and [sk^w]. They syllabify into the CV(V)C template as follows:

(23)	Coda	Onset	Coda	Onset
	t	k ^w	t	k ^{hw}
	s	k ^w		

The initial consonant of any sequence syllabifies into a coda; the remaining sequences, /kw/ or /khw/, are realized as a singleton onset consonant.

The largest word-medial sequences contain both /h/ and /s/. They syllabify as follows:

(24)	Nucleus	Coda	Onset	Nucleus	Coda	Onset
	h	st	r	h	sk	r
		st	r			

Any initial laryngeal syllabifies into a nucleus, and /s/ merges with /t/ or /k/ to form a singleton, which is parsed into coda position. /r/ then syllabifies as an onset.

For reasons which will become apparent, larger word-medial sequences such as /tkt/ and /tkn/ will be reanalysed as word-initial. These sequences will be discussed in §11.

10. PARSING OF WORD-FINAL CONSONANT SEQUENCES

Word-final sequences beginning with laryngeals syllabify as follows:

(25)	Nucleus	Coda
	h	s
	h	t
	ʔ	s
	ʔ	t
	ʔ	k

Any initial laryngeal syllabifies into the nucleus of the final syllable; an obstruent /t/, /k/ or /s/ then syllabifies into the coda of the final syllable.

Other word-final sequences parse as follows:

(26)	Nucleus	Coda	Stray Erasure
		k	t
	h	s	t
		s	t
		s	k
		k	w
	h	k	
		t	w

Any initial laryngeal syllabifies into the nucleus; then, the first of two obstruents syllabifies into the coda of the final syllable; finally, the last segment of each sequence undergoes Stray Erasure. Although /kw/ and /tw/ could also be parsed as the singletons [k^w] and [t^w], I hypothesize that even if they did so, they would simplify to singletons lacking secondary articulations because of a general prohibition against complex segments word-finally.

10.1. Preference for parsing /s/ word-finally

In the word-final sequences /(t)s/, and /(k)s/, we expect final /s/ to delete; however, the /t/ and /k/ delete instead. Assuming MERGE, the word-final stop-s sequences /ks/ and /ts/ should be realized as the surface affricates [k^s] and [t^s]. However, Cayuga does not have any complex segments word-finally (although Mohawk and other related languages have final [ks] and [ts]). I propose that MERGE does apply to /(t)s/ and /(k)s/, but that the resulting affricates [k^s] and [t^s] subsequently simplify to fricatives word- (or syllable-) finally:

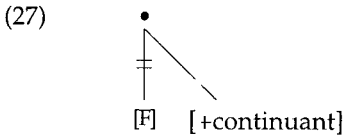

As shown in (28), word-final affricates undergo deletion of relevant place features ([F]); the feature [+continuant] remains and is ultimately realized as word-final [s]. Syllable-final simplification of affricates also occurs in languages such as Basque, where /ts/ becomes [s] in coda position if a plosive follows (Hualde 1987). A similar process occurs in Innu-aimun (Montagnais), where the affricate /tʃ/ becomes [s] before [t] (Clarke 1982: 18).

11. PARSING OF WORD-INITIAL CONSONANT SEQUENCES

Most word-initial sequences (see (4)) cannot be syllabified into the single-consonant cnsset proposed in §5.2: however, as discussed in §7, some underlying sequences can be parsed as singletons after MERGE has applied:

(28) Simplex onsets: [k^h], [s^h], [t^h], [n^h]

(I include /nh/ here, although, as discussed in §4.1, its status as a word-initial sequence is marginal.)

Other word-initial sequences that can parse as singletons are /tsh/ and /tsy/, which are pronounced respectively as [t^{sh}] and [j]/[t^s]. ([j] is in free variation with [t^s]; [j] more commonly occurs before front vowels, but [t^s] can also be heard in this position.) As in §7, I hypothesize that the second and third consonant of each sequence can be realized as secondary articulations of the initial coronal consonants; in other words, /tsh/ and /tsy/ can be realized as single segments or simplex onsets:

(29) More simplex onsets: [t^{sh}], [t^s]/[j]

11.1. A word-initial appendix

Some of the remaining word-initial sequences violate the SSP; I propose that such sequences syllabify via non-core syllabification, specifically into an Ap(pendix) to the prosodic word.

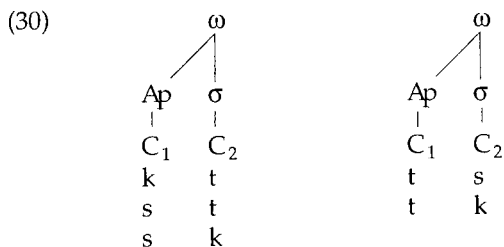

As shown above, given the appendix, it is possible to syllabify at most two consonants word-initially, (the first consonant into the appendix, and the second consonant into the onset of the first syllable of the word). In the environment shown in (30), /sk/, /st/, /ts/ and /ks/ are not parsed as singletons word-initially; this is because MERGE is a last resort.

Syllabification into the appendix also permits word-initial consonant sequences of rising sonority to be realized:

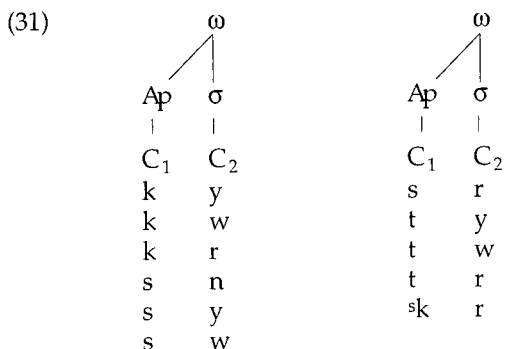

The first consonant of a two-consonant sequences syllabifies into the appendix, and the second consonant syllabifies into the onset of the first syllable. In the /skr/ sequence, /s/ merges with /k/ to form a singleton, [sk].

In summary, assuming a CV(V)C template, MERGE, and a word-initial appendix, it is possible to syllabify most of the consonant sequences of Cayuga. Sequences which remain to be explained are exceptionally large ones such as /tk/ and /tkn/. These remaining sequences are analysed below.

12. SYLLABIFICATION OF WORD-INTERNAL THREE-STOP SEQUENCES

Recall that word-internal consonant sequences such as /tk/ contain three stop segments. No mechanism posited so far can explain the exist-

The prosodic structure shown in (34) is incomplete because the initial syllable is not incorporated into a prosodic word. Interestingly, rethinking the prosodic structure of words such as (34) allows for a unified analysis of prothesis and of the existence of exceptionally large clusters. Below, I argue that the Cayuga verb is a prosodic phrase, rather than a prosodic word; as a consequence, anomalous word-medial clusters can be reanalysed as unexceptional word-initial clusters.

Evidence that the Cayuga verb is a prosodic phrase comes from the motivation for prothesis. First, prothesis does **not** take place in order to create an accentable foot: words with prothetic vowels are often still not accentable in isolation (for example, the word [itktaʔk] has no word-accent). Nor does prothesis take place in order to create a minimal word: Dyck (1997) argues that words such as /t-k-taʔk/ without a prothetic [i] already contain enough material for a foot/minimal word, viz. a heavy / closed syllable.¹⁵

To explain why prothesis occurs, I propose that the prothetic vowel in (34) forms not only a syllable, but a separate prosodic word:

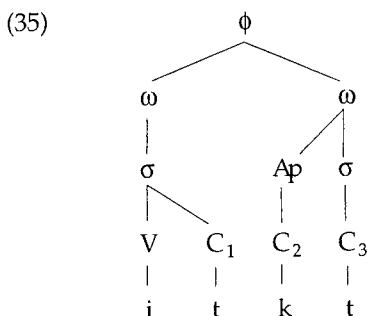

As illustrated in (35), the prosodic unit which corresponds to the morphological word [itktaʔk] is a prosodic phrase (ϕ) containing two prosodic words (ω). Assuming this, the motivation for prothesis is to create a minimal (two- ω) prosodic phrase: cross-linguistically, many languages have rules which adjust the size of the prosodic phrase so that it minimally contains two prosodic words (see discussion in Inkelas & Zec 1995: 544).

¹⁵ Words such as [itktaʔk] bear no High tone accent when pronounced in isolation. However, when utterance-medial, such words bear High tone on the final syllable. This final H tone is not word-accent, but rather, an intonational High tone. (Dyck 1997).

If verbs with prothetic vowels contain two prosodic words, then large sequences such as /tk̩t/ actually span a word boundary; as shown in (35), such sequences are unexceptional under this reanalysis.

The above proposal assumes a more complex internal structure for the Cayuga verb, which is further motivated below.

12.2. The Cayuga verb-word as a prosodic phrase

The assumption that the Cayuga verb is a prosodic phrase is consistent with the generative syntax insight that verbs in polysynthetic languages are 'Infl' Phrases (IPs; Chomsky 1991, Pollock 1989). Assuming that the Cayuga verb-word is a syntactic phrase, it should also be a prosodic phrase: this is because, following Selkirk (1986) and later work, syntactic phrases (such as IP) generally map into prosodic phrases (ϕ). Syntax-phonology mapping thus provides a prosodic structure (a ϕ -phrase) which triggers a minimal size requirement; the latter motivates prothesis. Prothesis, in turn, creates a prosodic word and allows for an appendix into which an extra consonant can be realized.

The structure posited in (35) not only explains sequences after prothetic vowels, but also sequences occurring at the major boundary which exists between the prepronominal prefixes and the pronominal prefixes. (Recall that this boundary has been marked with a # in all relevant examples.) Example sequences include /tk̩n/ and /sk̩n/:

- (36) a. ɛtk̩nɛ:ts̩i:ne?
 ɛ-t#k̩-nɛ:ts̩-hi:ne-?
 FUT-DUAL-I-arm-lead-PUNC
 'I will lead it by the arm'
- b. ɛts̩nik̩q̩hɛ?
 ɛ-t#s̩-ni:k̩q̩hɛ-?
 FUT-DUAL-2-YOU.S-depressed-PUNC
 'you will be depressed'

To explain such sequences, I propose that the prepronominal prefixes are separate prosodic words (or proclitics) and that the boundary between the prepronominal and pronominal prefixes is a word boundary. The prepronominal prefixes are a mixed group, including mood morphemes, morphemes expressing movement towards or away from an object, negation morphemes, etc. The prepronominal prefixes express concepts which are expressed through syntactic words (such as adverbs and modals) in other languages.

Assuming the proclitic analysis, the examples in (36) would parse as follows:

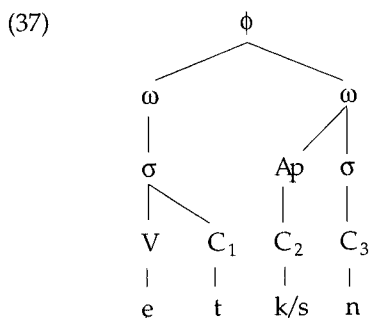

The initial /t/ of these three-consonant sequences would syllabify with the first prosodic word, while the final two segments of /tkn/ and /tsn/ would syllabify with the second prosodic word.

In summary, larger sequences occurring near the left edge of the Cayuga verb exist because of the presence of a prosodic word boundary within the word. Following Inkelas (1989), the structure of words such as (35) and (37) is



where X is a proclitic or prothetic vowel.

12.3. Anomalous near-word-final sequences

Not discussed earlier is the fact that larger anomalous consonant sequences also exist near the right edge of the Cayuga verb. Positing a more complex prosodic structure for the Cayuga verb-word also explains the existence of these clusters. Example words are provided in (39). ((39b) shows the same verb root as in (39a); the relevant sequences are also enclosed in square brackets.)

(39) Extra segments near the right edge of the word:

- a. tesahsikya[?ksk]ø: 'you are always stumbling, etc.'
 te-s-ahsik-ya?k-s-kø:
 DUAL-YOU.S-foot-cut/break-HAB-FACILITATIVE
- cf. b. kahstøtri:ya[?s] 'a hay-mower'
 ka-hstøtr-iy-a?k-s
 IT-hay-cut/break-HAB

As shown in (39), the addition of certain suffixes such as the **facilitative** /-kɔ:/ enables the retention of consonants which would otherwise be deleted through Stray Erasure word-finally: the /k/ of the word-final /ʔks/ sequence is realized in (39a) but not in (39b). These facts can both be explained by assuming that /-kɔ:/ is an enclitic (see Inkelas 1989: 105). As a separate prosodic word, the enclitic can also have an appendix which licences an extra segment. To illustrate, the final two syllables of (39a) are contrasted with the final syllable of (39b) (subsyllabic constituency is omitted):

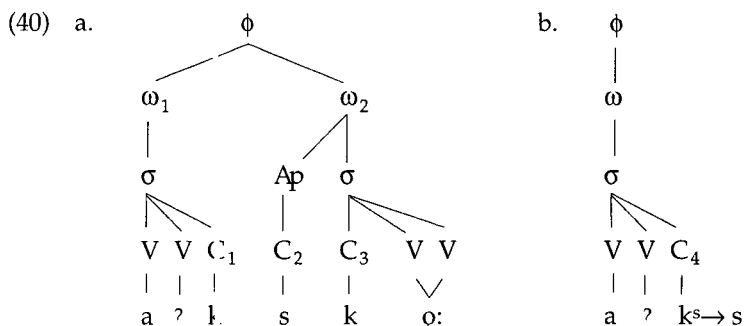

The presence of an appendix permits all of the segments of the sequence /ʔks/ to be syllabified in (40a):¹⁶ /k/ (C₁) appears in the coda of the first prosodic word (ω₁), while remaining consonants syllabify into the appendix (C₂) and onset (C₃) of the second prosodic word (ω₂). In contrast, the absence of an appendix in (40b) ultimately results in deletion of /k/ (C₄); /k/ is merged with /s/ to form the affricate [k^s]; subsequently, the features of [k] delete through syllable-final deaffrication (see §10.1).

In summary, larger sequences occurring near the right edge of the Cayuga verb exist because of the presence of an enclitic (prosodic word) boundary within the verb. Following Inkelas (1989), the structure of words such as (40a) is

$$(41) \quad [[\dots]_{\omega} X]_{\omega}$$

where X is an enclitic.

¹⁶ I assume that MERGE does not apply to the first /k/ and /s/ of the /ʔks#k.../ sequence; if it did, /ks/ would be realized as an affricate [k^s] and would then be subject to syllable-final deaffrication; thus the initial /k/ of the /ʔks#k.../ sequence would be deleted if MERGE had applied.

Positing the more complex prosodic structure for the Cayuga verb word explains the presence of all word-medial three-plosive sequences. Such larger sequences occur near verb edges, where they syllabify across proclitic / enclitic word boundaries.

13. SUMMARY: SYLLABIFICATION OF CAYUGACONSONANT SEQUENCES

I have shown above how to syllabify all Cayuga consonant sequences, assuming MERGE, a CV(V)C syllable template (abbreviated as CVC below), and a prosodically-complex verb-word:

(42)	$[[C_{AP} CVC]_{\omega}]_{\omega}$	$[C_{AP} CVC . CVC]_{\omega}$	$[C_{AP} CVC]_{\omega}]_{\phi}$
	\omega.i. \omega.f.	\omega.i. \omega.m. \omega.f.	\omega.i. \omega.f.
	\phi.i. \phi.m.	\phi.m. \phi.m. \phi.m.	\phi.m. \phi.f.
	A B	C D B	C E

First, as shown in (42), the left edge of the Cayuga verb is a word-initial and phrase-initial environment (A); a maximum of two stop consonants can be syllabified in this position, one into an Appendix, and one into an onset. Second, within the Cayuga verb, there are three environments: 1) a word-final, phrase-medial environment (B), 2) a word-initial, phrase-medial environment (C), and 3) a word-medial, phrase-medial environment (D). Three stop consonants can be syllabified across environments B and C. Third, the right edge of the Cayuga verb is a word-final, phrase-final environment (E). A maximum of one stop consonant can be syllabified into this position. Finally, continuant segments can be added to all the maximal stop clusters, provided that they are realized as secondary articulations.

14. A COMPARISON WITH PREVIOUS ACCOUNTS

Previous input-based accounts assume a larger template with complex onsets and/or codas. (See for example Benger 1984, 1985, Dyck 1990, and Doherty 1993 for Cayuga, Michelson 1983, 1988 for Mohawk). For example, perhaps the most well-developed account (Melinger 1997) initially posits the following template for Seneca:

- (43) Seneca syllable template
(initial version, modified from Melinger 1997: 25):

Onset				Nucleus	Coda	
{t,k}	{h}	{s,n,w}	{y,ʔ}	V	{ʔ}	{s,t,k,h}
1	2	3	4		5	6

However, Melinger notes that the above template grossly overgenerates consonant sequences for Seneca; '...for example, the template ... has six slots, but Seneca only allows a maximum of five consonants medially...' [Melinger 1997: 29]. Melinger is forced to posit a series of templates such as the following ones for three-consonant sequences:

(44) Seneca syllable templates for three-consonant sequences (partial list modified from [Melinger 1997: 37]):

- a. Onsets:
- | | | | |
|-----|-----------------|-----|---|
| i. | {t, s, h, k, n} | {y} | V |
| ii. | {ʔ, s, k, h} | | V |
- ...
- b. Codas
- | | | | |
|-----|---|-----|-----------|
| i. | V | {ʔ} | {t, s, k} |
| ii. | V | {h} | |

To syllabify Seneca three-consonant sequences, one first chooses the onset template which matches the prenuclear segment; for example, if the prenuclear segment is [y], then template (a. i) is used; template (a. i) allows one to syllabify first [y], and then a preceding [t], [s], [h], [k], or [n] into the onset. Next, mapping syllables from right to left, one chooses a coda template which matches any postnuclear segment not yet assigned to syllable structure.

While Melinger's approach is highly constrained, the constraints are essentially phonotactic or input-based.¹⁷ Problematically, as discussed in §1, the Optimality-Theoretic (OT) approach assumes that inputs are unconstrained.

However, I have shown in this paper that phonotactic constraints are not needed in order to account for the distribution of consonant sequences in Iroquoian languages. To illustrate, recall Cayuga word-medial, phrase medial consonant sequences repeated below (modified from (5)). (Postvocalic laryngeals which syllabify into the nucleus (either as full segments or as secondary articulations) are superscripted. Similarly, Merged secondary articulations are superscripted. Syllable boundaries are also shown.)

¹⁷ Melinger also provides an Optimality-Theoretic account of Seneca consonant sequences; however, the account posits language-particular phonotactic constraints in CON. For example, one such constraint is W-Co-occurrence: 'If **w** is the consonant that immediately precedes the vowel, then it cannot be preceded by **n** or **s**.' [Melinger 1997: 43].

(45) Word-medial, phrase-medial consonant sequences:

C2 → C1 ↓	y	w	r	n	t	k	s	h	?
n	n.y		n.r						
t	t.y		t.r			t.k t.k ^w t.k ^{hw}	t.s t ^s y t ^{sh}	t.h t ^h .w t ^h .y t ^h .r t ^h .n	t. [?]
k	k.y		k.r		k.t ^h		k.s ^h	k.h k ^h .n	k. [?]
s	s.y	s.w	s.r	s.n		s.k ^w	s.h		s. [?]
h				h.n h _n .h h _n .y	h.t h _t .k h.t ^h h.t ^{hw}	h.k h _k .w h _k .r h _k ^h .w	h.s h _s .h h _s .r h _s .t ^h h _s . [?]		
?					?t ?t.h ?t ^h .r	?k ?k.h ?k.sk	?s ?s.h	?h	

As shown in (45), the extant inputs are all **syllabifiable** into a CV(V)C template: two-consonant sequences are unremarkable and the 3+ consonant sequences all contain continuant segments which can be realized as secondary articulations in a 2-stop sequence.

The constraints which produce only the outputs in (45) would also filter out any putative sequences of three stops in word-medial, phrase medial position (henceforth D). For example, an output such as *[tkt] (from underlying /tkt/) in position D would always be ruled out as non-optimal because one consonant would be unsyllabified within the CV(V)C template. Position D inputs such as /tkt/ would always be subject to epenthesis, surfacing as the output [tVkt] or as [tkVt].¹⁸ Consequently, a non-alternating output such as [tVkt] would have to be reanalysed as the input /tVkt/ because of the Alternation Condition (Kiparsky 1968).

In summary, input-based constraints on what consonants can occur in a sequence are not necessary: the extant input sequences are all syllabifiable into a CV(V)C template; that is, the extant sequences represent an optimal lexicon, one in which the inputs are those with the most harmonic outputs

¹⁸ Alternatively, one could argue for a deletion account of putative tautomorphic 3-stop sequences. The resulting non-alternating position D output would argue the same point.

[Itô, Mester & Padgett 1995: 28], or one in which large position D input sequences must contain continuant segments.

Another advantage of the present account is that it explains the existence of anomalous 3-stop sequences **which exist only in verbs**: in polysynthetic languages, verbs (but not nouns) are syntactic/prosodic phrases and can contain several syntactic/prosodic words. The very existence of word-boundaries (and word-appendices) within the verb complex allows for the retention of extra-large consonant sequences.

In conclusion, Cayuga has a CV(V)C template; nevertheless, because of underparsing (MEFGE) and a prosodically-complex verb, some sequences of 3 stops are retained in the language.

REFERENCES

- BARLOW, JESSICA A. & DANIEL A. DINNSEN. 1998. Asymmetrical cluster development in a disordered system. *Language Acquisition* 7,1: 1-49.
- BENGER, JANET. 1984. *The Metrical Phonology of Cayuga*. Unpublished MA thesis, University of Toronto.
1985. *Accent and Vowel Length in Cayuga*. Paper read at the Symposium on Canadian Native Languages in Theoretical Perspective. Buffalo, N.Y.
- BOOJ, GEERT & JERZY RUBACK. 1987. Postcyclic versus postlexical rules in lexical phonology. *Linguistic Inquiry* 18: 1-44.
- CHAFE, WALLACE. 1977. Accent and related phenomena in the Five Nations Iroquois languages. In Larry M. Hyman (ed.), *Studies in Stress and Accent: Southern California Occasional Papers in Linguistics no. 4*. Los Angeles: Department of Linguistics, University of Southern California, 169-81.
- CHAFE, WALLACE & MICHAEL K. FOSTER. 1981. Prehistoric divergences and recontacts between Cayuga, Seneca, and the other Northern Iroquoian languages. *International Journal of American Linguistics* 47: 121-142.
- CHOMSKY, NOAM. 1991. Some notes on economy of derivation and representation. In R. Freidin (ed.), *Principles and Parameters in Comparative Grammar*. Cambridge, Mass.: MIT Press.
- CHOMSKY, NOAM & MORRIS HALLE. 1968. *The Sound Pattern of English*. New York: Harper and Row.

- CLARKE, SANDRA. 1982. *North-West River (Sheshātshīt) Montagnais: a Grammatial Sketch*. Canadian Ethnology Service, Mercury Series Paper 8. Ottawa: National Museum of Man.
- CLEMENTS, GEORGE N. 1990. The role of the sonority cycle in core syllabification. In John Kingston & Mary E. Beckman (eds.), *Papers in Laboratory Phonology I: Between the Grammar and the Physics of Speech*. Cambridge: Cambridge University Press, 283-333.
- CLEMENTS, GEORGE N. & ELIZABETH HUME. 1995. The internal organization of speech sounds. In John Goldsmith (ed.), *The Handbook of Phonological Theory*. Cambridge: Blackwell Publishers, 245-306.
- DOHERTY, BRIAN. 1993. *The Acoustic-phonetic Correlates of Cayuga Word-accent*. Unpublished PhD dissertation, Harvard University.
- DYCK, CARRIE. 1990. *Cayuga Syllable Structure and Epenthesis*. Unpublished MA thesis, University of Toronto.
1997. Accent and lengthening in Cayuga (Iroquoian). *Canadian Journal of Linguistics* 42, 3: 285-322.
- FOSTER, MICHAEL. 1974. *From the Earth to beyond the Sky: An Ethnographic Approach to four Longhouse Iroquois Speech Events*. Paper 20. The Mercury Series. Ottawa: Ethnology Division, National Museum of Man.
1982. Alternating weak and strong syllables in Cayuga words. *International Journal of American Linguistics* 48, 1: 59-72.
- HAYES, BRUCE. 1995. *Metrical Accent Theory. Principles and Case Studies*. Chicago: University of Chicago Press.
- HOOVER, JOAN BYBEE. 1974. *Aspects of Natural Generative Phonology*. Bloomington, Indiana: Indiana University Linguistics Club.
- HUALDE, JOSÉ. 1987. On Basque affricates. *Proceedings of the West Coast Conference on Formal Linguistics*. Stanford, California: Stanford Linguistics Association, Stanford University, 6: 77-89.
- INKELAS, SHARON. 1989. *Prosodic Constituency in the Lexicon*. Unpublished PhD dissertation, Stanford University.
- INKELAS, SHARON & DRAGA ZEC. 1995. Syntax-phonology interface. In John Goldsmith (ed.), *The Handbook of Phonological Theory*. Cambridge: Blackwell Publishers, 535-549.

- ITÔ, JUNKO, ARMIN MESTER & JAYE PADGETT. 1995. Licensing and underspecification in Optimality Theory. *Linguistic Inquiry* 26: 571-613. (ROA-38)
- KENSTOWICZ, MICHAEL. 1994. *Phonology in Generative Grammar*. Cambridge: Blackwell Publishers.
- KIPARSKY, PAUL. 1968. (1974). How abstract is phonology? Reprinted in O. Fujimura (ed.), *Three Dimensions of Linguistic Theory*. Tokyo: TEC Co. Ltd, 1-136.
- LAVER, JOHN. 1994. *Principles of Phonetics*. Cambridge: Cambridge University Press.
- LOUNSBURY, FLOYD. 1963. Linguistics and psychology. In S. Koch (ed.), *Psychology: a Study of a Science*. New York: McGraw-Hill, 552-582.
- MALMBERG, BERTIL. 1963. *Phonetics*. New York: Dover Publications.
- MCCARTHY, JOHN & ALAN PRINCE. 1986. *Prosodic Morphology*. Ms, University of Massachusetts and Brandeis University.
- MELINGER, ALISSA. 1997. *Syllabification, Foot Structure and Accent in Seneca*. Unpublished MA thesis, S.U.N.Y. at Buffalo.
- MICHELSON, KARIN. 1983. *A Comparative Study of Accent in the Five Nations Iroquoian Languages*. PhD dissertation, Harvard University.
- MICHELSON, KARIN. 1988. *A Comparative Study of Lake-Iroquoian Accent*. Studies in Natural Language and Linguistic Theory. Boston: Kluwer Academic Publishers.
- MITHUN, MARIANNE & REG HENRY. 1982. *Waṭewayéstanih: A Cayuga Teaching Grammar*. Brantford, Ontario: Woodland Cultural Educational Centre.
- POLLOCK, JEAN-YVES. 1989. Verb movement, Universal Grammar, and the structure of IF. *Linguistic Inquiry* 20: 365-424.
- POSTAL, PAUL. 1969. Mohawk vowel doubling. *International Journal of American Linguistics* 35: 291-98.
- PRINCE, ALAN & PAUL SMOLENSKY. 1993. *Optimality Theory: Constraint Interaction in Generative Grammar*. Ms., Rutgers University, New Brunswick and University of Colorado, Boulder. (Forthcoming MIT Press.)

SELKIRK, ELIZABETH. 1978. On prosodic structure and its relationship to syntactic structure. In T. Fretheim (ed.), *Nordic Prosody vol. 2*. Trondheim: TAPIR, 111-140.

1986. On derived domains in sentence phonology. *Phonology* 3: 371-405.

SMIT, ANN BOSMA 1993. Phonologic error distributions in the Iowa-Nebraska Articulation Norms Project: word-initial consonant clusters. *Journal of Speech and Hearing Research* 36: 931-947.

SMOLENSKY, PAUL 1995. *On the internal structure of the constraint component CON of UG*. Handout for a talk given at UCLA, April 7, 1995.

STERIADE, DONCA. 1994. Complex onsets as single segments. In Cole, J. & C. Kisseberth (eds.), *Perspectives in Phonology*. Stanford University: CSLI, 203-291.