

# A NEW PORTABLE INSTRUMENT FOR MEASURING ANGLES (I)

by

Dr. C. PULFRICH OF JENA

(Extract of a description given by the Inventor  
in the *Zeitschrift für Instrumentenkunde*, 1919, 39, 201-212).

The apparatus is based on the use of two reflecting prisms  $P_1$  and  $P_2$ , arranged one behind the other (Fig. 1 and 2). Fig. 1 shows the arrangement of the prisms in plane and Fig. 2 shows them in side elevation.  $P_1$  is a single rectangular prism with a reflecting surface  $S_1$ .  $P_2$  is a double prism formed by two single prisms and it has a surface  $S_2$  which form a double mirror. The prism  $P_1$  is fixed on the apparatus; prism  $P_2$ , the graduated circle  $T$  and the axis  $A$ , which is perpendicular to the plane of the mirrors, may all three be moved together for rough or accurate setting.

If the two reflecting surfaces  $S_1$  and  $S_2$  are set parallel to each other the rays, in passing through the prisms do not undergo any change in direction. All objects then appear *straight and in the same position and direction as when they are viewed directly outside the prisms*.

If the prism  $P_2$  is turned from its zero position towards the left or the right, the image of the landscape is also displaced laterally but in the *opposite direction* to which the prism is turned; the angular change being *twice* that of the prism. In order that objects may be viewed through the prisms and to one side of them simultaneously, a prism  $P_3$  is placed in between the eye and prism  $P_1$ ; it is composed of two parts covered with a semi-transparent layer of silver,  $S_3$ . This prism gives a double line

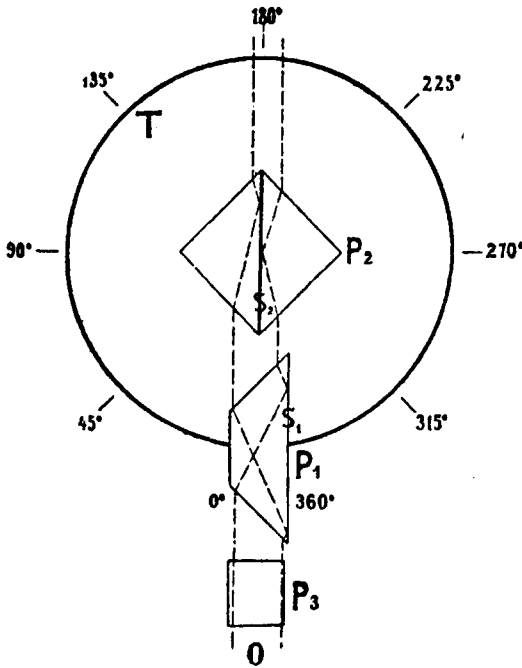

Fig. 1.

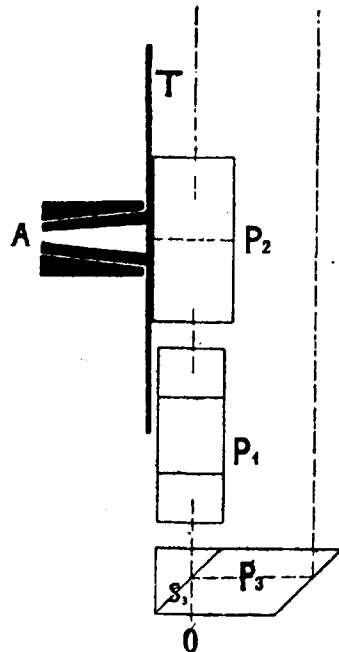

Fig. 2.

(1) The price of the apparatus is 650 R. M. from CARL ZEISS, Jena.

of sight : through the prisms  $P_1$  and  $P_2$  and above them (1). The observer is thus able to observe with accuracy the coincidence of the images of a point with itself or of two different points. *The difference in direction of the rays from two different points can be measured by the angle through which the prism  $P_2$  is rotated.*

It may be asked why, in this instrument, reflecting prisms have been used rather than ordinary mirrors. It is because the *prismatic mirror* (which is a more suitable term than reflecting prism), when employed as a sighting instrument, is far superior to the plane mirror, for the greatest effective aperture of the latter, *i.e.* the full area of the mirror, is towards the rear, or in the direction in which the observer gets in his own way. It is for this reason that the plane mirror is mainly used as a looking glass. If the mirror be turned to one side, the sighting aperture is reduced and, in the direction of the reflecting surface itself, it becomes nil.

In the prismatic mirror also, the direction towards the rear is excluded as a direction of the line of sight, thus this is taken as a *zero direction of the circle* which is divided into  $360^\circ$  and numbered from this zero *towards the right* (see Fig. 1).

If the angle which a plane mirror makes with the line of sight be known, it is easy to calculate the *width* of the sighting aperture for that mirror.

If, as has been done in Fig. 3, the magnitudes corresponding to the sighting aperture be laid off from  $M$  as radius vector, in the different directions of the line of sight, and if their terminal points be joined by a continuous line, the curve drawn in

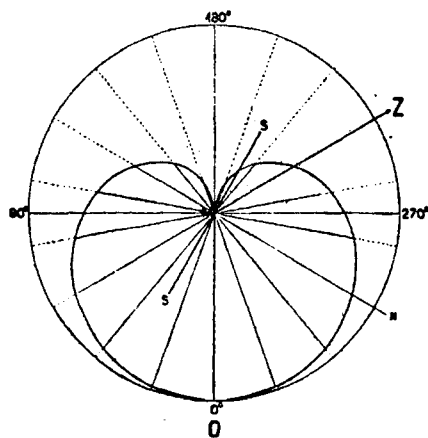

Fig. 3.

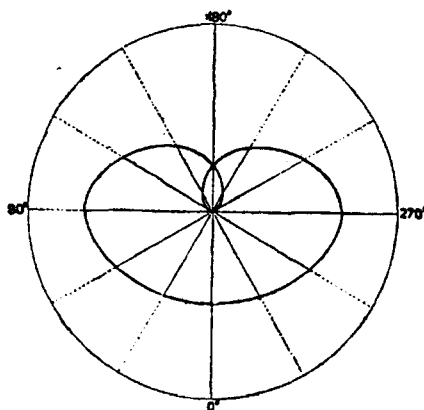

Fig. 4.

Fig. 3 is obtained. The position of the mirror  $S$ , corresponding to a determined radius vector on the curve, is obtained by dropping a perpendicular from  $M$  onto the bisector of the angle  $OMZ$ .

The curve in question becomes entirely different when the plane mirror is replaced by a *prismatic mirror* (Fig. 4). It will be seen immediately that, in the direction at right angles to the direct line of sight ( $90^\circ$  and  $270^\circ$ ), the width of the sighting aperture is just as large as in the case of a plane mirror, in fact equal to 0.7 of the size of the mirror. For other directions, the size of the effective aperture can be calculated in accordance with the laws of refraction.

Let it be assumed that the refractive index  $n$  of the glass is known as well as the magnitude of the angle of incidence  $i$  at which the rays fall on one or the other face of the right angle of the prism. If  $n$  be assumed to be = 1.57 and the angles  $\alpha_1$  and  $\alpha_2$  adjacent to the reflecting face of the prism to be =  $45^\circ$ , the value of the width of the sighting aperture in the straight ahead direction ( $180^\circ$ ) is 0.25, *i. e.* one quarter of the length of the mirror. Towards the rear ( $0^\circ$ ) twice this value is obtained, or, in other words, half the length of the mirror.

(1) In the new portable instruments for measuring the angles an arrangement has been adopted which permits the prism  $P_3$  with a semi-transparent silvered surface to be exchanged for another in which the silvered surface covers only half of the upper part of the field of vision. The method of making the measurement remains the same in both cases.

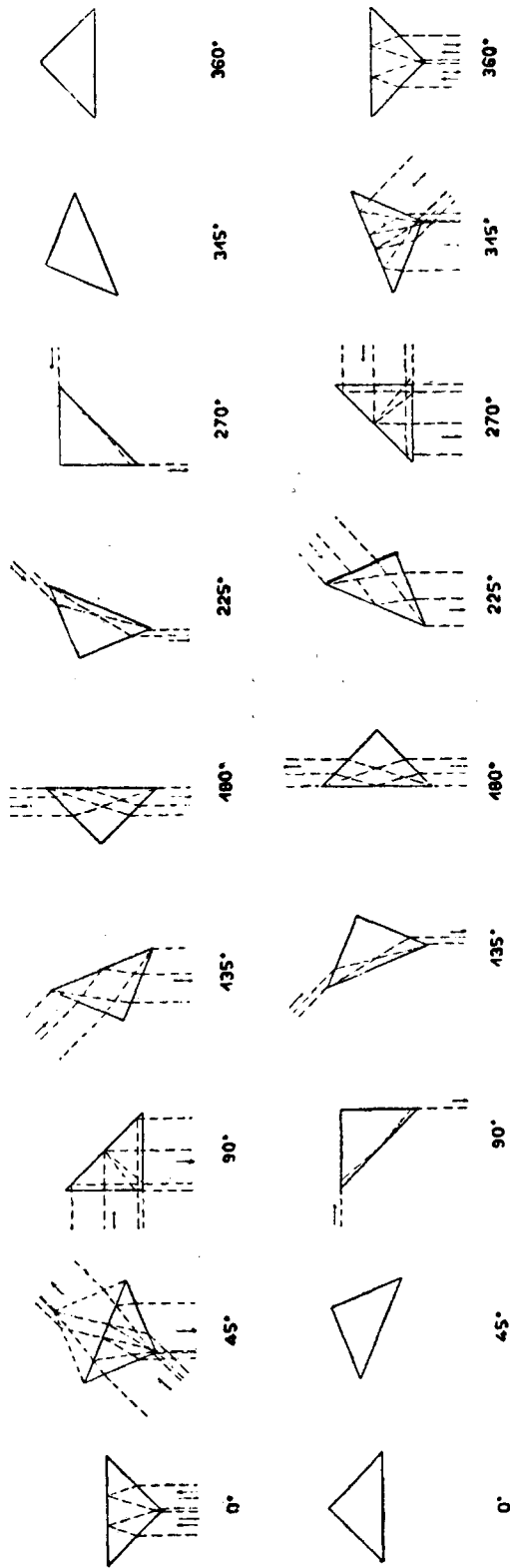

FIG. 5. — Path of the rays in the single prism. The prism makes a complete turn.

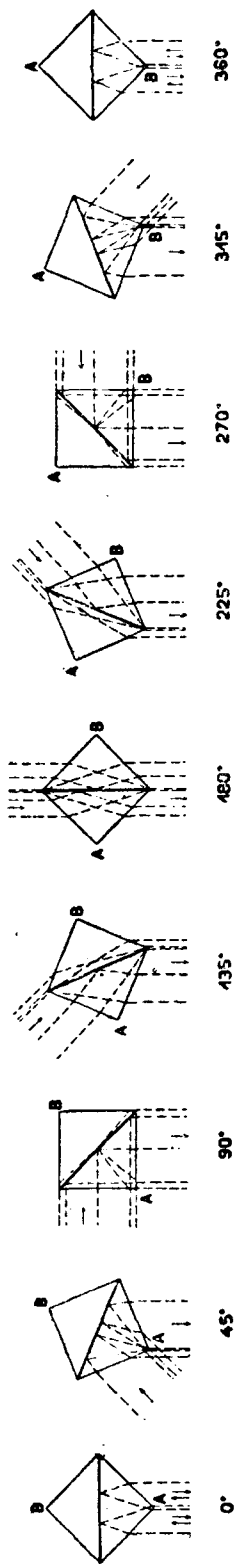

FIG. 6. — Path of the rays in the double mirror. The prism makes a half turn only.

The prismatic mirror does not act solely in the direction of the reflecting face, as though it were a plane mirror of infinite length, but continues to act when the reflecting face is turned away from the observer. The extreme limit of action of the prismatic mirror is reached when the incident rays just graze one of the faces of the right angle of the prism, and, after reflecting from the hypotenuse face, pass out again, grazing the other face of the right angle. In this limiting case the width of the pencil of rays is therefore equal to zero.

For further details on this subject, the *path of the rays*, as drawn in Fig. 5 for a series of positions of the prismatic mirror should be studied. It will be seen that by rotation of the prismatic mirror from its normal position ( $0^\circ$ ), the width of the pencil of rays emerging from the prism increases from 0.5 to 0.7 and decreases from this value to zero; it remains at this value for a series of positions and then increases again to 0.7 and gradually falls until finally, at the normal position, it returns to its initial value of 0.5.

The most striking feature in this is the fact that, for every sighting direction between  $90^\circ$  and  $270^\circ$ , there are two positions of the prismatic mirror differing from each other by  $180^\circ$  and in which the sighting aperture is not only of a different width — with the exception of the aperture at  $180^\circ$  — but is differently located also. *Therefore, with the single rotating mirror, the object aimed at is but incompletely attained*

All the drawbacks which are encountered here may, however, be eliminated at once by employing two prismatic mirrors united to form a double prism  $P_2$  (Fig. 1). As shown by the path of the rays indicated in Fig. 6, *the sighting aperture of the double prism is now of nearly uniform width in all directions, and is located in approximately the same position with respect to the centre of rotation*; for the magnitude, as shown by comparison with Fig. 5, is now equal to the *sum* of the two sighting apertures of each single prism in positions differing from each other by  $180^\circ$ . To the extent to which the action of one of the prisms is deficient, or is lacking, the other prism comes into play to supplement it. The loop in Fig. 4 disappears and Fig. 7 indicates the radius vectors, which, it is true, do not attain the magnitude of those of the plane mirror in any

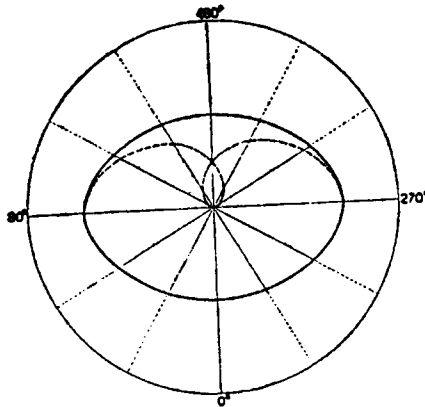

Fig. 7.

direction but which, on the other hand, are of nearly the same magnitude in the straight ahead and the sideways directions.

Another advantage of the double prism over the single prism is that, for the complete circle, it is not necessary to turn the double prism through more than half a turn. In fact rotation of the double prism to right or left is limited by *fixed stops* at  $45^\circ$  and  $315^\circ$ . Further, the directions of the line of sight at  $90^\circ$  and  $270^\circ$  are indicated by small *buttons* on the outside of the case. *All these marks are for the purpose of giving the observer who is roughly setting the graduated circle, some tangible indication of the side towards which the prism is directed.*

The optical effect of the double prism for incident parallel rays is the same as for a single prism. The image is always single, even when a portion of the rays has passed through one of the prism and the rest through the other prism; or when (see Fig. 6 and 7) one part of the rays falls upon one face of the right angle of a prism and the rest on the other face of the right angle. Double images only occur in the case

of objects very close together which, however, are never included in the measurements.

It is but necessary that the two faces of the prisms *fit together exactly and that they be parallel to each other, this is easy to obtain by careful adjustment.* Besides, the prisms should be free from so-called pyramidal errors.

It is evident that each of these prisms should satisfy the condition that the luminous ray falling on one of the faces of the right angle at an angle  $i_1$  (see Fig. 8) should leave the other face of the right angle at the same angle,  $i_2 = i_1$ . Generally the two angles  $\alpha_1$  and  $\alpha_2$ , adjacent to the reflecting face of the prism, are made equal to  $45^\circ$  although this is not absolutely essential. But it is necessary that the two angles  $\alpha_1$  and  $\alpha_2$ , should be *equal to each other.* Because, in this case only, the refraction and dispersion produced on entering the prism will be annulled by the contrary refraction and dispersion on emergence of the rays, and this prism acts as a plate with parallel faces, regardless of the change in direction of the pencil of rays (see Fig. 8).

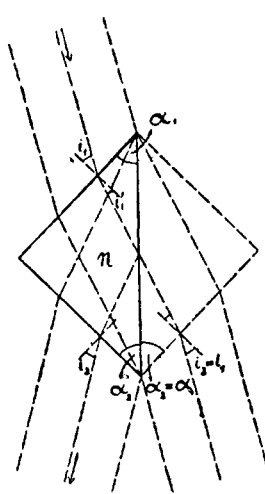

Fig. 8.

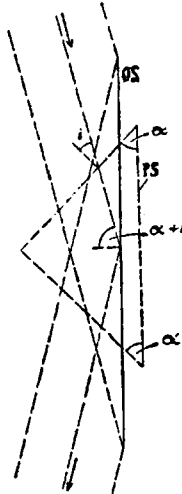

Fig. 9.

There remains nothing but the action of the hypotenuse face ; here the action is the same as it would be if the prism (see Fig. 9) were replaced by a *plane mirror* lying in the direction of the hypotenuse face on which the rays are incident at an angle of  $i + \alpha$  ; the length of this mirror would vary according to the position of the prism.

In the double prism, this latitude as to the magnitude of the angle  $\alpha$  always exists and, therefore, it is not necessary that the angles should agree in the two prisms, provided that, in each, the condition that  $\alpha_1 = \alpha_2$  is fulfilled.

In the arrangement so far described in the portable instrument for measuring angles, the zone of free visibility above the prisms  $P_1$  and  $P_2$  ( $180^\circ$ ) is at the centre of the field of measurement from  $45^\circ$  to  $315^\circ$  (see Fig. 10). *Consequently angular distances greater than  $135^\circ$  cannot be measured except indirectly by using an intermediate point.*

In order to measure angles greater than  $135^\circ$  without using an intermediate point, the following arrangement has been adopted. In the upper part of the path of the rays a pentagonal prism is inserted which deflects the rays  $90^\circ$ , as a part of the apparatus, in order to convert the direct line of sight to a lateral line at  $90^\circ$  therefrom. The field of measurement of the double prism remains the same, but it is differently divided (see Fig. 11) on both sides of the zero position : *i. e.* from  $45^\circ$  to  $90^\circ$  and from  $90^\circ$  to  $315^\circ$ . This is *amply sufficient* ( $315^\circ - 90^\circ = 225^\circ$ ) to permit the measurement of angles greater than  $135^\circ$  without the use of an intermediate point, for, when the angle to be measured is greater than  $180^\circ$ , it is possible to measure the reverse angle which is evidently less than  $180^\circ$ .

The graduated arc is numbered in such a manner that the direction of the line of sight through the double prism may be read off directly.

Readings of the graduated circle are taken by means of a small microscope, in the focal plane of which there is a scale for estimation. Readings may be taken to the nearest minute.

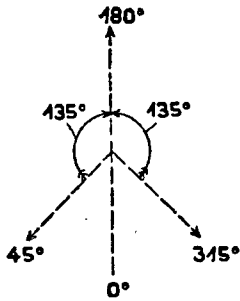

Fig. 10.

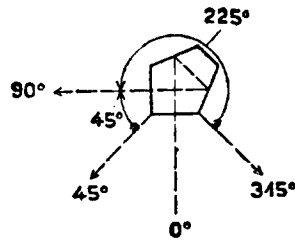

Fig. 11.

The apparatus is held by the *handle* which is screwed into the base of the instrument case for measuring horizontal angles, and into the side of the case for measuring vertical angles.

The handle itself is bored conically to enable it to be set up on a *plumb line pole* or a light tripod. The instrument may then be placed exactly over any given point from which measurements are to be made.

