

DESCRIPTION OF A MAREGRAPH FOR OBSERVATIONS IN THE OPEN SEA.

by

PROFESSOR WAS. W. SHOULEJKIN, Moscow.

(Extract from an Article published in the *Journal du Conseil Permanent International pour l'Exploration de la Mer* - Vol. IV, N° 2 - Copenhagen - August 1929).

Professor Was. W. SHOULEJKIN has designed a new type of maregraph. It was constructed at the workshops of the Moscow Institute of Physics and Biophysics for the Polar Expedition of the Maritime Scientific Institute. The second model of the instrument was constructed for the Hydrophysical Department of the Institute of Physics mentioned above.

We shall be able to judge of its efficiency only when sufficient material with regard to its working has been furnished by the expedition. But its construction is so simple that there can be no doubt as to its usefulness.

The most characteristic feature of this new type of maregraph lies in the fact that it does not respond to the absolute hydrostatic pressure at the depth at which it is placed, but registers only the changes of hydrostatic pressure caused by the tidal wave.

Before the apparatus is immersed it is not necessary to know the depth of the bottom at the given position; it is only desirable to know the limiting depth at which the measurements will be undertaken.

Professor SHOULEJKIN's first model was made to suit a depth of 300 metres, the aim of its construction being work in the Barents Sea. But there is no difficulty whatever in constructing a maregraph suitable for working at any given depth. Only its size needs slight alteration.

It is very important to note that this alteration concerns only the simplest part of the apparatus. The most important part of the instrument, that is its recording part, remains unchanged and is standard for any depth.

The accompanying figures give a series of detailed sections explaining the working of the instrument.

The recording mechanism is contained in the cylindrical box situated at the upper part of the instrument.

The recorder represents an ordinary pocket altimeter (Barographe Altimétrique de Poche. Système J. RICHARD) with only one alteration. This alteration concerns its aneroid box (2) which has an additional tube (3) soldered to an aperture in its side. Through this aperture the box is filled with air and afterwards the spring so regulated as to make the pen assume a position just in the middle of the paper roll when in normal conditions.

No other details of chamber (1) have been given in the figure in order to make the design as clear and distinct as possible.

The tube (3) opens at its other end into a vertical canal (11) which is connected with the inner space of the bell (15) by means of a very narrow canal (9) that is bored through the top of the cone and the disc (9) above it.

But besides this canal (3) another very narrow canal (4) with a valve (8) opens into the vertical canal (11). When this valve (8) is open, it establishes connection with the space (15) under the bell and the chamber (1) in which the recorder is fixed. Therefore, the external pressure on the sensitive box is equal to the internal pressure.

The opening and closing of the valve (8) is effected automatically by means of the rod (12). In the process of lowering, the maregraph is suspended on a ring fastened at the position (12); the spring (13) becomes compressed by the weight of the instrument itself, then the rod is raised and the valve (8) opens and remains open during the whole process of lowering.

Under the influence of the hydrostatic pressure the air under the bell (15) becomes more and more compressed. The external and internal pressures on the walls of the chamber (1) remain equally balanced. The internal pressure in all the other parts of the instrument is always equal to the external pressure and therefore one has nothing to fear in regard to the watertight condition of different covers and joints.

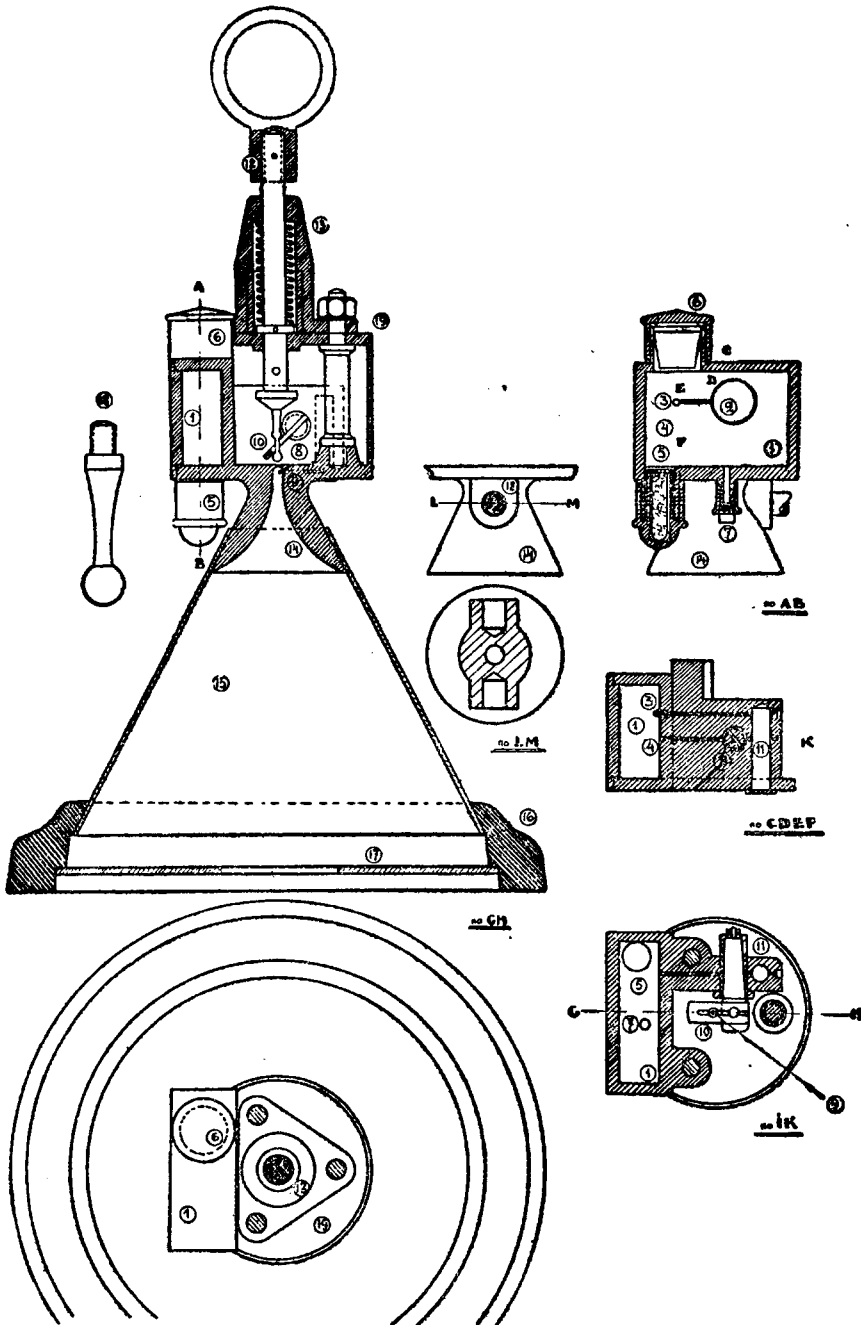

Now let us see what happens when the maregraph reaches the bottom of the sea. The very moment it touches the bottom, the spring (13) will cause the rod (12) to rise, which will result in the closing of the valve (8). From this very instant the membrane of the recording cham-

ber (2) begins to answer to the variations of the outside hydrostatic pressure caused by the tide.

While working with an expedition it will be necessary to leave the instrument lying at the bottom for a period not less than 24 hours. That enables a mechanism to be used which will make a full revolution in either 12 or 24 hours. In the first case the paper can pass twice under the pen. This will not confuse the record, for a tidal period lasts more than 12 hours.

At the end of the above-mentioned period the boat has to approach the buoy to which is fastened the rope holding the maregraph. The very moment the bell detaches itself from the bottom, the spring (13) is compressed by the weight of the instrument, the valve (8) opens and connection between the chamber (1) and the outside is established. Therefore all the time the maregraph is being hauled up the decrease in hydrostatic pressure will not affect it, as the air under the bell will expand and in due time expel the water from it.

The sensitivity of the instrument depends chiefly on the box (2) which has to be chosen according to the amplitude of the tidal waves likely to be experienced. The above described model is suitable for recording waves with amplitudes attaining 3.3 metres. The altimeter used was designed for a limiting height of 2,500 m. above sea level.

To prevent the access of water to all its different and delicate parts (such as covers and junctions of the different parts of the mechanism), one must always bear in mind the limiting change in pressure which can be endured. To make it as safe as possible the front cover of the chamber (1) is screwed down and soldered with fusible brass.

To prepare the maregraph for lowering, one has to carry out the following simple operations:—

- 1) Unscrew the covers 5-6-7.
- 2) Push aside the clips on which the paper is fastened (for this purpose there is a special handle under them).
- 3) Through the aperture (6) extract the old paper roll and put on a new one.
- 4) Introduce ink into the pen through (6).
- 5) Wind up the mechanism of the recorder through (7).
- 6) Change the calcium-chloride inside the glass capsule placed in the cover (5) (this capsule serves to dry the air inside the chamber (1) containing the clock mechanism).

After these operations all the covers of the instrument are to be tightly screwed up (to make them watertight all should have leather washers on them). In a later model an effort will be made to diminish the number of covers mentioned above.

As may easily be seen the handling of this instrument does not require special care or knowledge. The size is not unduly large. The first model prepared for investigations at a depth of 300 m. has a bell only 32 $\frac{1}{m}$ high. To construct a maregraph for a depth of 3,000 metres, it would be necessary to make the bell (15) 34 $\frac{1}{m}$ higher. The top of the bell holding all the vital parts of the mechanism would remain the same.

