

# METEOROLOGY AS AN AID TO NAVIGATION

by

COMMANDER L. G. GARBETT, R. N. (Ret.),

*Superintendent, Naval Division, Meteorological Office (London).*

---

## FOREWORD.

For some years after steam had superseded sail as a means of propulsion of vessels the need for studying meteorological conditions at sea seemed to have diminished, but with the advent of Wireless Telegraphy, by means of which reports of weather conditions over extended areas were enabled to be broadcast, and the construction of daily synoptic charts thus made possible, navigators are provided with the means of avoiding heavy weather and thus of increasing their safety and shortening their time of passage between ports. This is specially the case as regards Air Navigation in which comparatively new art the knowledge of meteorological conditions may be said to constitute an essential factor, but as it is almost equally important for the navigation of surface vessels the Directing Committee hopes to contribute towards the closer study of Meteorology by Seamen by publishing articles on the subject in the *Hydrographic Review*. Articles briefly touching on the subject have previously appeared in the publications of the Bureau but more technical ones are now considered necessary and Commander GARBETT, R. N., of the British Air Ministry, therefore kindly consented to prepare the one which appears in the present Review, and which it is hoped will lead to the receipt and publication of others from those readers who have made a particular study of the subject.



Meteorology is the science of the atmosphere or in other words the study of the weather; Marine Meteorology primarily deals with that portion of the atmosphere which lies over the great masses of ocean but it includes also the study of ocean currents which have a considerable effect on climate and weather.

The weather has been so bound up with the daily life of the sailor ever since ships went to sea that he has inevitably become something of a weather prophet. His constant watch on the barometer, the movement and types of cloud and the general appearance of the sky, together with the development of that weather sense which comes from long experience of all weathers, renders the sailor particularly well able to draw conclusions as to the probable changes of the weather in the particular locality in which he happens to be situated. In the days of sailing ships seamen of stern necessity had to become proficient in weather forecasting, the propelling power of ships being dependent entirely on the weather. With the introduction of steam in the middle of the nineteenth century the weather ceased to be the all-important factor controlling the movement of ships and the seamen's interest in the weather elements might naturally have been expected to diminish. With the

increase in size and speed of ships, the increasing emphasis placed upon accuracy in navigation and the development of competition in trade, which renders it more and more necessary to make quick passages, the weather, however, has again become a factor of importance to all seamen. Furthermore, although the sea to-day may take smaller toll of large steamers than it did of sailing ships, which even at their biggest were very small by comparison with present day ships, recent disasters at sea remind us that even to well-found ships, with powerful engines, wind and sea can still be dangerous.

Meteorology has proved itself, in fact, to be an essential branch of modern seamanship, and the valuable results, both in safety in navigation and economy in operation, accruing from a knowledge of the subject are every day being more fully recognised; accurate forecasts may prevent a whole fleet raising steam to carry out exercises which would have to be abandoned later on account of bad weather, will enable the hydrographical surveyor to adjust his programme to fit in with weather conditions and may facilitate the making of a safe and rapid passage by a merchant ship.

It is only appropriate that a science with the development of which sailors have always been closely associated should still be able to give them valuable aid in return, and it is particularly satisfactory to realise that the valuable contributions to meteorology made by the old seamen of past centuries, prominent amongst whom were DAMPIER, BEAUFORT and MAURY, are still being utilised, if only indirectly, by their present-day successors. William DAMPIER (1652-1715), sailor and buccaneer, was a pioneer in the collection of information regarding the distribution of the winds over the oceans. His "Discourse on Winds" was a publication of very much value to those interested in Marine Meteorology and a similar publication on tides and currents is a remarkable one for the time in which it was written and shows his great knowledge of the subject. Francis BEAUFORT (1774-1857), Rear Admiral and Hydrographer of the British Navy, is known to all seamen and meteorologists as the author of the BEAUFORT Scale of Wind Force (1) and the BEAUFORT Notation for Weather. The BEAUFORT Scale and Notation are now in general use by Meteorological Services (they were adopted by Great Britain in 1838) and have been used by seamen for nearly a century. BEAUFORT was a keen meteorologist and from the year 1790 onwards kept a meteorological log. The first mention of the BEAUFORT Scale and Notation is found in his log of 1806; the facsimile of the page facing January 13 in the log is produced as Fig. 1. Anyone comparing the scale and notation used to-day with the original scale and notation will find that very few changes have been made. The third of these fathers of marine meteorology was Matthew MAURY (1806-1873), American Naval Officer and Hydrographer. MAURY may rightly be described as the founder of scientific Marine Meteorology. He induced shipmasters of the Merchant Navies all over the world to co-operate with him in collecting observations of winds and currents which were recorded in specially prepared

---

(1) See *Quarterly Journal R. Met. Soc.*, Vol. 51, No 218, April 1926: Admiral Sir Francis BEAUFORT and the BEAUFORT Scale of Wind and Weather, by Commander L. G. GARBETT, R.N., and Special Publication No 11 (April 1926) with Table 22 b (December 1931) of the International Hydrographic Bureau.

Hereafter I shall estimate the force of the wind according to the following scale, as nothing can convey a more uncertain idea of wind and weather than the old expressions of moderate and cloudy &c &c

0	Calm	7	Gentle steady gale
1	Faint air just at calm	8	Moderate gale
2	Light air	9	Brisk gale
3	Light breeze	10	Fresh gale
4	Gentle breeze	11	Hard gale
5	Moderate breeze	12	Hard gale with heavy gusts
6	Fresh breeze	13	Storm

And the weather as follows &c

b	Blue sky	h	Hazy
f	Fair weather	dp	Damp air
d	Dry warm atmosphere	fg	Foggy
s	Salty	r	Rain
p	Piping clouds.	sr	Small rain
c	Clear, i.e. that is clear hard horizon but not blue sky.	dr	Drizzling rain
cl	Cloudy	hr	Hard rain
w	Wazy sky	sh	Showers
wd	Wild, forked, confused threatning clouds	hsh	Hard showers
dk	Dark heavy atmosphere	sa	Slight weather
l	Light air	sy	Heavy breeze
t	Thunder	sq	Squally
g	Gloom, dark weather	hsq	Hard squally
gr	Gray, threatening appearance	bk	Black horizon & cloudy
		thr	Threatning appearance

FIG. 1

Fac-simile of the page of Beaufort's log (in possession of Royal Meteorological Society of London) showing original scale of wind force and original Beaufort notation for weather.

log books. In the course of nine years he collected enough information to give the equivalent of 50,000 days observations. The result of his work was to show the necessity for the co-operation of the maritime nations in Marine Meteorology and his efforts led to the convening of an International Conference in Brussels in 1853. The work of this Conference was of considerable benefit to both navigation and meteorology and out of it has grown the pre-

sent International Meteorological Organisation. This organisation now consists of (1) the Conference of Directors, (2) the International Meteorological Committee, (3) the Commissions on various branches of meteorology. The Conference of Directors discusses administrative questions and the methods of putting into practice recommendations made by the International Meteorological Committee. The International Meteorological Committee is the executive body and considers all questions relating to the development of the science including the recommendations submitted to it by the Commissions. These commissions are appointed to discuss in detail the international organisation of Marine Meteorology, Weather Telegraphy etc. Through the International Meteorological Organisation co-operation in meteorological work is furthered and any question of international interest relating to the subject should be referred to this body.

Since MAURY commenced the collection of meteorological information from the sea areas the collection has never ceased and on the observations so made our knowledge of the general circulation of the atmosphere and the distribution of pressure and temperature in all parts of the world is mainly based. The object of the laborious process of obtaining data is to determine the average conditions at all times of the year so that the sailor may know the type of weather he is most likely to meet at any particular time.

Marine Meteorological Atlases are now prepared by the sea-faring nations of the world and are a valuable aid to navigation. Unfortunately there is no uniformity in the production of these atlases and the methods of showing direction and force of the winds and the other elements vary to some extent. Great Britain prefers the BAILLIE Wind Rose (Fig. 2), which gives percentage

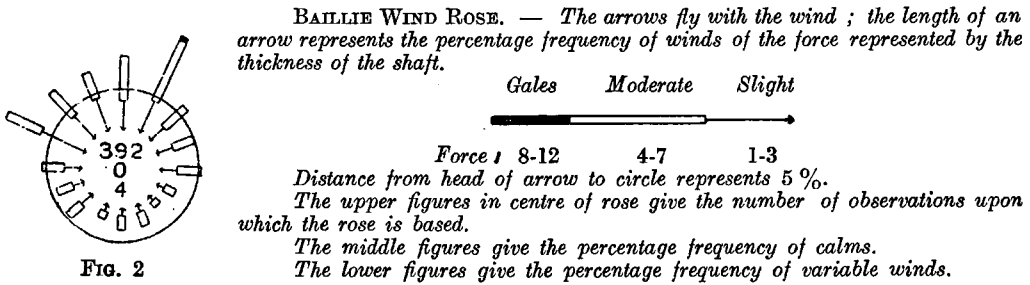


FIG. 2

frequencies of light, moderate and stormy winds, as being the best method of depicting winds, whereas France, Germany, Japan and U.S.A. show on their charts the percentage frequency and mean force for the several directions of the wind, the former by the length of an arrow and the latter by the number of feathers (Fig. 3).

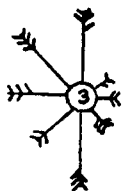


FIG. 3.

*The arrows fly with the wind.*

*The length of an arrow measured from the centre of the circle on the scale gives the percentage frequency of winds from that direction ; the number of feathers indicates the average force, on the Beaufort scale, of the winds from that direction.*

*The figure in the centre of the circle gives the percentage of calms, light air and variable winds.*

A new wind rose which is an adaptation of the BAILLIE Wind Rose has recently been proposed by Sir Napier SHAW and Commander L. G. GARBETT, R.N. (1). They consider that a disability of the usual methods of representing wind is the difficulty of showing with twelve separate wind roses seasonal changes in the wind, if there be any, and they have designed one rose in which data for all twelve months can be given. This new rose consists of a column for each month built up on the sides of an octagon or a 16-sided polygon each side of which represents a direction of the wind. (Figs. 4 and 5

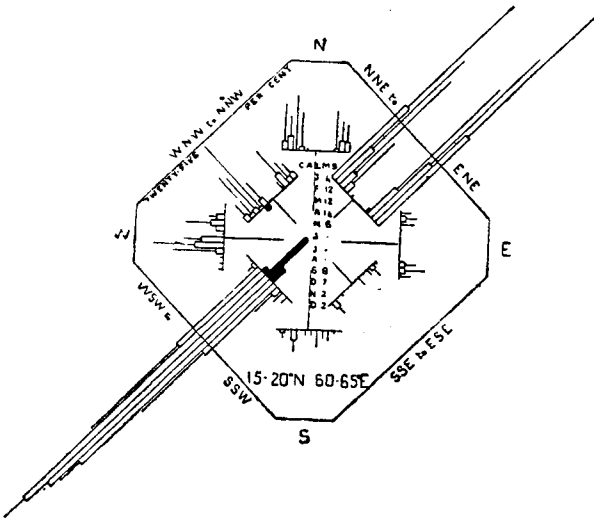


FIG. 4

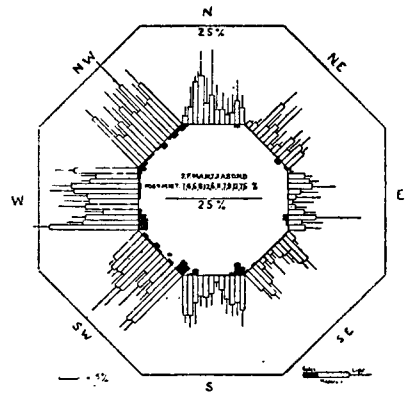


FIG. 5

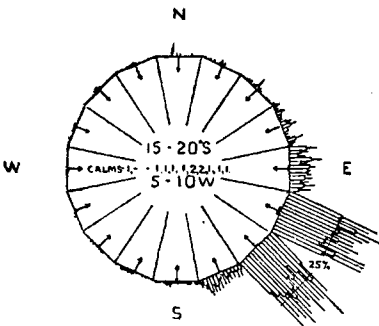


FIG. 6

show different types of 8-point wind roses and Fig. 6 a 16-point wind rose). The rose can be interpreted easily, the gales stand out with striking prominence within the polygon and the direction of the prevailing winds and their seasonal changes can be seen at a glance.

There is a similar lack of uniformity in the methods of depicting currents. In the Marine Observer, the publication of the Marine Division of the British Meteorological Office, current data are given in the form of a rose (Fig. 7).

(1) See *Quarterly Journal*, Royal Meteorological Society, Vol. LIX, No 248, January 1933.

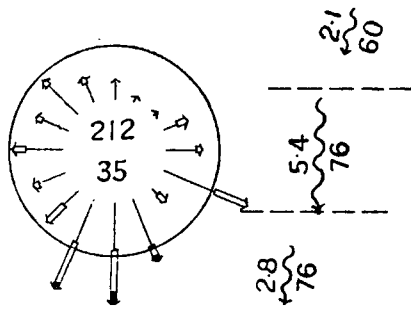


FIG. 7

In the representation of resultant drifts the wavy arrow is centered along the mean track. The figures above the arrow give drift in miles per day; the figures below give number of observations upon which resultant drift is based.

FIG. 7.

EXPLANATION OF CURRENT ROSE. — Arrows flow with the current; length of arrow represents percentage frequency of drifts of magnitude indicated by thickness of shaft. The magnitudes are indicated as follows:

6-12	miles per day	→
13-24	» » »	⇒
25 and over	» » »	⇨

Distance from tail of arrow to circle represents 5%.  
 Upper figures in centre of rose give number of observations upon which rose is based.  
 Lower figures give frequency of currents less than 6 miles per day.

Many of the current charts in existence to-day require revision and the importance of continuing the collection of current data is emphasised. For the last ten years the Marine Division of the British Meteorological Office has been busily engaged in the re-charting of currents and this important work is being continued. Modern developments in the art of navigation have made it possible to obtain the ship's position with great accuracy, with a corresponding increase in accuracy of the calculated set and drift of the current and the data now being collected and included in the revised current charts will therefore be appreciably more reliable than that contained in the older charts.

A new though incomplete atlas of the currents of the North Atlantic was published in 1930, this being the first of a series which is to include all oceans, and many variations from the old current charts are shown. A survey of the currents experienced on the routes across the Pacific has been made and a great deal of entirely new information obtained. An investigation of the currents of the Indian Ocean is throwing new light upon the subject of ocean currents (1), for the movements of the surface waters in this ocean are greatly affected by the Monsoons. An outstanding fact established in this investigation is that the current circulation which is generally counter-clockwise off the shores of the Arabian Sea and Bay of Bengal during the height of the N.E. monsoon changes generally to clockwise during February, when the N.E. monsoon still blows and before the advent of the S.W. monsoon. Now the charting of the Agulhas, Mozambique and East African coast currents has been completed and it is apparent how these currents are affected by the prevailing winds. The chief cause of ocean currents appears to be the direct friction of the wind upon the surface of the sea, although forces due to the rotation of the earth, differences of temperature and specific gravity, and atmospheric pressure also play their parts to a greater or lesser degree in maintaining the currents. The set and drift of the currents are of such importance to the navigators of ships in all parts of the world that the re-charting of the currents of all oceans demands international co-operation and it is to be hoped that some international scheme will eventually be forthcoming.

(1) Information in this connection appears in the *Marine Observer* (The Review of the Marine Division of the British Meteorological Office).

In addition to wind and current charts the British Marine Meteorological Atlases contain charts of sea and air temperatures and pressure and also tracks of revolving storms, a knowledge of which is of the greatest importance to those navigating in tropical seas. It was not until the beginning of the 19th century that men began to consider whether tropical storms might not be subject to some sort of law, their attention being drawn to the subject by the terrible havoc caused by the hurricanes of both the East and West Indies. The American, W. C. REDFIELD, and Colonel REID of the Royal Engineers (G. B.), who had had experience with West Indian hurricanes, set themselves in 1830 the task of collecting data from which to plot the development and tracks of these storms and Captain Henry PIDDINGTON, a British seaman, followed with work on similar lines. The labours of these men were beneficial in the extreme for they revealed that outside the tropics all the seemingly irregular winds obey what is essentially the same law as that which determines the direction of the wind and the course of the storm in hurricanes. This Law of Storms holds to-day as it did more than a century ago and is well known by all seamen. When the Law of Storms was first enunciated seamen were very reluctant to take any note of it, often with disastrous consequences. The experience of a brig, the *Chas. Heddle*, served, however, to bring home the value of the law to those who still doubted. The *Chas. Heddle*, being overtaken by a hurricane, put the helm up and ran before the wind so that she was carried eventually right round the centre, always in the same violent wind. At the end of her first circuit she was slightly nearer the centre than she had been at the beginning owing to the now well known fact that the wind blows slightly towards the centre. She continued to run dead before the wind going round and round the centre in great danger all the time and suffering much damage. In the course of 3 days she ran 3 times round the centre and then providentially the storm left her. Now, in addition to the law of storms, we have BUYS BALLOT'S Law to make the understanding of these tropical storms still clearer. This law enunciated by Professor BUYS BALLOT of Utrecht in 1857 has been a great aid to seamen as well as a valuable contribution to meteorology. From the law the seaman knows that if he faces the wind the centre of the storm is eight to twelve points on his right; having thus ascertained the position of the centre the prudent navigator, in whatever type of ship he may be, heaves to, discovers for himself whether he is in the path of the storm or in which semicircle the ship lies, and acts accordingly. Reports are often received of the disastrous consequences of these storms, no doubt partly due to the fact that some navigators have the idea because they are in large and powerful ships they can ignore them; the damage sustained and losses incurred to ships passing through these storms however prove that no ships, no matter how seaworthy, can afford to try conclusions with them.

The data in the meteorological atlases described above are based upon observations taken by ships and this work is still being continued by observing ships all over the world. The fundamental meteorological observations required and usually taken are as follows:

1. Weather and state of sky.
2. Temperature and humidity of the air and temperature of the sea surface.
3. Pressure or height of the barometer.
4. Wind direction and force.
5. Horizontal visibility.

In addition to the above there are innumerable opportunities at sea for the observation of optical phenomena. Such phenomena are often closely connected with the weather and should be carefully noted as they often give useful information about prevailing conditions. Observations of 1 and 5, and usually of 4, are eye observations but for the remainder instruments are required. Most ships are equipped with a mercurial barometer, aneroid and wet and dry bulb thermometers and these need only be briefly remarked on; other instruments such as the thermograph, hygrograph, psychrometer, barograph and wind velocity recorder, which are used in some ships, but with which seamen generally are not so familiar, require to be described in more detail. These latter instruments are of the greatest value if a real study of the weather is to be made and the best results obtained.

No special skill is required in obtaining the observations referred to above and every seaman is familiar with the recording of such observations in the ship's log book. In cases where a special meteorological log is kept particular care should be taken to obtain accurate observations bearing in mind that the observations will not only be used in connection with the construction of meteorological atlases, but are of immediate value to the ship's officer with meteorological knowledge in forecasting the weather. These observations will now be discussed individually.

### 1. *WEATHER AND STATE OF SKY.*

As stated in the early part of this article the BEAUFORT Notation is used for recording the state of the weather; in this notation, all the usual weather phenomena, rain, hail, snow, thunder etc. can be recorded with brevity and precision — the forms, amount, and direction and velocity of travel of clouds should also be recorded. Cloud forms are classified in three main groups according to the heights at which they occur; they are spoken of as high, medium and low clouds. The low clouds are subdivided into stratus and cumulus and various combinations of these. The medium clouds are alto-stratus and alto-cumulus. The high clouds are the cirrus types, cirrus, cirro-stratus and cirro-cumulus. Photographs of these types are included in most meteorological text-books and a very comprehensive International Cloud Atlas has recently been published by the French Meteorological Service.

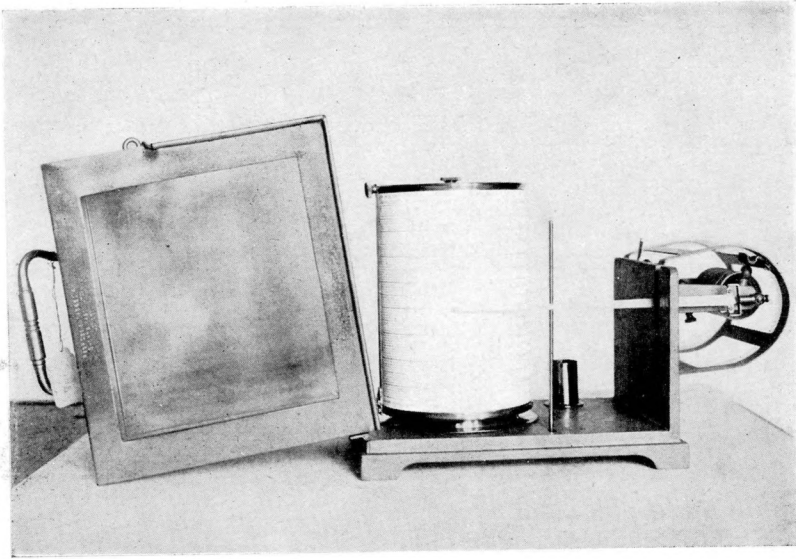
### 2. *TEMPERATURE AND HUMIDITY.*

The thermometers used for measuring meteorological work are graduated either on the Fahrenheit or the Centigrade scales. In Great Britain and U.S.A. the Fahrenheit scale is used but in other countries the Centigrade scale is adopted. Thermometers used for meteorological work should have been properly tested by some central institute before issue; in Great Britain this tes-



ting is done at the National Physical Laboratory. The ordinary wet and dry bulb thermometers are fitted in a portable louvered screen which should be placed in a well-exposed position not affected by artificial sources of heat; the best exposure is usually found on the weather side of the bridge. Great care must be taken to keep the dry bulb free from moisture and the wet bulb moist by means of a covering of fine muslin to which is attached a piece of cotton wick whose lower end dips into a small vessel containing *fresh* water. Special muslin caps incorporating muslin and wick are supplied by the British Meteorological Office. The muslin and wick should be frequently washed in fresh water to remove the salt which accumulates and should be changed every three weeks. The difference in temperature shown by the dry and the wet bulbs is due to the loss of heat caused by the evaporation from the wet muslin. The evaporation is more rapid as the dryness of the air increases and therefore the difference between the two readings furnishes a measure of the humidity of the air; the relative humidity may be obtained by referring to the humidity tables provided. In order to give accurate results the readings should be estimated to the nearest fifth of a degree.

It is often of great assistance in forecasting to have a continuous record of the temperature and for this purpose a self-recording thermometer known as a thermograph is used. In the ordinary thermograph (Fig. 8) a bi-metallic strip is used to measure the temperature. The unequal expansion of the two metals causes the strip (which is wound in a coil) to bend or unbend and this operates a pen arm whose movement is proportional to the temperature change causing it. The movement is recorded on a chart graduated with a temperature scale. This instrument can be exposed on deck in a louvered screen similar to that used for ordinary thermometers or hoisted on the foremast. A distant reading thermograph (Fig. 9) is also available which is more suitable for use in ships. This consists of a steel bulb filled with mercury which is housed in a screen at the top of the foremast and connected to the recording mechanism in the chart house or some similar position by means of armoured capillary tubing. The action of the distant reading instrument depends on the variation of pressure due to the change in temperature of the mercury in the bulb; this variation of pressure operates the pen arm. By having two coils and two pens on the bi-metallic thermograph or two bulbs joined to separate pens on the distant reading thermograph, a record of wet bulb temperature as well as dry bulb can be obtained. A record of relative humidity can also be obtained from the hair hygograph (Fig. 10). In this instrument the variations in length of a bundle of human hairs, which are caused by variations in relative humidity, operate the pen arm, through a cam mechanism. The method of obtaining temperature and humidity from wet and dry bulb thermometers in a screen has not been found to be entirely satisfactory owing to the difficulty of always ensuring adequate ventilation of the screen. In view of the importance of accurate observations of these elements experiments have been made from time to time to perfect a more suitable instrument and several types of such instruments known as psychrometers have been developed. The most satisfactory type is the ASSMANN aspiration psychrometer (Fig. 11) which consists of a wet and a dry bulb thermometers placed side by side in



*Bimetallic Thermograph.*

FIG. 8

*Thermomètre enregistreur bi-métallique*

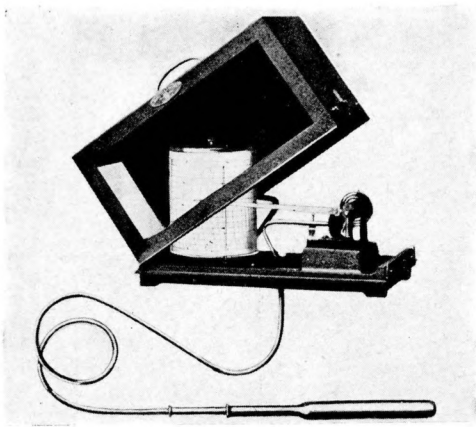


FIG. 9

*Distant Reading Thermograph*  
*Thermomètre enregistreur à lecture à distance*

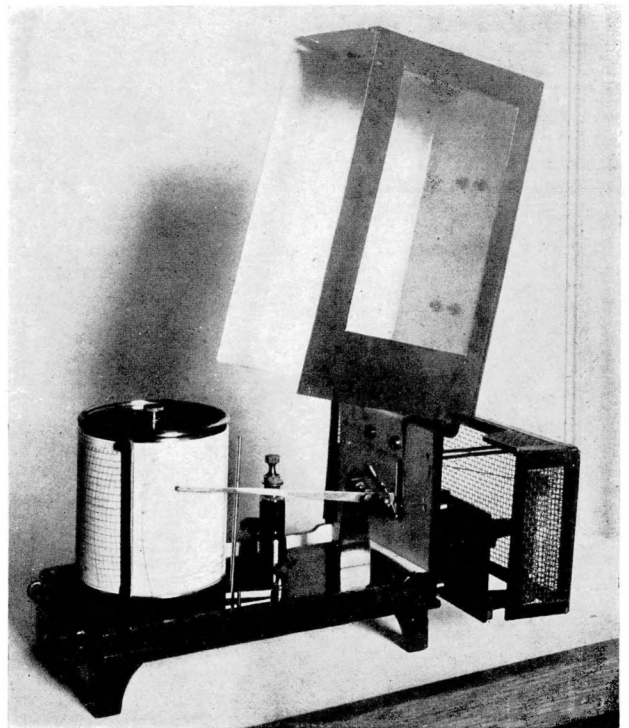


FIG. 10

*Hair Hygrometer.* *Hygromètre enregistreur à cheveu*

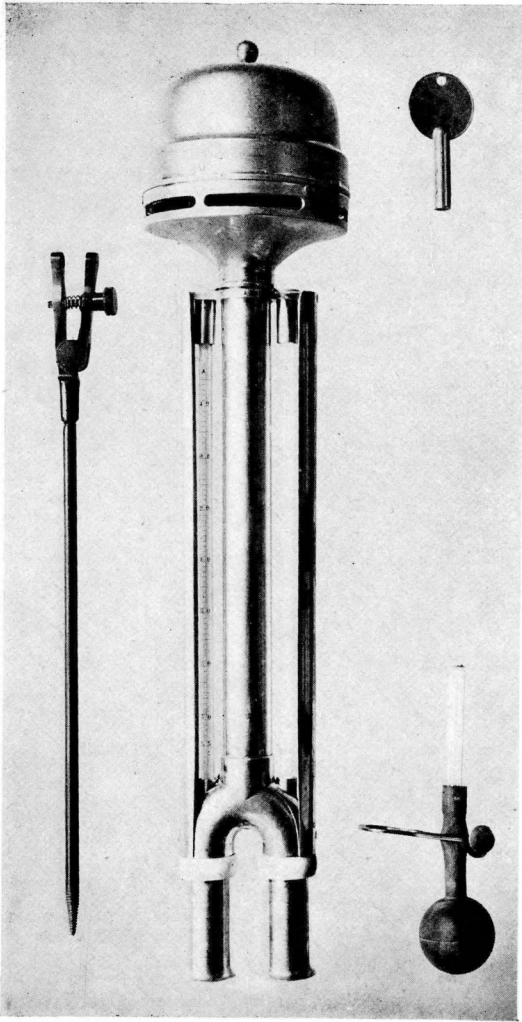


FIG. 11  
*Assmann Psychrometer. Psychromètre d'Assmann*

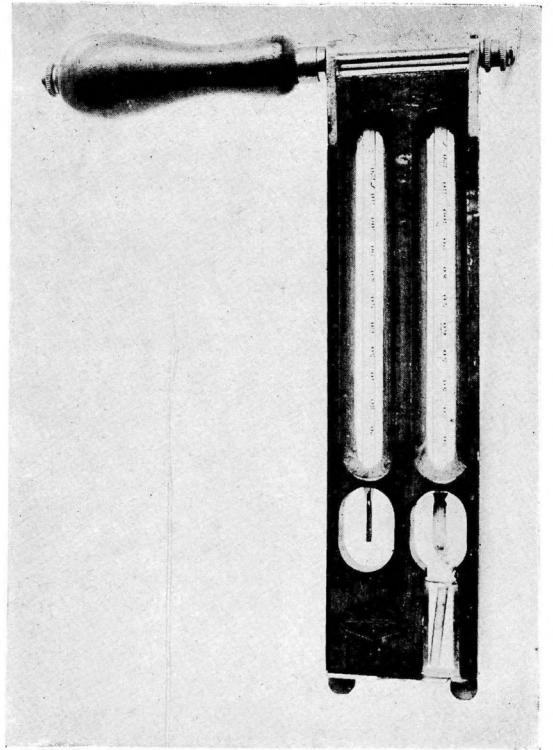
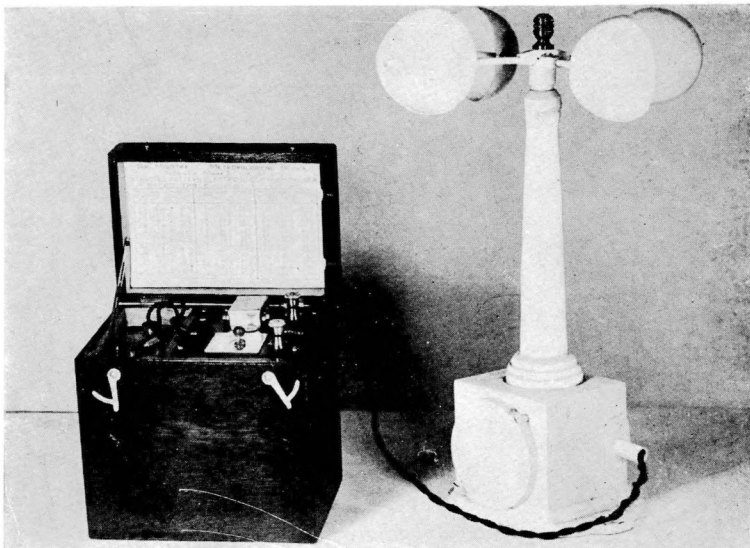


FIG. 12  
*Whirling or Sling Psychrometer.  
 Psychromètre à fouet ou à fronde*



*Electric Cup Anemometer.*

FIG. 14  
*Anémomètre électrique à coupelles*

metal tubes over which air is drawn at a constant rate by a quick-running fan actuated by clockwork or an electric motor.

The whirling or sling psychrometer (Fig. 12) is another type which is used by the U.S. Service; it is very simple in construction consisting of a wet and a dry bulb mounted side by side on a wooden frame, which is provided with a spindle and handle so that the thermometer bulbs can be whirled in the air. Although this ensures adequate ventilation, the instrument presents difficulties in reading as the thermometer bulbs have to be unprotected and therefore tend to heat up from the observer's body when being read. The ASSMANN aspiration psychrometer is the most satisfactory instrument. All psychrometers should be used on the windward side of the ship, as near the side as possible.

For the sea surface temperatures an ordinary thermometer fitted with a sea thermometer protector is used. The water to be used for taking the sea surface temperature should be drawn up from over the ship's side in a canvas bucket from a position right forward and two samples should be taken, the temperature of the *second* only being read. The temperature observations should be taken as soon as the bucket is hauled up.

Accurate temperature and humidity observations are of great importance in forecasting by modern methods — a knowledge of the temperature and humidity of the air assists in deciding upon its type. They are also of importance in forecasting visibility, perhaps the most important of meteorological phenomena to seamen, as one has to take into account the temperature of the wind and that of the surface over which it blows as well as the humidity prevailing at the time. Experience has shown that a change in the temperature of the air or of the sea surface may considerably affect the degree of visibility. An interesting case of this came to my notice recently: a ship navigating in coastal waters in good visibility found a very marked deterioration in visibility on the change of tide owing to the difference in temperature of the ebb and flood waters.

### 3. *THE ATMOSPHERIC PRESSURE OR THE HEIGHT OF THE BAROMETER.*

Pressure of the atmosphere is measured by means of a mercurial or an aneroid barometer. The mercurial barometer is mounted on gimbals so that it can remain approximately vertical even when the ship is rolling. It must be placed in a position to allow it to do this and at a convenient height so that the eye can be brought easily to the top of the mercury. The chart house is often the most convenient place for the barometer but the ideal position is the centre of pitch of the ship, where the vertical motion due to pitching is zero and that due to rolling is a minimum; the pumping of the barometer will then be a minimum. The pumping of the mercury caused by the movement of the ship in a seaway is reduced in a marine barometer by a constriction of the tube at the cistern end. The rise and fall of a ship in a seaway produces irregularity and when it is remembered that roughly speaking the barometer falls one thousandth of an inch (.034 of a millibar) for every

foot of increase of height, it is plain that the vertical rise and fall of a ship in rough weather may affect the readings by several hundredths of an inch. When the barometer is pumping it is necessary to take the mean of the highest and lowest readings of the barometer over a period of about five

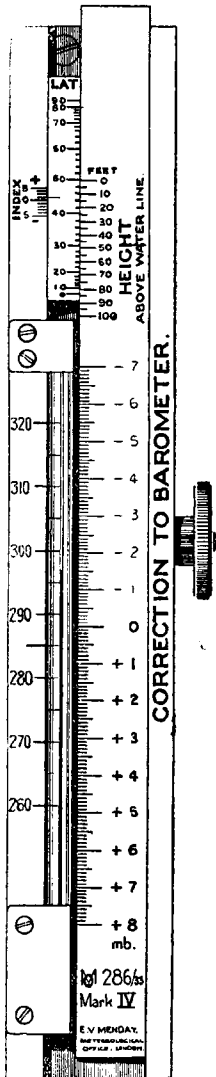


FIG. 13  
Gold slide  
for mercurial barometer.

minutes. A high degree of accuracy is required in the reading of the barometer, which must be reduced to sea level and corrected for temperature and latitude, when the reading is to be transmitted by W/T for the information of other ships or to be used for plotting on a synoptic chart (the construction of which will be described later). Correction tables are to be found in most nautical text-books used at sea. An ingenious device for automatically correcting the barometer, the GOLD slide (\*) (Fig. 13), is fitted to some barometers and saves reference to the correction tables. The opportunity should be taken at periodical intervals of checking the barometer against a standard instrument at a shore station.

The aneroid also measures pressure and is a particularly useful instrument in ships. It is in many ways more convenient than a mercurial barometer but it is not so reliable in measuring absolute pressure and consequently should frequently be compared with a mercurial instrument. The readings from this instrument do not require correction for temperature or latitude but only height above sea level (if the zero of the instrument has been previously adjusted correctly).

The barograph is an instrument for recording pressure and is a self-registering form of aneroid. It is a valuable supplement to the barometer since barograms show minor fluctuations of atmospheric pressure which are missed with the mercurial barometer even with hourly readings. The barograph should be carried in a cradle or spring suspension bracket and placed in the position least likely to be affected by vibration or movements of the ship. A knowledge of the change or tendency of the barometer which is easily obtained from the barogram is of greater importance to seamen in connection with the accurate forecasting of the weather than the actual height of the barometer. In estimating the true tendency in a ship

under way it is of course necessary to allow for the course and distance made good by the ship.

#### 4. WIND DIRECTION AND FORCE.

The direction and force of the wind are usually estimated by observing the appearance of the sea surface, the true direction being recorded in points

(\*) Invented by Colonel E. GOLD of the British Meteorological Office.

of the compass or in degrees and the force expressed on the BEAUFORT Scale. Unless the estimation is made by observing the effects of the wind on the sea surface, allowance has to be made for the speed and the course of the ship. In order to obtain greater accuracy, electric cup anemometers have been introduced in certain ships. The electric cup anemometer (Fig. 14) consists of 3 or 4 cups connected to a spindle which revolves with the wind. From the number of revolutions per minute the speed of the wind can be determined. To facilitate counting, the cup anemometer is connected in an electric circuit which operates a buzzer after so many revolutions. This instrument of course measures only the relative wind speed.

##### 5. *HORIZONTAL VISIBILITY, etc.*

A visibility scale for recording visibility at sea has been adopted internationally. At shore stations the measurement of visibility is a comparatively simple matter utilising objects at fixed distances. At sea it is more difficult owing to the lack of fixed objects but there is little doubt that seamen from years of experience are able to give a very good estimate of visibility. It is however almost impossible for anyone to estimate what the visibility would be if it were daylight from an estimate of the actual visibility prevailing at night. Unfortunately this is still being attempted all over the world (in making weather reports to shore meteorological services) and until there is a change of international practice it will have to continue. It has been considered until recently that it was inadvisable to use the horizon for estimating visibility at sea on account of the possible effects of abnormal refraction, particularly when the height of the eye was great. Recent investigations however appear to indicate that considerable displacements of the apparent horizon owing to abnormal refraction do not occur in practice and that the effect of differences in sea and air temperatures on the apparent position of the horizon is usually negligible. Further evidence is required before the point can be definitely settled and there is a useful field of enquiry here for the seaman interested in the meteorological side of his work.

The importance of accurate observations will soon be apparent to anyone preparing his own weather chart and making his own forecast — an erroneous pressure or temperature recorded on a chart may put an entirely different aspect on the position, particularly if there are relatively few observations available for plotting on the chart. Modern weather forecasting is mostly dependent on maps; and the synoptic chart which, as the name implies, gives a graphic representation of weather over an area at a particular moment, is the foundation on which forecasting rests.

The birth of synoptic meteorology dates back to 1854 when in November of that year a storm burst suddenly upon the British and French Fleets in the Black Sea and did tremendous damage. The French Astronomer, LE VERRIER, collected data which showed that the storm had travelled across Europe and might have been foreseen had telegraphic information been avai-

lable at a central office. LE VERRIER'S report made the British and French Governments move in the matter and LE VERRIER in Paris and FITZROY in London were able to establish an organisation for the exchange of weather reports from a number of stations from which the first regular synoptic charts were prepared. In those days, however, the difficulties of communication prevented the seaman from utilising the information obtained from land stations. The introduction of wireless telegraphy and the great advances made in this method of communication during the last quarter of a century have made it possible for ships regularly to obtain observations over a large area. Ships can communicate with one another and with land stations with great facility. Meteorological Services of many countries now broadcast weather information for shipping and ships equipped with W/T (as are all ships of any size nowadays) can take in the required information for constructing a weather chart and if officers are provided with the necessary knowledge of meteorological laws and methods used they will be in a position to make a forecast of the weather.

International co-operation is essential in establishing an efficient organisation for the rapid dissemination and collection of meteorological data; reports made by ships are of the utmost value to shore meteorological services, and ships, in their turn, are dependent on these shore services for meteorological data to complete their own synoptic charts. In order to promote uniformity in the dissemination of meteorological information an International Meteorological code has been adopted. The present form of this code was adopted at an international conference in Copenhagen in 1929. Unfortunately a few countries have not yet adopted it for use in their meteorological messages and still adhere to the earlier forms of code, so that complete uniformity has not yet been attained. The majority of meteorological services have, however, adopted the code and as it is very comprehensive, there is a strong possibility that the remaining services will eventually be able to come into line. The importance to seamen and airmen of the adoption of a uniform code cannot be over-emphasised; prior to the introduction of this international code the meteorologist attached to a world cruise of the *Graf Zeppelin* reported that he had to deal with over 70 different meteorological codes in the course of the cruise.

The modern forecaster requires synchronous observations from a network of stations extending over a wide area. A network is now available in nearly every part of the world; the appropriate meteorological service collects the information and codes it into the International Code and transmits it for the information of other shore stations and ships at times which are given in the various publications. Space does not permit the inclusion here of details of the code but full particulars will be found in standard publications such as the Admiralty List of W/T Signals and *Les Messages Synoptiques du Temps* published by the International Meteorological Organisation.

The decoded data are plotted on special blank charts on which stations are represented by small circles. The method of plotting the data varies in different countries; one method of plotting is as follows: The wind is repre-

sented by an arrow flying with the wind, with its head on the station, the force on the BEAUFORT Scale being represented by the number of feathers. For convenience it is better to put all the feathers on one side of the arrow, spacing them in threes, with any odd ones at the end of the arrow. The present weather is entered to the right of the station; BEAUFORT notation or special symbols are used for this. Past weather is entered to the left of the station similarly to the present weather but in *red*. Low, medium and high clouds are entered vertically in this order upon present weather. Either symbols or the standard abbreviations are employed for the cloud entries. The amount and height of the low cloud are entered in the code figures to the right of the low cloud entry. The total amount of sky covered with cloud is indicated by a number of vertical lines on the station circle. The barometer reading in millibars and tenths is entered below the present weather, followed by the tendency and amount of barometric change in the preceding three hours. If the net change has been upward this tendency is entered in *red*. The tendency is represented symbolically; e.g. — + means that the barometer fell at first and subsequently rose by a smaller amount than it fell. The initial 9 or 10 of the barometer reading is often omitted. The air temperature is entered below the barometer reading and the dew point (deduced from the humidity) report is entered in *red* to the right of the air temperature. Sea temperature is entered below the air temperature from which it is separated by a horizontal line. Visibility is entered to the right of the present weather; V9 means visibility 9 on the International Code. In ships' observations, the swell amount and direction are indicated by symbols and the course of the ship by a red arrow *pointing* in the direction of motion, with the approximate distance made good in the preceding 3 hours entered at the end of the arrow. These methods of plotting are illustrated in Fig. 15.

When all the data have been plotted on the chart, lines are drawn joining the places of equal pressure; the lines, known as isobars, are usually drawn for every 2 millibars. A typical chart drawn at sea is shown in Fig. 16.

A study of a series of synoptic charts constructed in this way shows that the isobaric formations occurring can be classified according to various types and until recently all forecasting was based upon this classification, definite sequences of weather being associated with each type of isobaric formation. The fundamental isobaric types are represented in Figs. 17-23 and the weather associated with each type (in the Northern Hemisphere) is described below.

Fig. 17. — *The depression*, low or cyclone, as it is variously termed, is a bad weather type and usually appears as closed isobars circular in shape with low pressure at the centre. The size of a depression may vary enormously and its rate of progression may be fast or slow. The average rate of travel is about 20 m.p.h. If it is intense it usually travels fast; if only of slight intensity it usually travels slowly; a depression in the course of filling up is usually stationary.



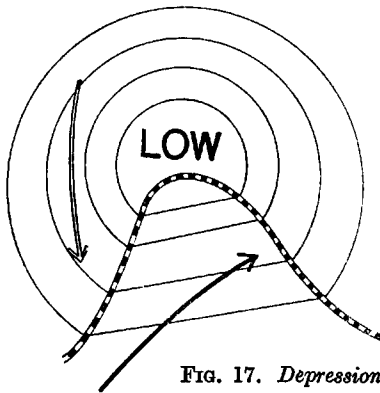
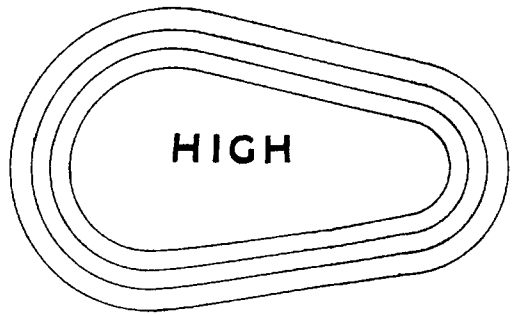
FIG. 17. *Depression.*FIG. 18.  
*Anticyclone.*

Fig. 18. — *The anticyclone* is a fine weather type and moves slowly and irregularly and often covers a large area. It may remain in the same position for days or even weeks without any great change taking place in the general conditions. Extensive cloud sheets sometimes form in anticyclonic weather but rain seldom falls.

Fig. 19. — *The secondary*. — A secondary usually travels forward in the same direction as the main depression and circles round the southern part of the main depression and may even outstrip it in rate of travel. They usually produce rain and sometimes much wind, some of the heaviest gales in the English Channel being caused by secondaries.

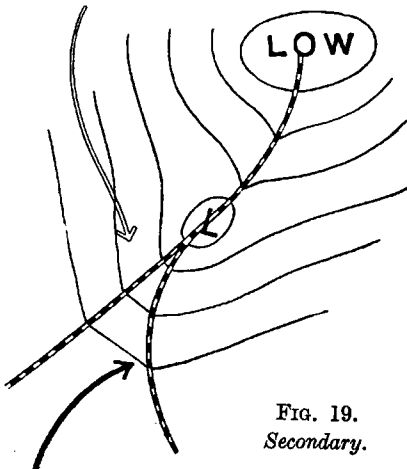
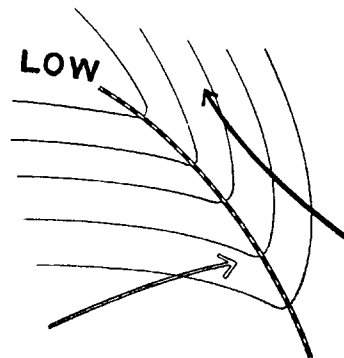
FIG. 19.  
*Secondary.*FIG. 20.  
*V-shaped depression.*

Fig. 20. — *The V-shaped depression*. — This type of depression is marked by squally winds and rain, the latter being caused by the proximity of a warm southerly current on the eastern side of the V and a cold northerly current on the western side. Line squalls are associated with V-shaped depressions (a line squall is a heavy squall of wind which is accompanied by the passage of a long arch of low black cloud from which heavy rain or hail falls for a short time. It is caused by the undercutting of a warm southerly air current of high relative humidity by a colder and denser westerly or north-

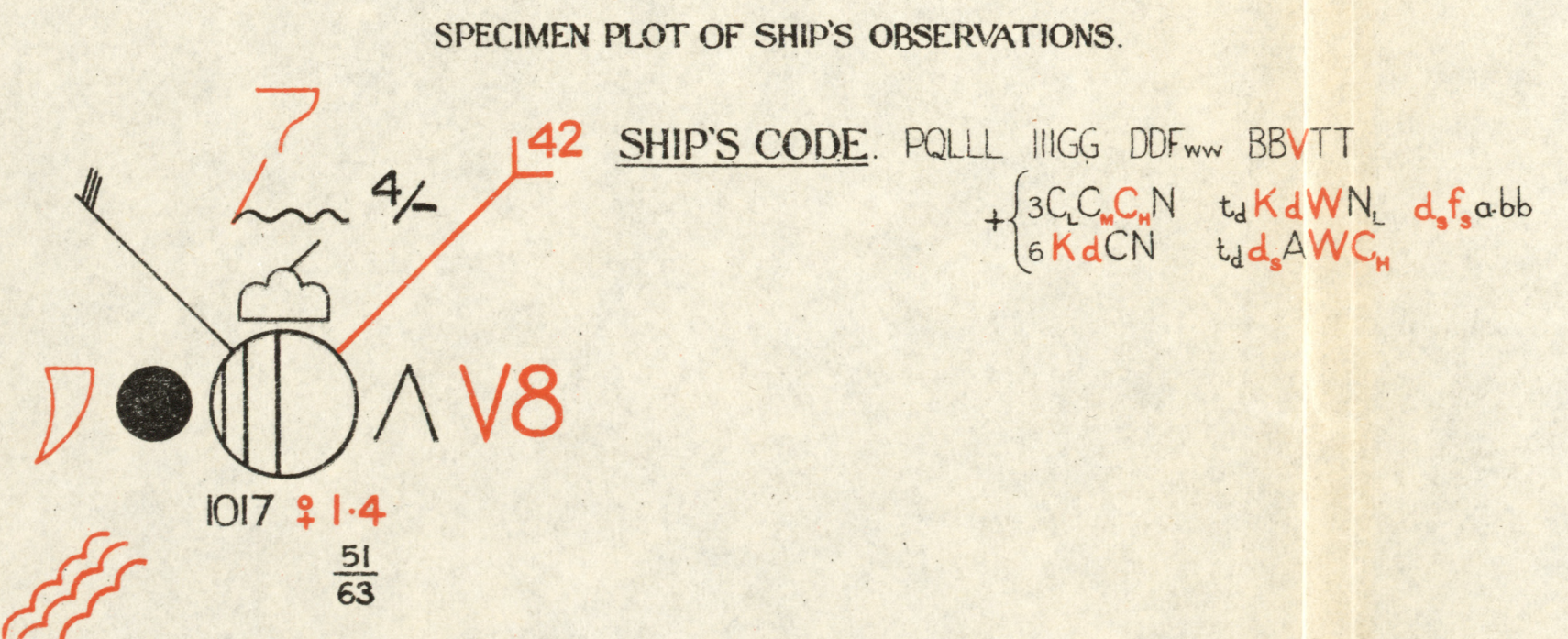
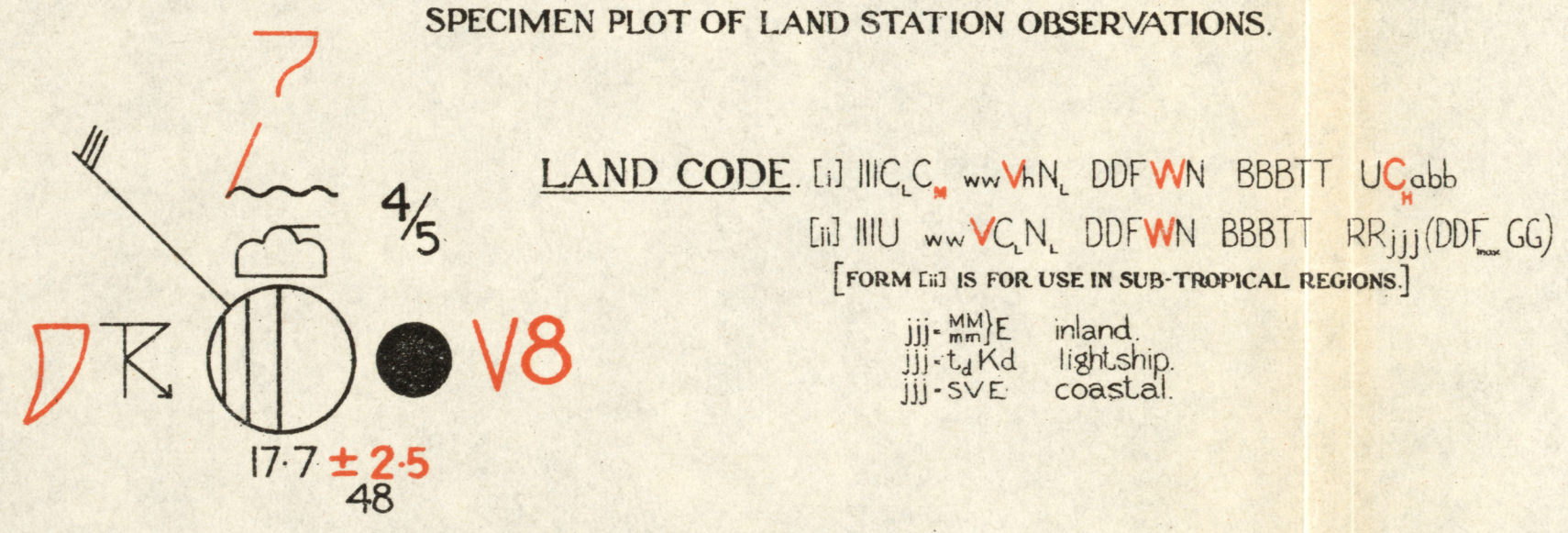


Fig. 15

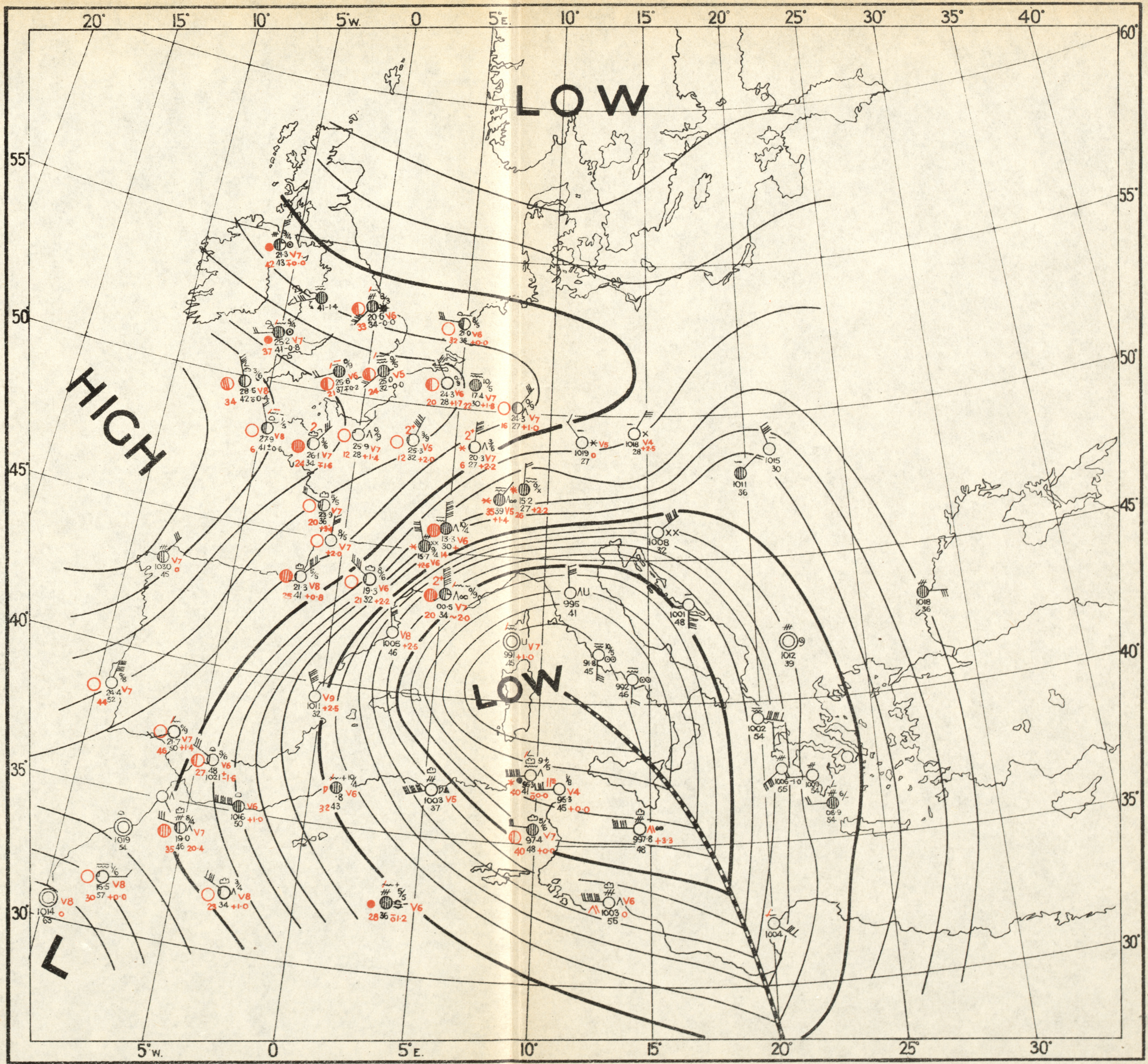


Fig. 16

westerly one. The warmer air is found to rise abruptly over the colder one and dynamical cooling takes place and low cloud and rain are produced).

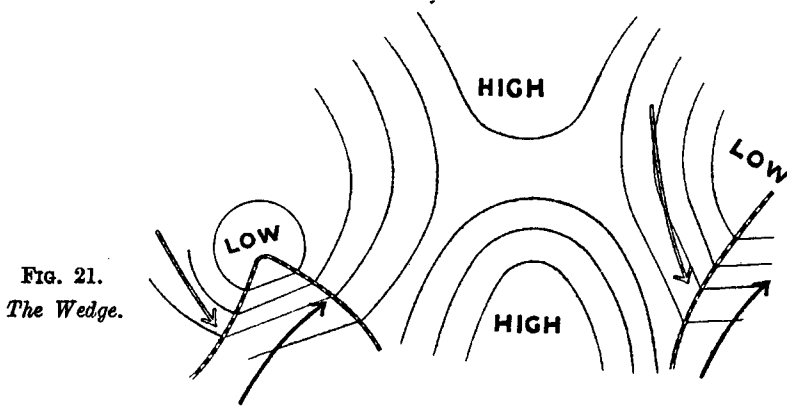


FIG. 21.  
*The Wedge.*

Fig. 21. — *The wedge.* — The wedge consists of wedge-shaped isobars enclosing an area of high pressure. After the passage of a depression, if the weather clears up very rapidly and the wind falls quickly, it is usually the sign of the approach of a wedge. In such cases fine weather may be expected for at least a few hours.

Fig. 22. — *The col.* — A col is a region of comparatively low pressure where light airs from different directions are brought into close proximity, and is often associated with conditions producing respectively low cloud and fog or thunderstorms. The different air currents may be of entirely different temperatures and relative humidities, and condensation by mixing is therefore given full opportunity to manifest itself, tending to the formation of fogs. Alternatively, with somewhat altered conditions, the mixture of two air streams with different physical properties facilitates the development of thunderstorms.

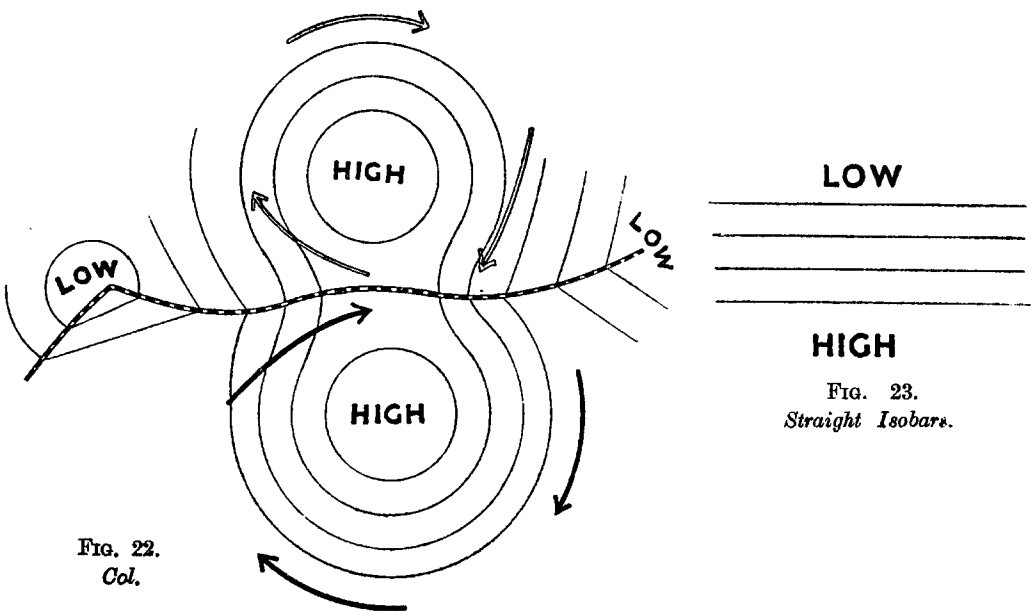


FIG. 22.  
*Col.*

FIG. 23.  
*Straight Isobars.*

Fig. 23. — *Straight isobars*. — Occasionally isobars run straight over a large area of the chart. In such cases a great diversity of weather is likely over the area in question, varying from overcast or cloudy skies with some rain towards the low side and blue skies towards the high pressure side of the band of isobars.

In forecasting one has to take into account, of course, the probable direction of movement of the pressure systems as well as their types (the barometric tendency is of particular importance in determining the most probable direction of movement of a pressure system). The weather sequence at any particular place for any period is in fact the weather associated with the succession of isobaric types which pass over that place during the period in question. From the estimated run of the isobars near any place at any time the direction of the wind at that time can be fairly accurately estimated by the use of BUYS BALLOT'S Law. A rough estimate of the force of the wind can also be obtained from the closeness of the isobars; the force of the wind is inversely proportional to the distance apart of the isobars; if they are close together the wind will be strong but if they are far apart the wind will be light. At sea the direction and velocity of the wind are unaffected by the configuration of the land and the temperature of the air is not subject to a large diurnal range, which gives the forecaster at sea some advantages over the forecaster on land; on the other hand, the former cannot have such a complete network of observations as the latter. Until comparatively recent times weather forecasting was to a large extent empirical, but knowledge of the processes at work in the atmosphere has greatly advanced and with the increase of knowledge seamen who seriously study the subject are able in an increasing degree to make scientific as opposed to empirical forecasts.

During the last two decades, however, a new way of regarding weather has been developing among meteorologists and today many of them consider that the subject is best studied in the light of the physics of air streams. The view-point is essentially a practical one; the weather at any place develops in the air stream flowing over it and any changes in this weather are brought about by physical changes in that air stream (e.g. cooling of the air stream by passage over a cooler surface tending to produce fog) or by its replacement by another air stream with different properties (e.g. the replacement of a south-westerly air stream by a north-westerly).

The principal air streams of middle latitudes may be divided into two main classes, air streams of polar origin (Polar air) and air streams of subtropical origin (Tropical air). Polar air is distinguished chiefly by relatively low temperature and a low specific humidity, a large vertical temperature gradient on the lower layers, visibility very good, predominating cloud of the cumulus type. Some rain, due to instability, irregularly distributed, is observed. Tropical air is distinguished chiefly by a relatively high temperature, a high specific humidity and a slight vertical temperature gradient. The typical cloud is stratus, visibility is generally not very good and drizzle often occurs within the air mass. These two main air streams flow towards one another, the warmer and lighter tropical air flowing up over the cooler and heavier

polar air along the surface where the two streams meet. This surface is called the Polar Front; it is not continuous round the earth, there being gaps where the two air streams have become so modified by local influences as to become very little different from each other in properties. Nor does the polar front intersect the earth's surface along a parallel of latitude, as would happen if the wind circulation were perfectly symmetrical. Actually, the symmetrical circulation of the winds is considerably modified by the pushing of the tropical air towards the north and the pushing of the polar air towards the south. The pushing of warm and cold air alternately produces waves in the surface of the polar front, which, according to the Norwegian school of meteorologists, who have been mainly responsible for developing this theory, give rise to the moving cyclones (depressions) of temperate regions. These waves on the polar front produce eddies in the wind circulation similar to the eddies produced at the boundary of two water-currents and these wind eddies are the depressions of middle latitudes.

According to this view, therefore, the depression consists of two essentially different air masses, polar air and tropical air. The structure of a depression is diagrammatically illustrated in Fig. 17. The tropical air on the southern side of the wave eventually impinges on the polar air stream in front and rises over it, producing cloud sheets and rain; the surface at which this occurs is called the warm front. On the rear side of the wave, the heavier polar air undercuts the lighter tropical air and forces it upwards, again producing cloud and rain. The surface along which this occurs is the cold front. From a consideration of Fig. 17 and the properties of the air streams given above it will be seen that the weather changes associated with the passage of a front in the middle latitudes of the Northern Hemisphere are as follows:

*Cold front.* — Wind veers from S.W. to N.W., usually decreasing in force. Sudden rise of barometer (due to heavier polar air). Drop in temperature and humidity. Improvement in weather generally often marked. Improvement in visibility. Cloud changes, after passage of front, to cumulus type.

*Warm front.* — Wind veers from S. or S.E. to S.W., often increasing in force. Fall of barometer ceases or rate of fall decreases. Rise in temperature and humidity. Cloud layer getting progressively lower but clearing after passage of front. Continuous rain increasing in intensity but ceasing at passing of front. Deterioration in visibility.

Although the depression only is discussed above in terms of air streams and fronts, any pressure type can be similarly analysed; to assist the reader the corresponding air streams and fronts have been inserted on the pressure types shown in Figs. 17-23.

On a synoptic chart the character of the polar and tropical air is not always easily distinguished and the temperature of the air given by a thermometer on the surface is not always a reliable guide owing to the effect of local heating. As a general rule, however, it will be found that it is polar air when the air temperature is less than the sea temperature and tropical air when the air temperature is greater than the sea temperature. When the air

mass or air stream in which the ship lies has been identified, the forecaster has to determine which fronts are likely to pass over the ship. When these points have been settled the weather sequence which the ship will experience can generally be reasonably well determined.

It is impossible of course to lay down definite laws on forecasting but with a knowledge of the physical processes of weather, a close study of isobaric changes and the movements of air masses and constant practice the seaman will be able to give a forecast which may often be of great aid to navigation. Forecasts based on popular weather prognostics may often be correct for a particular locality and indeed may often be of assistance to the forecaster in framing a more general forecast but many of them cannot be relied on. Red sky is perhaps the most popular of all weather omens. Red sky in the morning is often caused by high and medium clouds in front of a depression with the eastern horizon still clear. Red sky at night sometimes denotes an improvement after bad weather, but it is less reliable as a weather sign than red sky in the morning. Another popular saying amongst seamen is "First rise after low indicates a stronger blow"; this may refer either to the rise of barometer with the cold front which is accompanied by squalls or to the fact that one depression is generally followed by another. "Too fine to last" is often applied to that clear weather which is experienced with a "wedge". This prognostic is true because the wedge is only a temporary spell of fine weather and is quickly followed by renewed bad weather. Only a few of the many weather prognostics, however, will prove reliable on thorough investigation; the only reliable foundation for weather forecasting is a sound knowledge of the physics of the atmosphere.

Forecasters at sea will do well to remember that the occurrence of any of the ordinary incidents of weather, fog, cloud, rain, thunder, strong winds, etc. is not completely controlled by any single condition but is generally dependent upon a combination of circumstances. Of the conditions necessary for any occurrence one or more may be present and the occurrence fail for the want of a second or third. All the occurrences are displays of energy taking place in the atmospheric environment and speaking generally we may say that an occurrence of any meteorological incident requires first a suitable condition of this environment throughout the track; by studying the results we may know what sort of occurrence the atmosphere is liable to, if and when other conditions are satisfied. We know for example that when the temperature in air over the sea rises from the sea surface upwards, the air is liable to be foggy. If a current of cold northerly air is pushing southward over an area such as the North Sea it is liable to form cloud. If there is a large lapse rate of temperature, i.e. a rapid change of temperature with height, the atmosphere is liable to heavy rain, hail or thunder. The liability may not eventuate, however, because the necessary saturated air is not supplied.

The value of an accurate forecast of the approach of a tropical storm cannot be over-estimated. Meteorologists are not yet definitely agreed as to the method of formation of tropical storms but the "thermal" or "local heating" theory is probably the most popular. This theory assumes that the air

Some of the most interesting observations obtained in the earlier days were those of M. TEISSERENC DE BORT (French) and Mr. ROTCH (American), two enthusiastic amateur meteorologists who chartered the yacht *Octavia* and carried out a series of observations during three successive cruises in the years 1905-1907, with the object of exploring the region of the Trade Winds. Important discoveries were made by them, such as the discovery that temperature decreases with height up to a certain level only, and then remains constant, or even increases with height. The height at which this change takes place is about 37,000 to 40,000 feet in middle latitudes. Over the equatorial regions this decrease in temperature continues to a greater height than over the polar regions, the coldest region therefore, in the higher layers of the atmosphere, is over the equator and temperature increases from above the equator to the pole instead of decreasing as it does at the surface. The existence of an anti-trade (i.e. a wind above the trade blowing in an opposite direction) was another important discovery. The average depth of the N.E. trade wind is probably about 6,000 feet but the height at which the anti-trade is found varies considerably. Observations have shown that in one part of the South Atlantic the S.E. trade has been found to be about 3,000-4,000 feet deep with an anti-trade immediately above it. Valuable information regarding the upper air conditions over the South Atlantic has recently been obtained by the German research ship *Meteor*.

It is known that above the equatorial belt of calms a current from the East always exists, having a velocity which increases with height in the Pacific and Atlantic. In both temperate zones the currents are opposed to this, giving prevailing westerlies at all heights; the lower part of this westerly current is affected by the passage of areas of high and low pressures. The actual wind in the lower layers of the westerly current may therefore blow from any direction but the greater the altitude the more constant the westerly wind.

Observations over the monsoon region show that the depth of the N.E. monsoon at its northern limit is approximately 3,000 feet, its depth increasing steadily towards lower latitudes until it reaches 30,000 feet in the South of India. The structure of the S.W. monsoon is more complicated but we again find a progressive decrease in depth on passing from Southern to Northern India. Above each monsoon is an anti-monsoon (analogous to the anti-trade).

As a general rule in the latitude of the British Isles it may be said that westerly winds will increase with height whereas easterly winds will increase in the lower levels and then decrease, becoming reversed in direction at greater heights.

At the present time an effort is being made to investigate the upper air over the oceans not only on account of the direct utility of the observations in connection with the development of air routes but as a direct aid in forecasting. Unfortunately circumstances do not so readily permit of observations being taken over the sea. The difficulties of observation are increased by the unstable platform afforded by a ship, thereby often necessitating the use of a sextant instead of a theodolite, unless it be of special shipboard type. In spite of these difficulties, observations of upper winds and temperatures are being obtained by ships of the British Navy, by the United States Navy and

TABLE TO CORRECT BAROMETRIC PRESSURE FOR DIURNAL VARIATION.

LAT. 10° TO 20° N. IN ALL LONGITUDES AT SEA.

Ship's Time.	Northern Spring.		Northern Summer.		Northern Autumn.		Northern Winter.	
	Mbs.	Ins.	Mbs.	Ins.	Mbs.	Ins.	Mbs.	Ins.
4 a.m. ....	+ 0.8	+ .02	+ 0.7	+ .02	+ 0.8	+ .02	+ 0.3	+ .01
8 a.m. ....	- 1.1	- .03	- 0.9	- .03	- 0.9	- .03	- 0.9	- .03
Noon .....	- 0.9	- .03	- 0.6	- .02	- 0.7	- .02	- 0.6	- .02
4 p.m. ....	+ 1.3	+ .04	+ 1.2	+ .04	+ 1.3	+ .04	+ 1.4	+ .04
8 p.m. ....	+ 0.1	.00	+ 0.1	.00	- 0.1	.00	0.0	.00
Midnight .....	- 0.4	- .01	- 0.3	- .01	- 0.3	- .01	- 0.2	- .01

LAT. 10° TO 20° S. IN ALL LONGITUDES AT SEA.

Ship's Time.	Southern Spring.		Southern Summer.		Southern Autumn.		Southern Winter.	
	Mbs.	Ins.	Mbs.	Ins.	Mbs.	Ins.	Mbs.	Ins.
4 a.m. ....	+ 0.6	+ .02	+ 0.7	+ .02	+ 0.7	+ .02	+ 0.5	+ .02
8 a.m. ....	- 1.0	- .03	- 1.0	- .03	- 0.8	- .02	- 0.9	- .03
Noon .....	- 0.5	- .02	- 0.4	- .01	- 0.4	- .01	- 0.4	- .01
4 p.m. ....	+ 1.4	+ .04	+ 1.3	+ .04	+ 1.1	+ .03	+ 1.2	+ .04
8 p.m. ....	0.0	.00	- 0.1	.00	- 0.2	- .01	- 0.2	- .01
Midnight .....	- 0.5	- .02	- 0.4	- .01	- 0.4	- .01	- 0.5	- .02

FIG. 24

The above Table shows the amount to be added to (+) or subtracted from (-) the corrected reading of the ship's barometer to obtain the pressure corrected for diurnal variation, for comparison with the normal pressure deduced from the atlas.

The problem of weather forecasting at sea is often complicated by the lack of information as to what is happening in the upper air; it will not often be possible for ships of the Mercantile Navies to obtain the information for themselves by means of pilot balloons, as explained later in this article, but most countries broadcast upper air data (with the surface observations), which can be used by ships intercepting the message. Further, knowledge of the probable changes in the upper air is of essential importance to aircraft, and as eventually aircraft will be carried in many merchant ships as a means of transporting mails as rapidly as possible, the study of the upper air conditions should not be neglected by navigators and upper wind charts for the oceans similar to the surface wind charts should be prepared by all services or by some international body. As early as the beginning of the 20th century the work of exploration of the upper air by means of balloons and kites was officially under way in some countries but over the sea areas the number of observations obtained was very few; America, France, Germany, Great Britain have all contributed some such observations but a very large number are still required.



over a restricted region is heated to a higher temperature than its surroundings, thus becoming unstable and capable of rising upwards. It is not difficult to visualise the effect of local heating combined with saturation as yielding the energy required for a vigorous circulation and ascent of air; we have now to look for a physical cause sufficiently powerful to produce the heating required over a limited area. Over the ocean the effect of solar radiation is slight but the regions in which these storms originate are near the eastern shores of one or other of the continents and are studded with small islands. They are also regions of conspicuously high sea surface temperature and the air in which they originate has probably originally travelled over a large stretch of warm water over which large scale convection would be expected readily to take place. The torrential rain in tropical cyclones is in itself evidence of the convection of damp air. The horizontal removal of air carried up by the convection currents requires that at some height there shall be a marked change of wind direction or velocity so that the air which rises to the level shall be removed from the column in which it ascended. Thus two conditions are necessary for the formation of a tropical storm; firstly we require a supply of warm moist air capable of rising through its environment and secondly we require a marked change of wind at some height in free air. If the first condition alone were sufficient it would be difficult to understand why tropical storms are not much more frequent. It is the necessity for the second condition which apparently limits their frequency. In the absence of favourable conditions in the upper air it is probable that the effect of thermal convection is merely to produce a thunderstorm. Tropical storms have their peculiarities in the different regions in which they occur and if facilities are available for obtaining weather information and a synoptic chart is constructed it is usually possible to follow the track and movement of the storms; by carrying out this procedure a ship can normally avoid the unfortunate predicament of finding herself in or near the centre of a storm.

The weather signs which foretell the approach of tropical storms are so well known to all seamen that it is unnecessary to recount them here. It is too often stated, however, in nautical text-books that one of the first signs of a tropical storm is the cessation of the diurnal range of pressure. The cause of the diurnal range is one that affects the atmosphere of the earth as a whole and it is difficult to conceive how a disturbance embracing a comparatively small area could cause a cessation of the atmospheric oscillation even in the neighbourhood of that disturbance. The diurnal variation is undoubtedly masked by the rapid fall of pressure but the diurnal variation is still present. A surer sign however is the departure from normal of the pressure and it is a wise precaution when in regions where tropical storms occur, to make a comparison once a day between the observed pressures corrected for diurnal variation from the table given in Fig. 24 and the normal pressure for the month taken from the pressure charts in the meteorological atlas. If there is an appreciable difference between the corrected existing pressure and the normal pressure the approach or development of a tropical storm is indicated.

by German ships. With such observations extending over a large number of years it is hoped that it will be possible in time to produce charts showing the normal direction and velocity of the winds at various altitudes over the sea. In these days of pleasure cruises which are now extending and increasing annually it is hoped that steps will be taken at no distant date to instal pilot balloon equipment on board and for regular observations to be taken daily. With this in mind it is not out of place in this article to describe the usual methods of obtaining winds and temperatures in the upper air over the sea.

*Upper winds.* — The movements of a rubber balloon are observed by means of a special theodolite, or a sextant and compass. The balloon is inflated with a certain amount of hydrogen so as it may rise at a fixed rate of 500 or 700 feet per minute. Observations of altitude and bearing are obtained every minute and from these data the direction and velocity of the upper currents can be calculated.

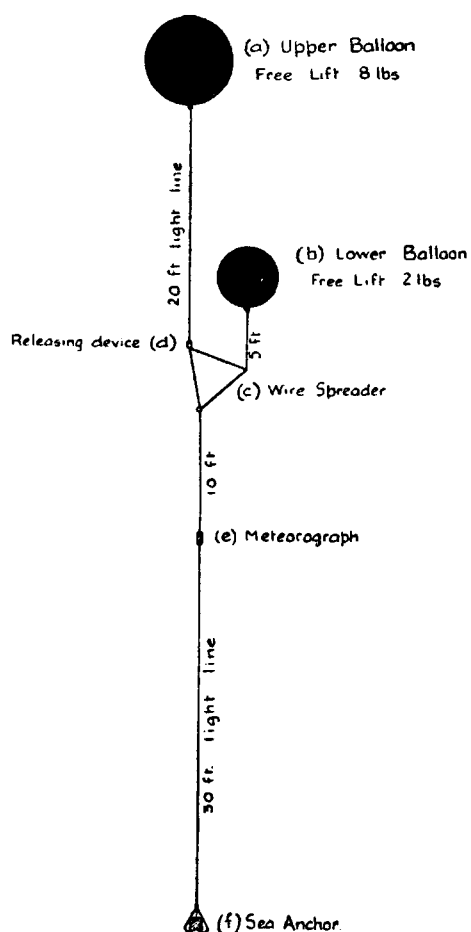


FIG. 25.  
Apparatus for determining  
upper air temperatures over the sea.

*Upper air temperatures.* — Balloons, much larger than those used for the purpose of obtaining upper winds, are sent up carrying meteorographs, instruments which record temperature, humidity and pressure. From the records of temperature and pressure the height at each stage of the ascent is readily deduced.

Two balloons are sent up in tandem with the meteorograph attached as shown in Fig. 25. On attaining a great height, say 24,000 feet or so, the upper balloon will burst — or if the sea room is limited a device may be attached by which the upper balloon may be released at a pre-arranged height. The remaining balloon, unable to support both the instrument and a float which is attached, comes down until the sea-anchor float touches the water. The balloon is now able to support the instrument some feet above the surface of the water until recovered by the ship which has followed it.

In the foregoing pages I have endeavoured to show how the study of meteorology may be of benefit to seamen and how its practical application may be a definite aid to navigation and to the safety of life at sea. The

development of meteorological science during the last three quarters of a cen-

ture is a practical demonstration of the value of cooperation, both international and inter-service. Without cooperation between the meteorological services of different countries and between seamen and shore meteorologists, meteorology could not have made such progress as it has. There is still, however, much to be done in the direction of closer co-operation; particularly among the more distant countries which have hitherto built their services almost independently of European countries and of one another. The International Convention on Safety of Life at Sea which was signed on May 31st, 1929, by eighteen nations makes important references to co-operation in meteorological work and it is to be expected that as a result of its adoption closer co-operation between all nations will ensue. Article 35, Chapter V, of this convention particularly refers to meteorology and reads as follows:—

“The contracting Governments undertake to encourage the collection of meteorological data by ships at sea, and to arrange for their examination, dissemination and exchange in the manner most suitable for the purpose of aiding navigation. In particular the contracting Governments undertake to co-operate in carrying out, as far as practicable, the following meteorological arrangements:—

“(a) to warn ships of gales, storms and tropical storms, both by the issue of wireless messages and by the display of appropriate signals at coastal ports;

“(b) to issue daily, by radio, weather bulletins suitable for shipping, containing data of existing weather conditions and forecasts;

“(c) to arrange for certain selected ships to take meteorological observations at specified hours, and to transmit such observations by wireless telegraphy for the benefit of other ships and of the various meteorological services; and to provide coast stations for the reception of the messages transmitted;

“(d) to encourage all shipmasters to inform surrounding ships whenever they experience wind force of 10 or above on the BEAUFORT scale (force 8 or above on the decimal scale).

“The information provided for in paragraphs (a) and (b) of this article will be furnished in form for transmission in accordance with article 31, (1), (3) and (5) and article 19 (25) of the General Regulations annexed to the International Radiotelegraph Convention, Washington, 1927, and during transmission “to all stations” of meteorological information, forecasts and warnings, all ship stations must conform to the provisions of article 31 (2) of those General Regulations.

“Weather observations from ships addressed to national meteorological services will be transmitted with the priority specified in article 3, Additional Regulations, International Radiotelegraph Convention, Washington, 1927.

“Forecasts, warnings, synoptic and other meteorological reports intended for ships shall be issued and disseminated by the national service in the best position to serve various zones and areas, in accordance with mutual arrangements made by the countries concerned.

“Every endeavour will be made to obtain a uniform procedure in regard to the international meteorological services specified in this Article, and as far as is practicable, to conform to the recommendations made by the International Meteorological Organisation, to which Organisation the contracting Govern-

ments may refer for study and advice any meteorological questions which may arise in carrying out the present Convention".

With the development of Civil Aviation and the opening up of air routes over the sea in all parts of the globe, meteorology has entered upon an enlarged sphere of usefulness. On land an elaborate network of weather reporting stations has been built up for the benefit of aviation. For reports from sea areas, however, the airman is still dependent almost entirely on the co-operation of ships and is likely to continue to be so. The organisation of ocean flying routes is receiving considerable attention at present; various projects have been put forward for the mooring of colossal seadromes in positions across the Atlantic, for instance, and experiments are being made with ships stationed in various positions to act as refuelling stations. If such stationary oceanic bases can be established they will be invaluable for meteorological purposes; reports from these bases, however, could not replace reports from ships, as the number of bases would not be sufficiently large. The value of the bases would appear to lie mainly in their usefulness as stations for collecting reports from ships and re-transmitting them *en bloc* to aircraft. The establishment of island meteorological services such as that of Bermuda (which was opened in 1931) also considerably facilitates the development of ocean flying routes; these services, however, are themselves dependent upon the co-operation of ships for the success of their meteorological work.

It will be seen therefore that the co-operation of seamen is essential to the further development of aviation and meteorology. One can say with confidence that this co-operation, which has been invaluable to meteorology in the past, will be forthcoming whenever required.

