

If the limit of approximation of the measured temperature is fixed at 1/10th degree, either the *decimal* or the *mean* method may be used for the determination of T_1 ; and that is the case always when the value of C is $\leq 2^\circ$.

If thereafter $2^\circ \leq C \leq 3^\circ$ has been obtained, only the *decimal* method must be applied.

It may happen that the difference between the temperature of the locality where the instrument is usually installed and that of the exterior is greater than 3° . In such a case it is necessary, before carrying out the observation of T_1 , to bring the temperature of the thermometer as nearly as possible to that of the air.

For this purpose the ventilator mechanism is wound up a few minutes before the observation is to be taken (6 or 7 minutes are amply sufficient in practice) and, meanwhile, the instrument is transported to the bridge. The thermometer is suspended from one of the sides of the charthouse (where care will have been taken to have ready a suspension system similar to that fitted up in the place where the thermometer is usually installed), in such a way that no possible spray may reach it.

About five minutes afterwards the measurement of the temperature may be proceeded with in the usual way.

For self-evident reasons it is indicated that the thermometer be placed on the windward side during the preliminary exposure made outside the charthouse.

It is recommended to test from time to time the ventilator rotating device, and when variations are observed, it is necessary to calculate new values for t_h and t_d . Another precautionary measure is to transport the thermometer from a locality at a lower to a locality at a higher temperature and *vice versa*, so that it may be ascertained whether in such circumstances the methods of measurement explained above give adequate values for T_1 .

NOTES

- (1) N. RUSSELLVEDT: *Measurement of temperature on board ships*. Geofysiske Publikasjoner, Oslo, Vol. II, 1936.
- (2) J. THOULET: *Instruments et opérations d'Océanographie pratique*. Paris, Chapelot, 1908.
- (3) L. MARINI: *Manuale per le osservazioni meteorologiche a mare*. Mem. R. Comitato Talassografico Italiano, Venezia, 1912.
- (4) *Norme per le osservazioni meteorologiche a bordo delle navi*. Istituto Idrografico della Marina. Genova, Editions 1910-1912 and 1930.
- (5) N. RUSSELLVEDT, *loc. cit.*
- (6) N. RUSSELLVEDT, *loc. cit.*, p. 5.
- (7) In the analytical treatment which follows, the symbols used by the author in the original treatise have been retained.
- (8) It should be noted that the indices h and d affixed to the signs t and T refer to the times and temperatures of the *mean* and of the *decimal* methods respectively.

AUTOMATIC BRAKE SOUNDING MACHINE

by

F. G. ENGLE, COMMANDER, RETIRED; U. S. COAST AND GEODETIC SURVEY.

(Extract from *Field Engineers Bulletin* N° 11, Washington-December 1937).

Sounding machines, with improved control mechanisms and automatic brakes, designed by Commander ENGLE, were used for the first time during the past season by the Ships *Surveyor* and *Discoverer*. The Commanding Officers of these two vessels report that the machines proved to be definitely superior to sounding machines formerly used and the automatic brake was a very desirable feature. This ingenious device permits the wire to pay out rapidly and stops the reel automatically when the bottom is reached. This results in a saving of time and more accurate soundings as the wire is not allowed to pay out after the lead strikes bottom. Commander ENGLE's description of the sounding machine follows.

(EDITOR).

This machine is for use with a 30-pound sinker in connection with a power drive unit, such as an electric motor, gasoline engine or launch propelling engine. The drive shaft extends beyond the frame and has a keyway for fitting a gear for chain drive or a pulley for belt drive from the power unit.

The reel revolves on a steel shaft, which is threaded into the frame on the operating side, and which carries a split collar in a housing formed in the hub of the reel. Rotating the shaft about 30 degrees, by means of the control handle keyed to it, moves the reel laterally between a cone friction brake attached to the operating side frame and the cone friction drive. Wire is payed out by the slipping of the reel on the cone brake and it is hove in by engagement of the reel with the drive friction cone, the reel revolving freely on the shaft. The drive member is a hollow shaft fitted in the frame bearing and over the fixed control shaft.

An automatic brake is provided to stop the reel instantly when the sinker reaches bottom. This brake is of the band type and is actuated by a spring exerting a tension of from 40 to 70 pounds. The spring exerts its tension in the direction of rotation of the reel when paying out, so that the inertia of the reel assists the spring in tightening the brake when it comes into action. The band brake is held in the off position by a catch, or trigger, as long as there is sufficient tension on the wire to hold down a tension pulley against the action of two springs. This tension pulley rotates freely on a bar connecting two arms. The two arms rotate on bearings concentric with the shaft under the action of a spring on each arm. The sounding wire is taken off the under side of the drum and over the tension pulley and is then led over the registering sheave.

The trigger holding the band brake in the off position is released by a cam on the tension pulley arm, the cam being adjustable on its arm to allow for different angles of lead of the wire between the drum and the registering or fair-lead sheave. It is so placed that the trigger will be tripped only after the tension pulley assembly has rotated 15 or 20 degrees from the position it occupies under the normal restraining tension of the wire when paying out at suitable speed. As a restraining or paying out tension of the sounding wire of from 5 to 10 pounds will be required for proper operation of the automatic brake mechanism with ordinary angles of lead of the wire, a sinker weight of not less than 30 pounds will be necessary, and the fair-lead sheave should be mounted low and well in front of the machine to keep the lead of the wire low and thus extend the tension arm springs as much as possible when paying out.

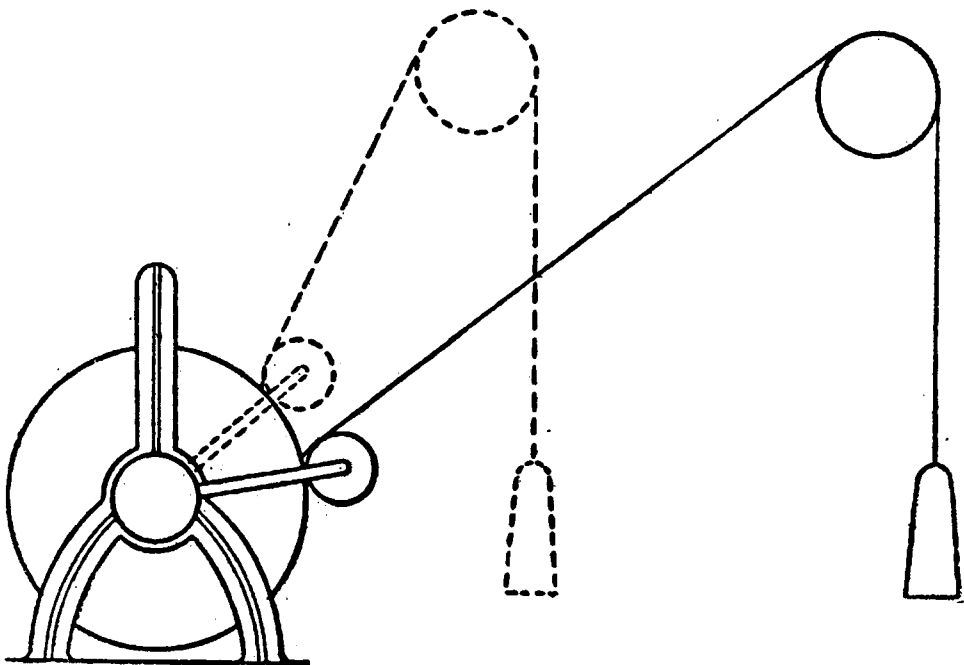

Automatic Brake Sounding Machine.

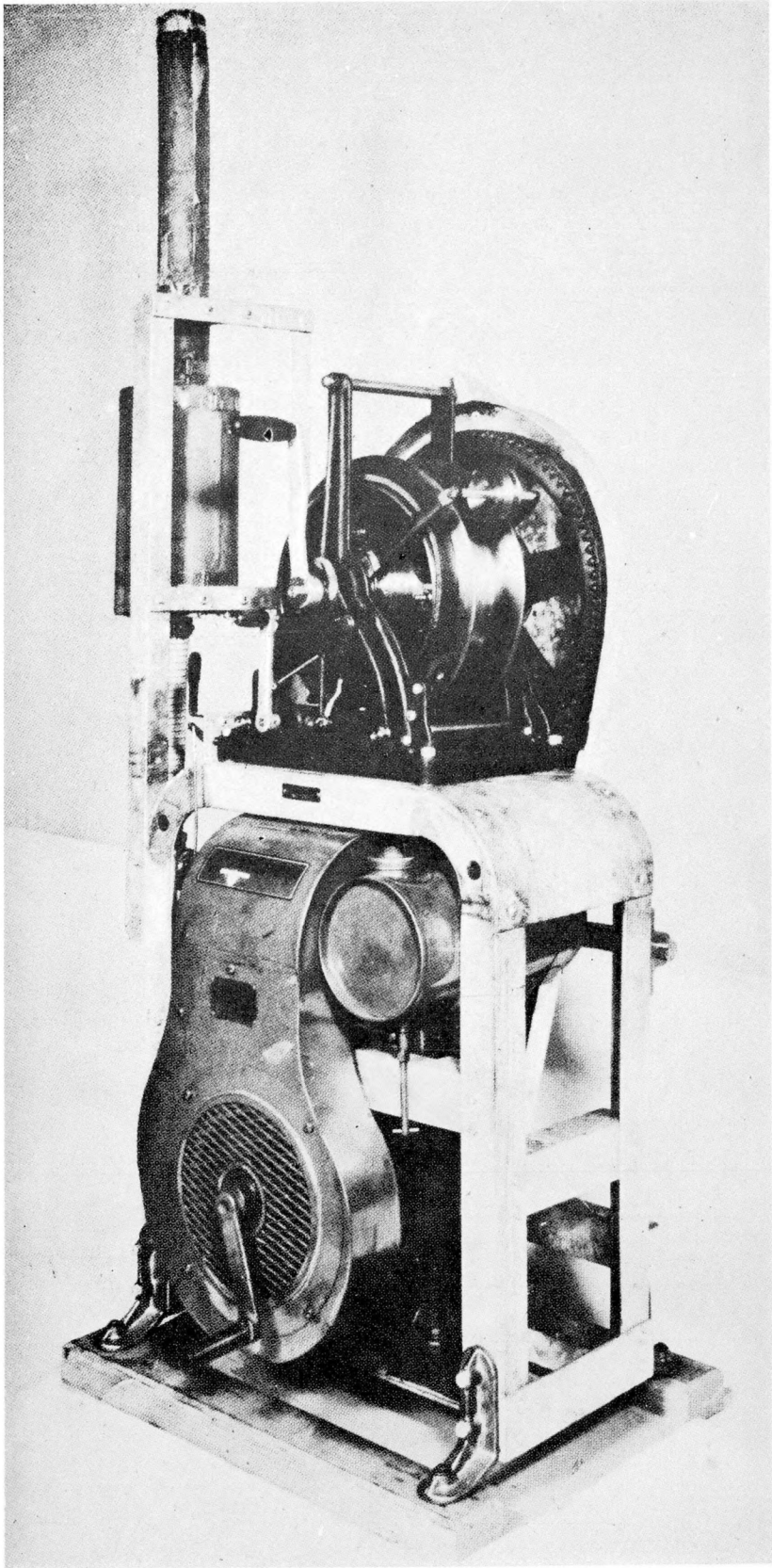

Montage de la Machine à sonder.

Sounding Machine Mounting.

PART NAME	MAT REQD SHEET	PART NAME	MAT REQD SHEET	PART NAME	MAT REQD SHEET	PART NAME	MAT REQD SHEET	PART NAME	MAT REQD SHEET
1 CONTROL	STEEL	10 SHAFT COLLAR	STEEL	19 BRAKE TRIGGER SHAF	STEEL	28 HAND BRAKE CONE ADJUST	STEEL	37 CONTROL HANDLE	STEEL
2 FRAME DRIVE	C BR	11 FRAME SPRINGS	STEEL	20 HAND BRK SPRNG	C BR	29 CONTROL HANDLE	C BR	38 TENSION ARM SPRING SH	C BR
3 REEL	C BR	12 FRAME SPRINGS	STEEL	21 HAND BRK SPRNG	C BR	39 TENSION ARM SPRING SH	C BR	40 TENSION ARM SPRING SH	STEEL
4 CLUTCH CONE	C BR	13 BRAKE TRIGGER	STEEL	22 TENSION ARM SPRING SH	C BR	41 TENSION ARM SPRING SH	C BR	42 INTERLOCK R & L	STEEL
5 CLUTCH PULLEY	STEEL	14 BRAKE RELEASE SHAF	STEEL	23 TENSION ARM SPRING SH	C BR	43 TENSION ARM SPRING SH	C BR	44 TENSION ARM SPRING SH	STEEL
6 CLUTCH BEARING PLATE	STEEL	15 FRAME DRIVE SHAF	STEEL	24 AUTO BRAKE CAM	STEEL	45 TENSION ARM SPRING SH	C BR	46 TENSION ARM SPRING SH	STEEL
7 CONTROL SHAF	STEEL	16 BRAKE BAND	STEEL	25 FRAME DRIVE	STEEL	47 GEAR GR PULLEY	C BR	48 FRAME SPACER BOLTS	STEEL
8 BRAKE SPRING	STEEL	17 BRAKE TRIGGER CATCH	STEEL	26 PUSH ROD GUIDE	STEEL	49 BRAKE RELEASE SPRING	STEEL	50 GREASE DEFLECTOR	STEEL
9 BRAKE RELEASE CAM	STEEL	18 BRAKE RELEASE CATCH	STEEL			51 GREASE DEFLECTOR	STEEL	52 TENSION ARM WASHER	STEEL
						53 TENSION ARM WASHER	STEEL	54 TENSION ARM WASHER	STEEL
						55 TENSION ARM WASHER	STEEL		

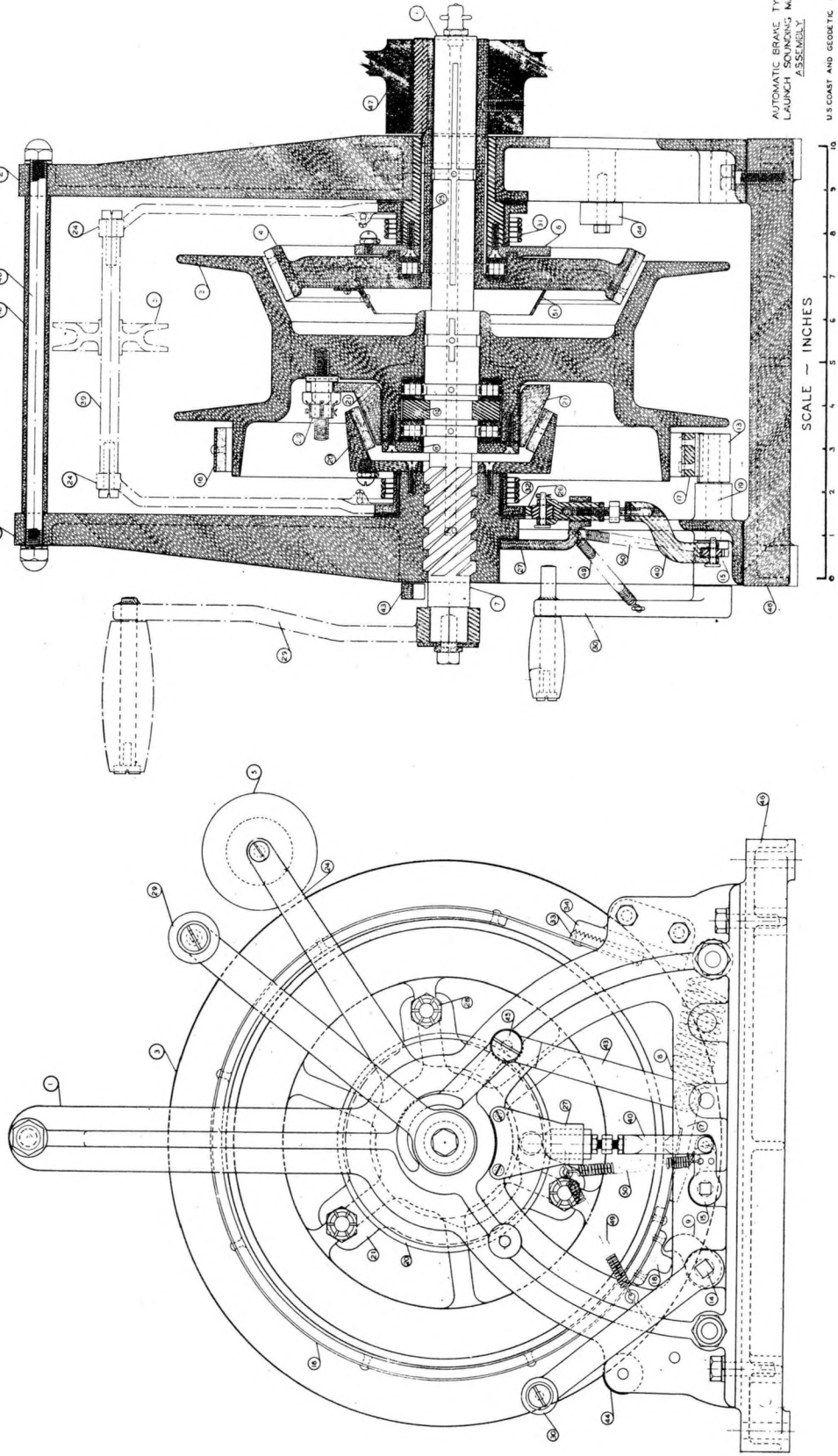

AUTOMATIC BRAKE TYPE
LAUNCH SOUNDING MACHINE
ASSEMBLY

U.S. COAST AND GEODETIC SURVEY

Dotted lines show improper mounting of fair-lead and consequent position of tension arms when paying out. Full lines show proper mounting.

Before paying out the reel is held against the cone brake by the control handle with only enough pressure to keep the reel from rotating under the weight of the sinker. The automatic brake is then released by means of a handle provided for this purpose and the wire is allowed to pay out at suitable speed under the restraint of the hand brake. Sufficient restraint must be held on the wire by means of the hand brake to keep the tension pulley down several degrees below the point where it will trip the brake trigger. If the wire is allowed to pay out too fast the tension of the wire will be decreased to a point where the tension pulley arms will spring up and release the automatic brake trigger before the sinker reaches bottom. With a sinker of about 30 pounds weight it should be possible to pay out at a speed of 150 to 200 fathoms per minute in depths up to 200 fathoms.

When the sinker strikes bottom and the wire slacks the tension pulley arms will rotate under the action of their springs, tripping the brake trigger and taking up the slack in the wire resulting from the rotation of the reel between the instant the sinker strikes bottom and the stopping of the reel by the brake. As the brake action is very positive most of the slack is due to the inertia of the tension pulley assembly which causes a slight delay in tripping the brake.

When starting to heave up, the band brake must first be released by the handle provided for the purpose. The control handle is then rotated clockwise to the clutch position and only sufficient pressure should be applied to the control handle in heaving up to prevent the clutch from slipping. As the leverage between the control handle and reel motions is quite high, considerable pressure is exerted on the clutch by a moderate pressure on the control handle. Excessive force on the control handle in either the brake or clutch position will severely strain the frames.

For holding the weight of the lead on the hand brake, the latter can be held in the applied position by means of a heavy rubber band or section of inner tube secured to a standard attached to the frame, the other end of the rubber band being slipped over the control handle in such a way that it can be detached quickly.

The pressure of the clutch against the frame, and of the shaft collar in the reel housing, is taken on three roller thrust bearings, lubricated through the drilled shaft and oil grooves from an alemite fitting in the end of the shaft.

As the clutch and cone brake linings wear, the throw of the control handle between the clutch and brake positions will increase. It can be brought back to the desired amount by means of the three adjusting nuts securing the cone brake drum to the reel. The adjustment should be made by turning each nut about one-half turn at a time, being careful not to bind them, and repeating the process until the desired throw is secured.

An adjustment for wear of the automatic brake lining is provided by means of a bracket having a notched surface and a slot for the bolt which secures the end of the brake band to it by means of a similarly notched block attached to the brake band.

An interlock is provided to prevent the application of the automatic brake when the clutch is engaged and conversely to prevent the engagement of the clutch until the automatic brake has been released. This interlock consists of an offset crank, which pivots on a shoulder screw attached to the frame. The lower arm of the interlock is attached to the movable end of the automatic brake band and the upper arm is formed so as to land on the control arm hub if the brake trigger is accidentally tripped while the clutch is engaged and prevents the application of the brake. When the automatic brake is in the applied position, the upper end of the interlock interposes between the control arm hub and the frame hub, preventing the engagement of the clutch.

Provision is made for left-hand as well as right-hand operation of the machine, that is leading the wire from the left side of the machine as viewed from the operator's position, as well as from the right side. This is accomplished by providing the front frame with opposite, drilled bosses for the trigger and brake release shafts and holes for attachment of the brake adjusting bracket and the interlock.

Right and left-hand brake brackets and interlocks are furnished as these parts are not reversible.

The machine can be dismantled readily by sliding the operating side frame and attached brake assembly off the shaft. To do this, release the automatic brake on its trigger; remove the two operating frame holding down studs, the control and brake release handles, the tension pulley shaft stud, the top frame spacer nut, the lower left frame spacer nut and the rear lower

right frame spacer nut. It will be necessary to rotate the shaft in the frame as the latter is withdrawn and the weight of the reel should be supported on the wooden wedge provided for this purpose when withdrawing the frame.

In assembling, the automatic brake should be in the release position so that it can slide on over the brake drum. The frame holding down studs should be set up tight before the frame spacer nuts are tightened. The machine should never be operated with the spacer nuts loose as the spacer bolts must take the thrust of the clutch and hand brake. This is considerable, due to the high leverage of the worm screw, and the machine may be damaged if operated with the spacer nuts loose.

The bolt holding the end of the band brake to its bracket should be kept tight as there is a strong tension on the band when the brake acts to stop the reel. As the band lining wears, it should be compensated for by adjustment in order to keep the brake spring effective and for proper operation of the interlock.

When heaving in, it will be necessary to lay the wire evenly on the drum by drawing the bight of the wire from side to side as with other machines. The tension pulley shaft and other working parts should be kept well lubricated but care should be taken not to use too much oil in the shaft alemite oiler, for it may find its way to the cone brake and clutch friction linings. Grease should not be used.

If desired, the machine can be operated without the automatic brake by not reeving the wire over the tension pulley, or by removing the band brake.

When the machine is not in use, the automatic brake should be tripped so as not to weaken the brake spring by keeping it fully extended.

TRIANGULATION BEACON LAMPS : TYPE COOKE, TROUGHTON AND SIMMS

(Extract from article : *The Re-Triangulation of Great Britain*
by Major M. HOTINE, R. E. - *Empire Survey Review*, No 29, Vol. IV, London, July 1938).

BEACON LAMPS.

The design of electric directional projector used has been altered slightly as the triangulation

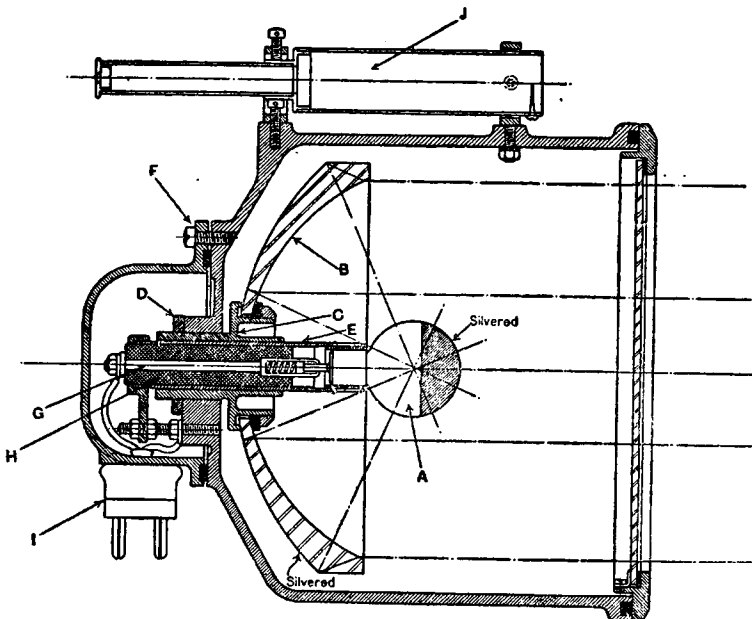

Standard Electric Beacon.