

R. N. SURVEYING SHIPS AND BOATS.

H.M. Surveying Ships consist of four ships in Home Waters, H.M.S. *Franklin*, *Scott*, *Seagull* and *Sharpshooter* which are all nearly the same class as H.M.S. *Franklin*, described in the *Hydrographic Review*, Vol. XVI, May, 1939. In addition they are fitted with radar giving ranges, accurate to 15 yards, up to 50,000 yards; Decca; Taut Wire Measuring Gear; Asdics for locating wrecks; Oropesa and Drift Sweeping gear to determine the least depths over wrecks and obstructions; besides ships' and boats' echo sounding gear.

Eight Surveying Motor Launches, of the 72 foot H.D.M.L. type, are also employed on the coasts of the British Isles. One or two are usually attached to a Surveying Ship, and others may work independently in pairs for sweeping wrecks with a wire sweep. A new type of Surveying Motor Launch is being developed, to replace those in service, in the near future.

Overseas, H.M.S. *Challenger*, described in the *Hydrographic Review*, Vol. VIII, November 1931, is employed in the Persian Gulf and Mediterranean and H.M.S. *Dampier*, lately converted for surveying, will sail for the Far East in the Spring of 1948. Other ships projected will be named H.M.S. *Dalrymple*, *Cook* and *Owen*. Improved versions of this latter class are visualised which will incorporate complete chart printing equipment.

A new 29 foot surveying Motor Boat has been designed, and a new 27 foot Surf Boat and a 14 foot Surf Boat are in service. The 27 foot Surf Boat is a considerable improvement on the 27 foot, naval whaler, both in sailing qualities and for landing through a surf.

H.M. Surveying Ship "DAMPIER"

Built by Smith's Dock Co. Ltd., Middlesbrough.

Launched : 1945.

Length : 307 feet.

Beam : 38 1/2 feet.

Draught : 12 1/2 feet.

Displacement : 2280 tons.

Engines : 2—4 cylinder triple expansion.

Makers : Smith's Dock Co. Ltd.

Horse Power : 5500.

Speed : 19 knots.

Fuel Stowage : 580 tons.

Endurance : 7000 miles.

Complement : 11 Officers, 156 men, including 6 Surveying Officers and 12 Surveying Recorders.

Boats : 3—28 ft. Surveying M. Bs. 2—27 ft.

Surf Boats; 1—32 ft. Motor Cutter. 2—16 ft.

Motor Skiffs; 2—14 ft. Surf Boats. 2—10 ft.

Pram dinghies.

Anchors and Cables : 2—2000 lbs. Danforth anchors ; 1—500 lbs. Danforth stern anchor; 1—800 lbs. Kedge anchor; 300 fathoms of 1.7/16" steel cable.

Two Derricks capable of lifting 2 tons.

Electric boat-hoisting winches, a steam windlass on the fo'c's'le, electric capstan on the quarter deck and an electric winch for the derricks.

1—5000 fathom Lucas Sounding Machine, steam driven.

1—5000 fathom Oceanographical winch, electric.

Deep Sea and normal ship echo sounding gear.

Motor boats echo-sounding and portable echo-sounding equipment.

Radar equipment similar to the Home Ships, with corner reflector topmarks for surveying beacons.

Radio Navigational aids, such as Loran or Decca etc.

Asdic gear for locating wrecks.

Taut wire measuring gear.

Oropesa sweeping gear.

The Chartroom is forward on the fo'c's'le deck, and the Dark Room nearby contains complete photographic and copying equipment.

There is a Motor Boats Workshop on the Boat Deck.

New 29 foot Surveying Motor Boat

Length : 29'0".

Beam : 8'0".

Draught : 2'11" aft, 1'3" forward.

Weight : 5 tons.

Engine : Diesel, Perkins P.6., 6 cylinder.

Horse Power : 45 H.P. 1500 R.P.M.

Fuel Capacity : 45 gallons.

Speed : 8 knots.

Hull (skin) : Two thicknesses, inner is diagonal, outer fore and aft.

Life saving capacity, about 32 men.

New 27 foot Surf Boat

Length : 27'0".

Beam : 6'4".

Draught : 1'1 1/2".

Weight : 28 cwt.

Sail Area : 210 square feet, Gunter rigged.

Hull (skin) : Double diagonal.

Life Saving Capacity, 25 men.

New 14 foot Surf Boat

Length : 14'3".

Beam : 5'0".

Draught : 0'11".

Weight : 10 cwt.

Sail Area : 70 square feet, Gunter rigged.

Hull (skin) : Double diagonal.

Life saving capacity, 8.

Outboard Engine—Anzani, 4 H.P., speed 4 1/2 knots.



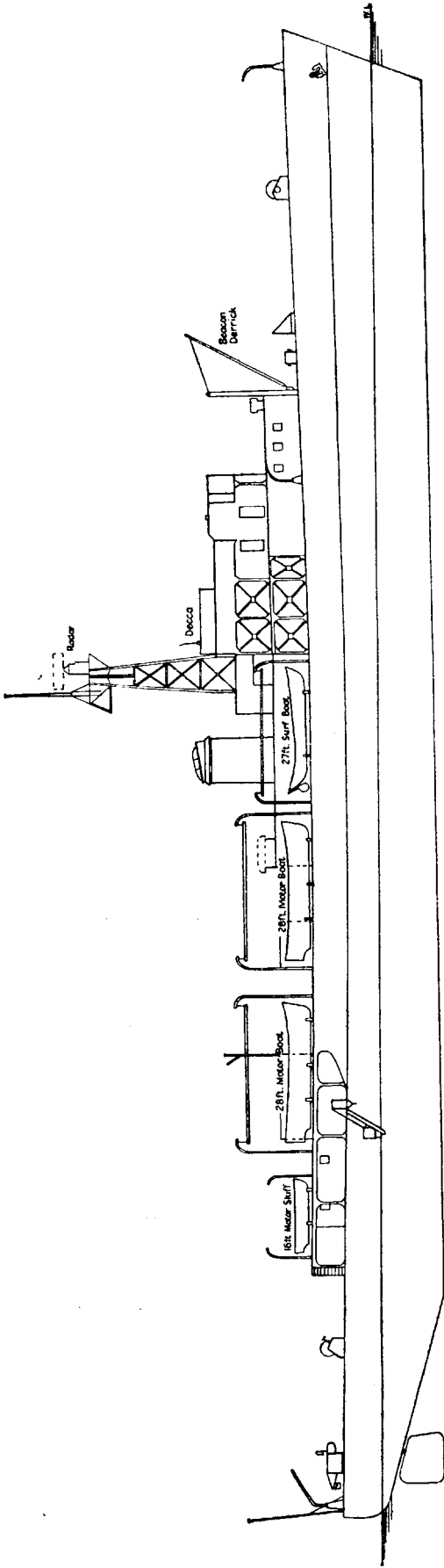

H.M. SURVEYING SHIP "DAMPIER"

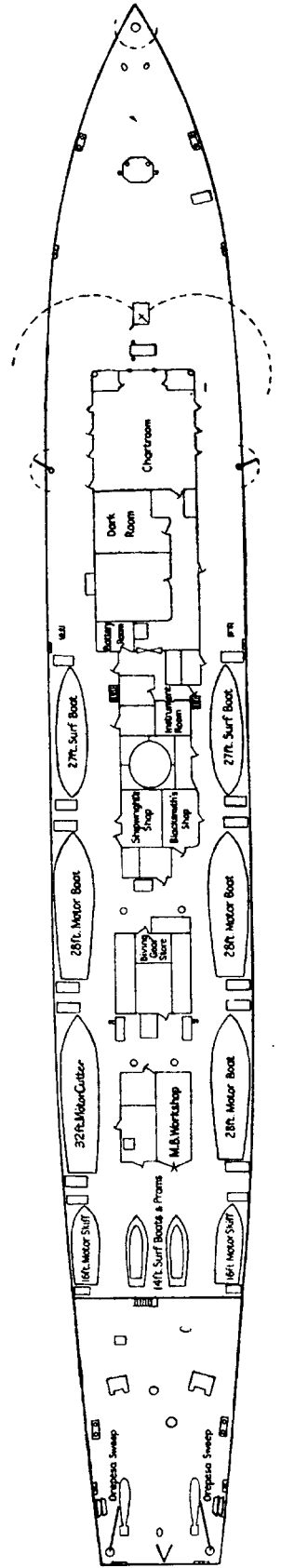

29F' SURVEY MOTOR BOAT

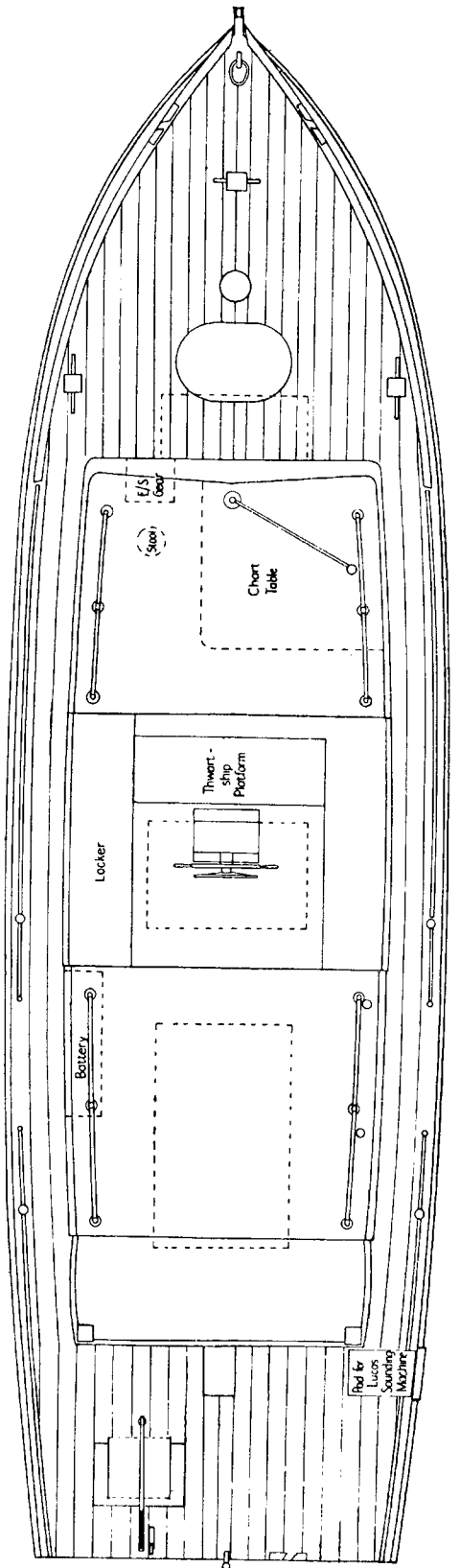
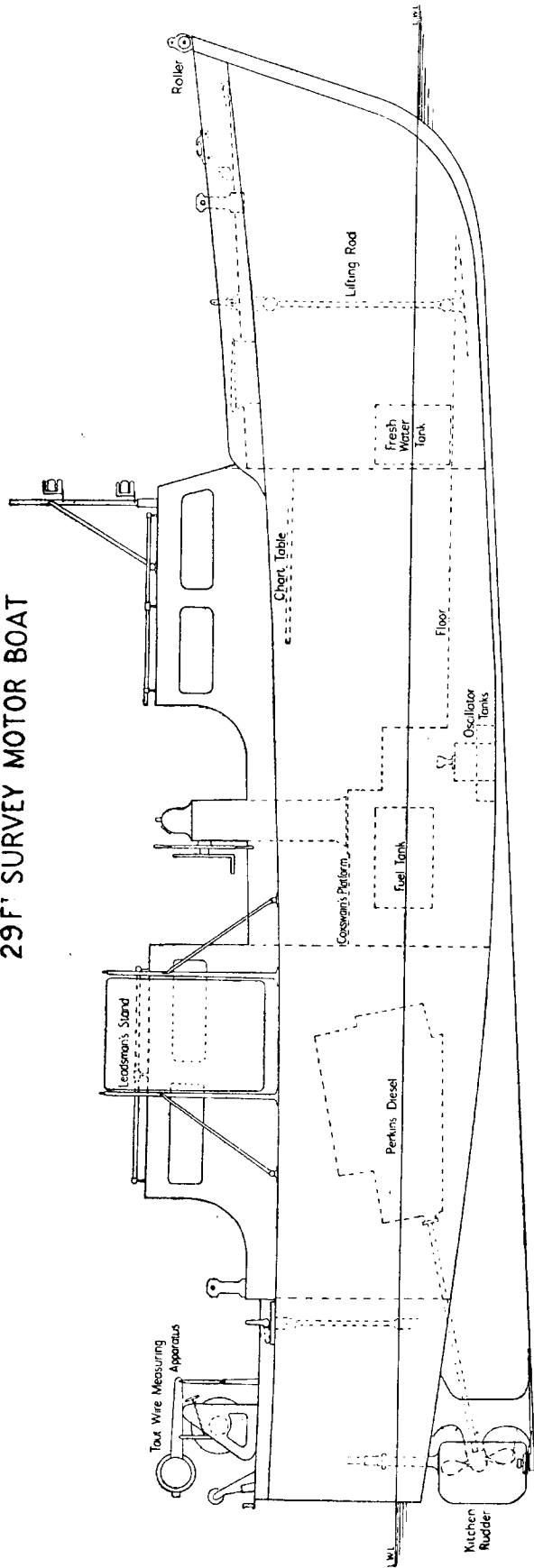

14F' SURF BOAT

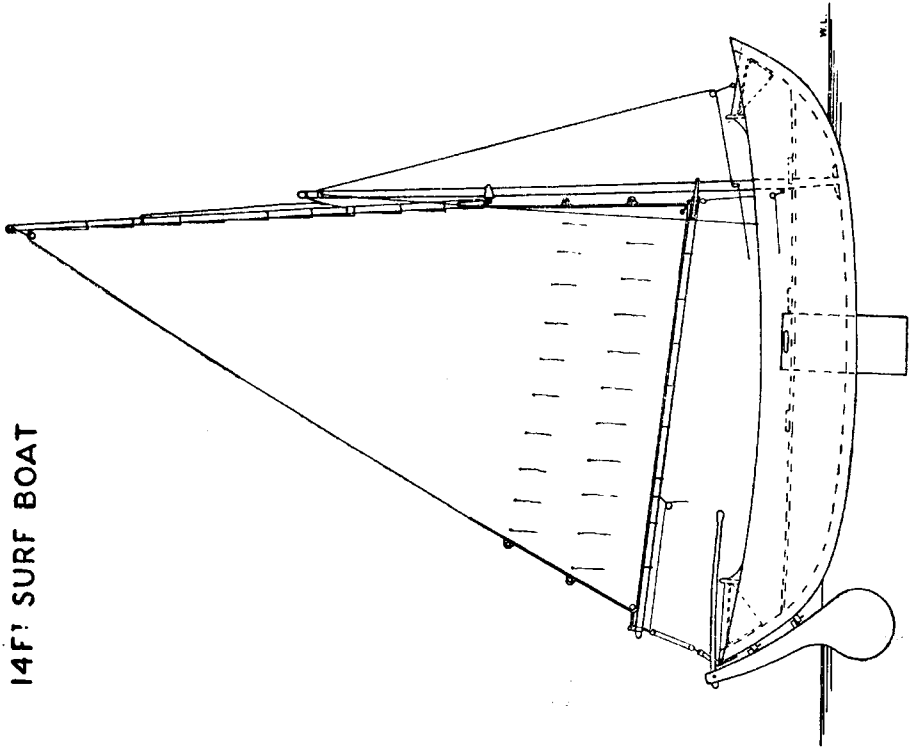

27F' SURF BOAT

