

AN INSTRUMENT FOR RECORDING CONTINUOUSLY THE SALINITY, TEMPERATURE, AND DEPTH OF SEA WATER.

by A. W. JACOBSON, Member AIEE.

(Contribution number 428 from the Woods Hole Oceanographic Institution).

Preprinted from *Transactions of the American Institute of Electrical Engineers*,
Vol. 67, New York, N. Y., 11/4/1948.

Many physical phenomena in oceanography can be determined from knowledge of the horizontal and vertical distributions of the salinity and temperature of sea water. Current practice in obtaining salinity measurements makes use of sampling devices and chemical analyses. (1, 2). Surface temperatures are measured with conventional-type thermometers and thermographs. Measurements at subsurface levels are made with reversing thermometers (1) and with mechanical "bathythermographs" (3), which provide a record of temperature as a function of depth. Although these methods provide highly accurate information, the lack of continuity of salinity data may at times limit their usefulness. Also, considerable time is consumed in the procedures of sampling, analysis, and plotting of data, and it is often difficult to retain navigation.

The instrument described measures continuously the temperature and specific electrical conductance of sea water, and computes from these its salinity. The measured temperature, the computed salinity, and the depth at which the measurements are being made are recorded simultaneously on a strip chart.

The instrument operates from a 115-volt 60-cycle supply and is unaffected by normal voltage and frequency variations or by the vibration and motion of the vessel. It measures the temperature of the water over a range from 28 to 90 degrees Fahrenheit with an error not greater than 0.2 degree Fahrenheit. Salinity is determined over a range from 20 to 40 parts per thousand (0/00) with an error not greater than 0.3 0/00. The maximum error in depth over the range from 0 to 1,200 feet is 12 feet. The time lag of the instrument is governed primarily by the thermal speed of response of the resistance thermometer bulb, which has a time constant of 0.45 second.

Although the precision is less than obtainable by standard reversing thermometers and titrations for chlorinity, this disadvantage is offset for many purposes by the convenience of continuous measurement, and the prompt availability of the temperature and salinity data.

Several earlier instruments for determining the salinity of sea water from conductivity measurements are described in the literature. (4-9) These instruments employed Wheatstone bridge circuits by which the conductivity of a batch or flowing sample of sea water was compared with that of a standard of known salinity contained in a sealed cell while both were maintained at the same temperature. While this method provided a high degree of accuracy, the use of a sealed cell for temperature compensation introduced a serious time lag, and limited the practical application of these equipments.

GENERAL DESCRIPTION.

The instrument consists of three major units; the measuring elements assembly, the computing and recording mechanisms, and the amplifier unit. The electrical connections between the units are made with multiple-conductor cables and plug-type connectors, so that no tools are necessary in hooking up the equipments. Figure 1 shows the instrument installed in the Woods Hole Oceanographic Institution research vessel *Balanus*.

The measuring elements assembly, shown partly in section in Figure 2, includes a resistance thermometer bulb, a conductivity cell, and a Bourdon pressure element. The resistance bulb has a thermal time constant of 0.45 second and is capable of with-

standing external pressures in excess of 2,000 pounds per square inch. It is constructed by drawing a number of strands of enamelled nickel wire into a long, small-diameter, thin-walled copper capillary tube, sealing the ends, and winding the tube on an open frame to form a helix. The connections are brought out through one end with kovar-glass sealed terminals. The conductivity cell is made up of a plastic tube sheathed in heavy bronze tubing and includes three coaxial platinum-lined electrodes, one in the center and one at each end. The Bourdon depth element is made of a beryllium copper alloy. Its free end carries a contact which moves across a slide-wire, converting a position measurement to an electrical value which can be easily transmitted. A single 9-conductor waterproof cable connects the measuring elements assembly to the recorder. The several sections comprising the housings for the measuring elements are bolted together, using confined rubber gaskets to make the complete unit pressure tight.

The computing and recording mechanisms are mounted on a steel frame enclosed in a wood case having removable sides and top cover. The top view of this unit is shown in Figure 3. The measuring and computing mechanisms are electromechanical servo systems. The chart drive mechanism is provided with a speed change lever which can be used to change the chart feed rate from a given number of inches per hour to the same number of inches per minute. In addition, several sets of change gears are provided to permit many different chart speeds to be obtained. The maximum speed is 12 inches per minute. The three recording pens deflect about a common axis, and each uses a characteristic color of ink for making its record. A fourth pen, fixed in position, indicates any lateral departure of the chart, making it possible to correct the readings should a departure occur. The chart has 62 uniform divisions and has printed on it three sets of scales, one for each of the required measurements. One division on the chart corresponds to the following increments; 1 degree Fahrenheit in temperature, $0.2 \text{ }^{\circ}/_{100}$ in salinity, and 20, or 10, feet in depth, depending upon the calibration of the depth measuring element. Two salinity ranges are provided; 20 to $32 \text{ }^{\circ}/_{100}$ and 28 to $40 \text{ }^{\circ}/_{100}$, a switch being used for setting the desired range.

The specific conductance of the sea water is indicated by a dial visible through a window in the front of the case.

Four identical amplifiers, housed in a single open-type case, are used to increase the power available from the measuring and computing circuits to a level sufficient for operating the various balancing motors. All of the electrical connections to each amplifier are made with a single plug-type multiple connector.

The mechanical construction of the instrument is sturdy, and it will not be damaged by reasonably rough handling. Where fixed mechanical relationships must be maintained for accurate performance, the units involved are pinned together or to supporting structural members with close-fitting dowels. All metal parts are protected from corrosion by Navy-approved methods for shipboard equipments.

In order to prevent ambient temperature errors all fixed resistors and slide-wires in the measuring and computing circuits are wound with resistance wire having a negligible temperature coefficient. To insure long satisfactory performance, all capacitors and transformers used in the instrument are sealed hermetically.

DISCUSSION OF DESIGN.

Temperature System.

The selection of a resistance thermometer for the temperature measuring element was made after considerations were given to various types of systems. These included the resistance thermometer, liquid-filled and vapor-tension type bulbs, and thermocouples. The systems were compared for accuracy, reproducibility, speed of response, scale distribution, and measuring and servo system requirements. The resistance thermometer arrangement was selected because it appeared to offer the best compromise among these factors.

Resistance thermometer bulbs can be reproduced with an accuracy of 0.1 degree Fahrenheit or better, and by suitable design the time constant can be made small, in the order of one-half second. The scale distribution, which depends upon the type of temperature-sensitive wire and the circuit used, can be made nearly linear. A simple Wheatstone bridge circuit energized from an a-c source can be used to measure the resistance of the thermometer bulb.

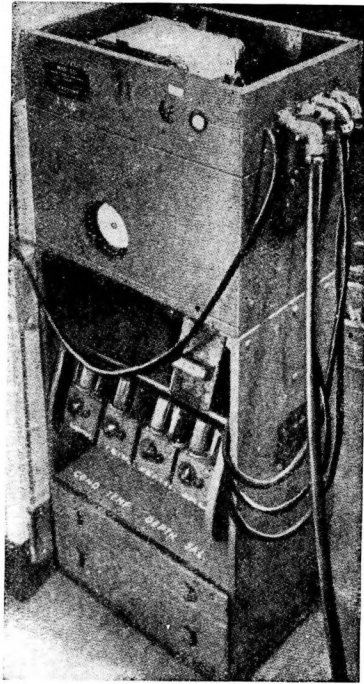

FIG. 1.

Shipboard installation of salinity-temperature-depth recorder.

Variations in the supply voltage affect only the sensitivity of measurement. A simple a-c electronic amplifier can be employed to provide the necessary output power, and the performance of the system can be made so that large variations in the contact resistance are negligible.

Conductivity System.

Laboratory measurements of the electrical conductivity of a solution are usually made with a 2-electrode cell and a Wheatstone bridge circuit. When this type of cell is immersed in a solution the measured conductance includes the conductances of the paths within and external to the cell. Since the cross-sectional area of the external shunt path may be very large for a cell submerged in the sea, its conductance will be large compared to the conductance within the cell. A cell with an electrode at each end may be effectively short-circuited when used in this way.

To avoid this difficulty a cylindrical cell with three coaxial electrodes is used. One electrode is in the center of the cell and one at each end. The two outer electrodes are connected together electrically, and the potential is applied between them and the center electrode. The lead to the center electrode is insulated, and approximately half of the current in this lead flows through the sea water sample to each end electrode. The two paths from the center electrode being in parallel, the measured conductance is the sum of the conductances of these paths. As the two outer electrodes are short-circuited together, they are at the same potential and no current will flow between them through any external shunt path. Thus, the measurements are independent of external shunt conductances and the cell constant may be determined without the need for duplicating the actual conditions of use. Moreover, this permits the use of a heavy protective metal sheath around the cylindrical cell, eliminating the possibility of shock damage to the plastic tubes which comprise the cell body.

A Wheatstone bridge circuit can be used to measure the conductance of the sea water in the cell, the bridge being energized from an a-c source.

Depth System.

The depth of a measuring element can be determined best by measuring the sea pressure at that depth. Pressure is related to depth by considering the average specific gravity of the sea water to be 1.025. Although the actual specific gravity may differ from this value because of temperature and salinity conditions, the integrated error is usually negligible.

Pressure is most simply measured with calibrated spring elements, such as Bourdon tubes or bellows arrangements. The choice between these is governed by the factors: required power output, permanence of calibration, freedom from hysteresis, mechanical simplicity, and physical size. Experience with both of these types indicated that, for the

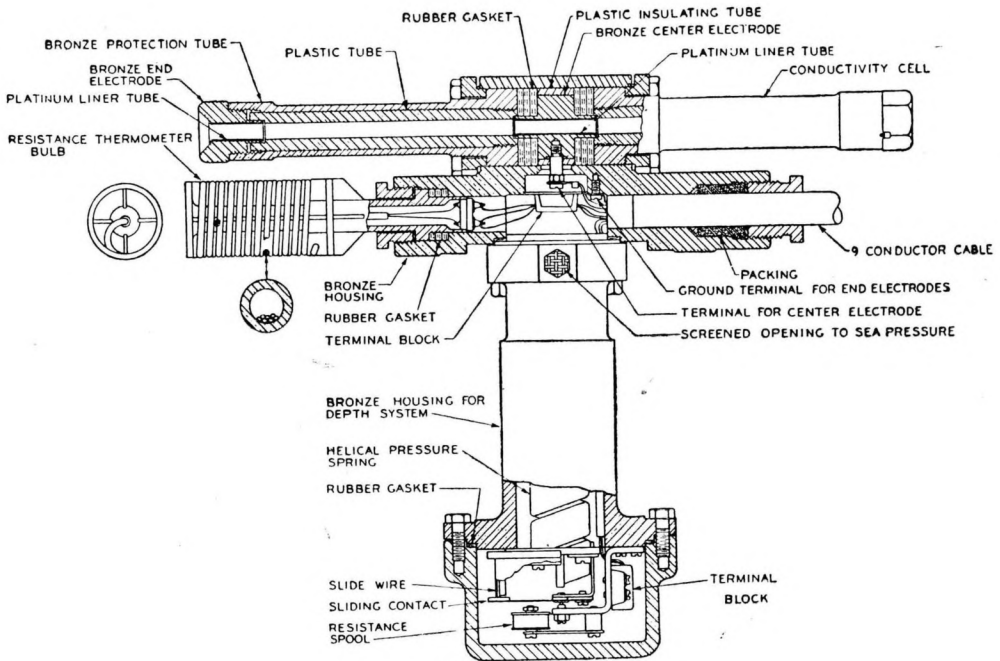

FIG. 2.

Section view, measuring elements assembly.

pressure range involved, the Bourdon helical element offered the best compromise among these factors. This type, when used to move a contact across a slide-wire, permits the use of a simple bridge circuit for measuring the pressure, together with an amplifier and servo system identical to those used for the other measurements.

Salinity Computing Circuit.

A circuit arrangement for obtaining salinity directly from simultaneous measurements of temperature and conductivity was preferred to the use of a temperature compensating cell as employed in previous instruments. (4, 5, 6, 9). The slow response of a sealed cell designed to withstand the necessary pressure makes it less useful in a hydrographic instrument.

The use of a sealed reference cell in a bridge circuit for determining salinity does not provide exact compensation even when the sample water and the water in the sealed cell are maintained at the same temperature. An examination of the errors shows them to be only slightly less than those for the computing arrangement employed in the present instrument. However, serious errors may result from the difference in temperatures of the water in the measuring and reference cells caused by the thermal lag of the reference cell. Since it was expected that a resistance ther-

meter bulb could be made with less thermal lag than a sealed cell designed for the same pressure, thus permitting the high-speed performance desired, the computing method was selected.

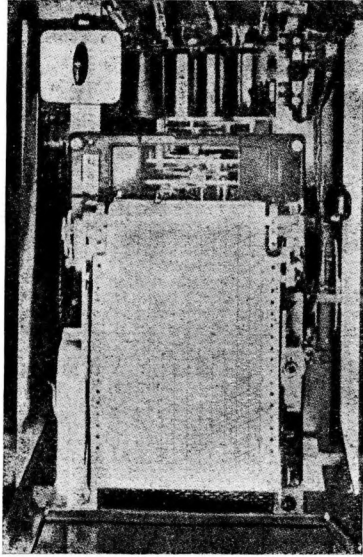

FIG. 3.

Recorder, top view.

The mathematical functions employed for the computation of salinity were derived from published data (10) relating conductivity to chlorinity and temperature. These data were translated to provide salinity as a function of conductivity and temperature by the use of the relationship

$$\text{Salinity} = 1.805 \times \text{Chlorinity} \quad (1)$$

in which chlorinity is defined as the total amount of chlorine, bromine, and iodine in grams contained in one kilogram of sea water, assuming that the bromine and iodine had been replaced by chlorine. This expression differs by $0.03 \text{ } ^\circ/\text{ } ^\circ$ from the empirical equation

$$\text{Salinity} = 0.03 + 1.805 \times \text{Chlorinity} \quad (2)$$

which was established by an International Commission (11) based on samples collected from the Baltic Sea. Since the maximum possible error arising from the use of equation 1 instead of equation 2 amounts to only $0.03 \text{ } ^\circ/\text{ } ^\circ$ and is less than the expected error of the instrument, the employment of the simpler relation is justified. Figure 4 shows the relationships between the specific conductance of sea water and the salinity for the temperature range 30 to 90 degrees Fahrenheit.

When these data are plotted with temperature as the parameter, all of the curves of the family obtained diverge from the origin, and each is slightly concave toward the salinity axis. When the logarithms of salinity are plotted against the logarithms of conductivity for each temperature value, all of the curves are approximately parallel and very nearly straight lines. If they were exactly straight and parallel, it would be possible to represent salinity precisely by the product of two independent functions; one of temperature, and the other of conductivity. By adjusting these curves so that this condition exists, an approximate function of this form is obtained. This complete

family of adjusted curves can be represented with reasonable accuracy by the empirical equation

$$S = \left(\frac{100,000}{25.661 + 0.73720 T} - 348.87 \right) c^{1.0946} \quad (3)$$

where S is the salinity in parts per thousand, T the temperature in degrees Fahrenheit, and c is the specific conductance in mhos per centimeter cube. This particular approximation was selected to give the error distribution indicated in Figure 5. It will be noted that the least errors are incurred for salinities between 30 and 35 ‰. The average salinity of the surface waters of the oceans is about 35 ‰. In coastal waters it is approximately 32 ‰. Only in some of the enclosed seas in geographical areas

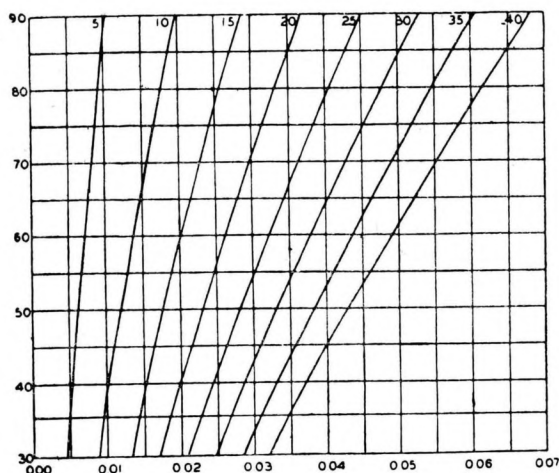

FIG. 4.

Salinity of sea water from temperature and specific conductance.

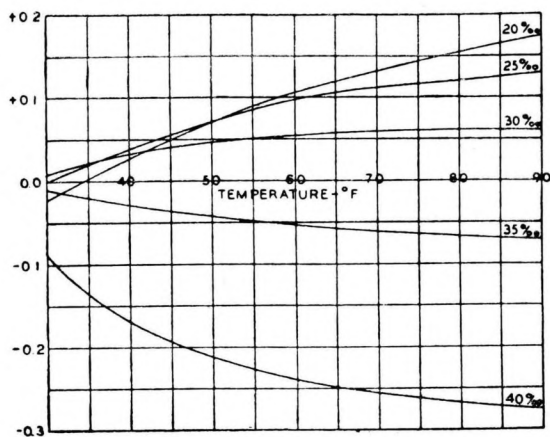

FIG. 5.

Theoretical salinity error curves.

where the evaporation exceeds the precipitation, such as the Mediterranean and Red Seas, does the salinity approach 40 ‰. Salinities less than 30 ‰ are encountered in coastal areas near river mouths and in some enclosed seas, as the Black Sea and the Baltic.

In order to perform the computation indicated by equation 3, mechanisms are required for deriving the necessary functions from independent measurements of temperature and conductivity, for multiplying these functions, and for indicating the product by the position of a pen on a chart. Although a much simpler mechanism can be employed for obtaining salinity when a sealed reference cell is used, the computing system was selected as the most practical arrangement chiefly because it makes rapid continuous measurements possible by reducing the time lag to that of the thermometer bulb.

DISCUSSION OF CIRCUITS.

Amplifiers and Servomotors.

In order to provide the power necessary to operate the computing and recording mechanisms the output of each bridge circuit must be amplified. All of the measuring and computing circuits are energized with alternating current of line frequency. The output from each bridge is supplied to an independent electronic amplifier which operates the balancing servomotor of the bridge.

Each amplifier includes a rectifier tube, three stages of resistance-coupled voltage amplification, and a power stage. The tubes are operated below normal ratings to

increase their useful life, and ordinary variations in their characteristics have no effect on the performance of the systems. The input resistance of each amplifier is approximately one-quarter megohm, and as the measuring and computing circuits are used in a null-balance manner, large changes in the resistances of the sliding contacts have only small effects on the sensitivities of the measurements. By incorporating a gain control in each amplifier the same type of amplifier serves for both the measuring and computing circuits.

The servomotor employed with each circuit is a small 2-phase induction motor, one phase being energized from the line and the other from the amplifier output. Its direction of rotation depends upon the relative phase of the amplifier output voltage with respect to the line and its speed is a function of the magnitude of this voltage. The slide-wire contacts and their associated recording pens are geared to their respective motor shafts, so that a direct relationship exists between them. The time for full-scale deflection of each of the measured and recorded quantities is approximately five seconds.

Temperature Circuit.

Figure 6 is a diagram of the Wheatstone bridge circuit used for the temperature measurement, in which R_6 represents the thermometer bulb, connected to the circuit by three leads. R_1 is a slide-wire, and R_2 , R_3 , R_4 and R_5 , are fixed resistances. Voltage is applied to the bridge from step-down transformer T_1 , and the bridge output is connected to an amplifier. When the bulb temperature changes, the resulting bridge unbalance is amplified to operate a servomotor and move the slide-wire contact to a new position of equilibrium. The position of the contact then represents the temperature at the thermometer bulb.

The calibration equation of the Wheatstone bridge circuit can be derived by setting to zero the expression for its output voltage. Designating e_1 as the voltage applied to the bridge from the transformer T_1 , P the resistance of R_1 and R_2 in parallel, L_1 the resistance of each lead wire, and x the resistance of the fraction of P between the bottom end of the slide-wire and its contact, then for balance

$$\left(\frac{e_1 - i_1 L_1}{L_1 + P + R_3 + R_4} \right) (L_1 + R_3 + x) - \left(\frac{e_1 - i_1 L_1}{R_6 + R_5 + L_1} \right) (R_6 + L_1) = 0 \quad (4)$$

where i_1 is the current in the transformer branch. Defining

$$R_6 = R_{01} + r_1 \quad (5)$$

where R_{01} is the resistance of the thermometer bulb at 28 degrees Fahrenheit and r_1 is the change in the resistance from 28 degrees Fahrenheit to the temperature measured, and by constructing the resistances so that

$$R_3 = R_{01} \quad (6)$$

and

$$P + R_4 = R_5 \quad (7)$$

equation 4 can be rearranged to give

$$x = \frac{R_5 r_1}{R_{01} + r_1 + L_1 + R_5} \quad (8)$$

As e_1 and i_1 do not appear in this equation the calibration is independent of the applied voltage.

The magnitude of the fractional error caused by a change of lead resistance can be determined from the derived equation

$$\frac{dx}{x} = \frac{dL_1}{R_{01} + r_1 + L_1 + R_5} \quad (9)$$

By making the denominator large compared to the expected dL_1 , it is possible to keep small the effects of changes in lead length on the calibration. For the circuit values used a change in lead resistance of 2.5 ohms will cause an error of only 0.1 degree Fahrenheit at full scale, and one-half this error at mid scale. This resistance corresponds to approximately 400 feet of number 18 copper wire. By calibrating the 3-lead circuit for a nominal value of lead resistance, large changes in the lead length can be tolerated.

An expression for the resistance of the thermometer bulb at temperature T is

$$R_6 = R_{01} (1 + a (T - 28) + b (T - 28)^2) \quad (10)$$

where a and b are constants for the wire material. If

$$t = T - 28 \quad (11)$$

from equations 5 and 10

$$r_1 = R_{01} (at + bt^2) \quad (12)$$

Substituting 12 in 8

$$x = \frac{R_5 R_{01} (at + bt^2)}{R_{01} (1 + at + bt^2) + L_1 + R_5} \quad (13)$$

The slope of x with respect to t is

$$\frac{dx}{dt} = \frac{R_5 R_{01} (R_{01} + L_1 + R_5) (a + 2bt)}{[R_{01} (1 + at + bt^2) + L_1 + R_5]^2} \quad (14)$$

In this equation both the numerator and denominator increase with t , and it is possible by proper selection of R_{01} and R_5 to make the slope practically constant over the full-scale range. The thermometer bulb wire in this instrument is nickel to high purity, and the bridge circuit is designed for this bulb so that the maximum departure of the calibration from a linear scale is only 0.06 degree Fahrenheit.

The measuring sensitivity of the circuit depends on the temperature coefficient of the bulb wire and the current through it. The current used, about 20 milliamperes, is sufficiently low for the bulb construction so that the temperature rise caused by the power dissipated in the winding is negligible. The bulb has a time constant of 0.45 second and consequently gives a response of 90 per cent of the change in one second.

Conductivity Circuit.

The conductivity measuring circuit, shown in Figure 7, is a Wheatstone bridge. R_{16} is the resistance of the sea water in the cell, L_2 is the resistance of each lead, and R_{13} , R_{14} , and R_{15} are fixed resistances. Transformer T_2 supplies a voltage e_2 to the bridge circuit. The amplifier and servomotor are identical to those used with the temperature measuring system. Designating Q as the resistance of R_{11} and R_{13} in parallel, and y as the resistance of the fraction of Q between the upper end of the slide-wire and its contact, then, by a treatment similar to that applied to the temperature circuit, it can be shown that

$$y = \left(\frac{Q + R_{14} + L_2}{1 + \frac{(R_{15} + L_2) c}{k}} \right) \frac{R_{15}}{k} c \quad (15)$$

where c is the specific conductance of the sea water and k is the cell constant, which are related to R_{16} by

$$k = c \times R_{16} \quad (16)$$

The circuit values are selected so that y is equal to Q when c is the full-scale value of specific conductance, c_m .

Since the denominator in equation 15 is not constant, the scale distribution is nonlinear. However, as specific conductance is not directly recorded on the linear chart, but used only for computing salinity, linearity is not necessary. The circuit values used in this instrument cause a maximum nonlinearity of less than two per cent.

As in the temperature measuring circuit, the primary element is connected to its bridge by three leads. Here also the purpose of the 3-lead connection is to keep the errors caused by a change in lead resistance to a small value. If only two leads were used, the sum of their resistances would add directly to the resistance of the sea water in the cell. For the circuit values used in the instrument, a length change of 16 feet of two number 18 wires would introduce an error of 0.1 per cent at full scale.

The bridge resistances are constructed so that

$$Q = R_{15} \tag{17}$$

and

$$R_{14} = \frac{k}{c_m} \tag{18}$$

For these relationships it can be shown, that the use of three leads instead of two for connecting the cell to the bridge circuit reduces the maximum error caused by a change in lead resistance in the approximate ratio of eight to one. With the circuit values used in the instrument, a change in lead length of about 125 feet will introduce a 0.1 per cent error.

The constant for a conductivity cell depends on its mechanical dimensions and the sizes, shapes, and surface conditions of the electrodes. Cells of similar design can be readily made having constants within two or three per cent of each other. When a cell is replaced by another having a different constant, the value of the resistance R_{15} can be changed to retain the original calibration for one particular value of specific

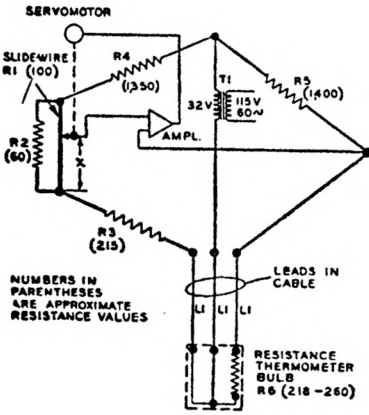

FIG. 6.
Temperature measuring circuit.

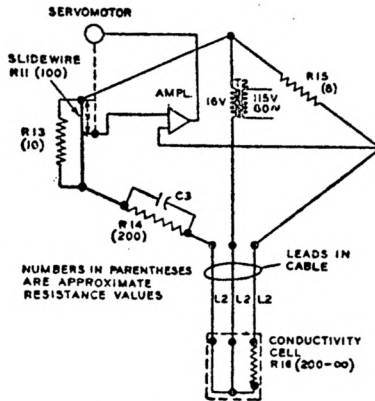

FIG. 7.
Conductivity measuring circuit.

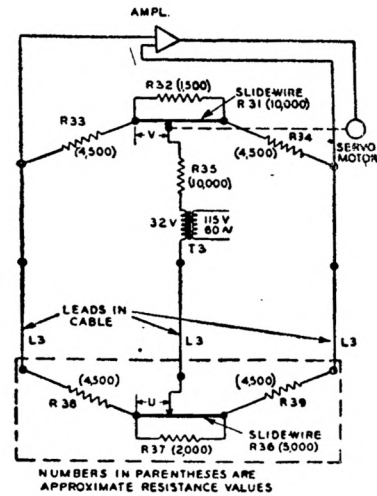

FIG. 8.
Depth measuring circuit.

conductance. For other specific conductances the calibration is altered slightly, the extent of the change depending upon the magnitude of the term $(R_{15} + L_2)/k$ in equation 15. With the circuit components used in the instrument a five per cent change in the value of the cell constant will cause only a 0.08 per cent variation in the calibration curve. Each cell has a separate R_{15} resistance spool made for it, and when cells are changed the R_{15} spools are also changed.

Another factor affecting the value of the constant of a cell is the phenomenon of polarization, which introduces uncertain errors in the measured conductance. When direct current is passed through a solution, the products of electrolysis accumulate at the electrodes and no constant value of conductance can be determined. With alternating current the ions are not discharged at the electrodes. However, there are still some polarization effects, which are attributed to variations in the ionic concentrations near the electrodes. To obtain good accuracy the effects of polarization must be kept small. This can be accomplished by using a cell with electrodes of large surface area and a large constant and by employing high a-c frequencies. A common method for increasing the effective area of an electrode is the application of a coating of platinum black to its surface. Tests made by Kohlrausch and Holburn (12) indicate that polarization is negligible for platinized electrodes when the area of the electrode in square centimeters is greater than $50 \times C$, whereas 0.1 per cent accuracy can be obtained with bright electrodes whose area is greater than $2,500 \times C$, C being the measured conductance expressed in mhos. Experiments by Thurax (4) have shown that the difference in polarization between 1,000 and 60 cycles is quite small, being in the order of 5 parts in 100,000. Because of its availability, and as it permits the use of the same type amplifier employed with the temperature circuit, 60 cycle alternating current is used for the conductivity circuit.

Another effect of polarization is to produce an apparent high capacitance in series with the conductance of the cell. The reactance of this capacitance is in quadrature with the conductance, and it does not change the measured conductance in proportion to its magnitude. However, it does affect the sensitivity of detecting the balance condition of the circuit and it becomes more important at the lower frequencies. Platinization of the electrodes increases the value of the series capacitance, making its reactance smaller. During the experimental stages of the development of this instrument it was observed that for the cell and electrode arrangement used, the ratios of the series capacitances to the conductances were approximately constant for all salinities within the working range. This ratio is the cotangent of the phase angle between the applied voltage and the resulting current. If the phase angle were exactly constant for a cell it would be possible to cancel completely the quadrature component of the circuit output by introducing the capacitor C_3 across the resistance R_{14} to shift the phase of the current in the balancing branch of the circuit an equal amount. This capacitance is determined from the relation

$$C_3 = \frac{\tan N}{2 \pi f R_{14}} \quad (19)$$

where N is the phase angle of the cell and f is the frequency. By applying a capacitor in this manner the need for platinum-black coatings on the electrodes was avoided.

Depth Measuring Circuit.

The depth measuring circuit, shown in Figure 8, is a double slide-wire bridge. R_{36} is the slide-wire in the transmitting unit, the contact of which is positioned by the free end of a helical pressure spring. R_{37} , R_{38} , and R_{39} are fixed resistances in the transmitter. R_{31} is the slide-wire in the recorder, whose contact is actuated by a servomotor and mechanically connected to the depth recording pen. R_{32} , R_{33} , R_{34} , and R_{35} are fixed resistances in the recorder. The resistance of each lead is indicated by L_3 . Transformer T_3 applies a voltage e_3 to the bridge, and the amplifier unit amplifies any unbalance and causes the servomotor to move the recorder contact to restore a condition of balance. In a conventional bridge of this type the amplifier is normally connected between the two sliding contacts, rather than as shown in Figure 8. With a high-input impedance amplifier this arrangement has the advantages of providing uniform sensitivity over the scale range and being unaffected by large changes in the contact resistances. However, as the lead to the transmitter contact is in the long cable connecting the measuring elements assembly to the recorder, it is subject to inductive effects from the currents and voltages of the adjacent leads connecting to other circuit elements. These can directly introduce errors in depth measurements, depending upon the amplitude and relative phase of the resultant pickup. To avoid this possibility of error, the voltage supply is connected between the two sliding contacts. Here, the same degree of pickup in the cable lead has a negligible effect because of the relatively large measuring current flowing in it. This is consistent with the connections of the temperature and conductivity circuits, where the amplifier input leads which are sensitive to pickup are

all in the on-board equipments, and can be kept short and be properly shielded. This arrangement has the disadvantage of causing variable measuring sensitivity over the depth scale and less protection against variations in the contact resistances. However, by making the resistance of R₃₅ high, and the effective resistance of the slide-wires low, in relation to the resistances on each side of the slide-wires, these disadvantages become negligible. By doing this there is considerable attenuation of the useful power, but as the total power supplied to the bridge is small this is not a serious matter.

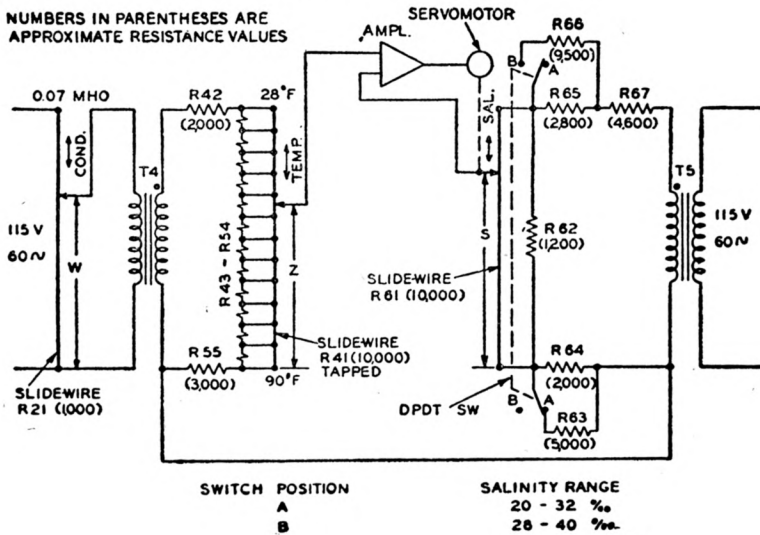

FIG. 9.

Salinity Computing Circuit.

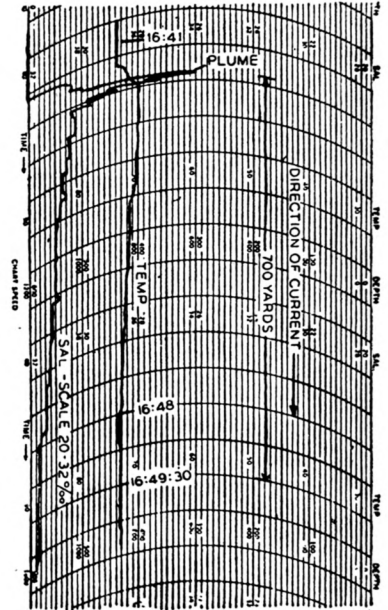

FIG. 10.

Surface recording in vicinity of sewer outfall at New Bedford, Mass.

Designating the parallel resistance of R₃₁ and R₃₂ by M, the parallel resistance of R₃₆ and R₃₇ by N, with v and u representing the fractions of M and N respectively, from the left-hand end of each slide-wire to its contact, and by constructing the resistances so that

$$M = N \tag{20}$$

and

$$R_{33} = R_{34} = R_{38} = R_{39} \tag{21}$$

then the contact position at balance is given by

$$v = \frac{(2R_{33} + M) u + ML_3}{2(R_{33} + L_3) + M} \tag{22}$$

For this circuit arrangement, the maximum error caused by a change in lead resistance can be shown to be represented by

$$\frac{dv}{M} = \frac{dL_3}{2R_{33} + M} \tag{23}$$

Thus, by making the denominator large, the effects of changes in the lead resistance will be small. In the instrument this value is 10,000 ohms, so that a 1-ohm change

in lead resistance (160 feet of number 18 wire) will cause a maximum error of only .001 per cent.

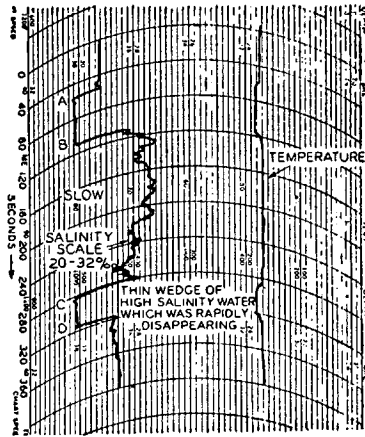

FIG. 11.

Surface recording in Mount Hope Bay.

The depth elements for the different ranges are made interchangeable by setting the fixed resistances associated with each element in accordance with the relations indicated in equations 20 and 21.

Salinity Computing Circuit.

Figure 9 is a diagram of the circuit used for computing salinity from the simultaneous measurements of conductivity and temperature. Slide-wire R21 is connected across the line, and its movable contact is positioned from the shaft of the conductivity unit according to a specific function of conductivity. The current in the temperature compensating slide-wire R41, connected to the secondary of transformer T4, is proportional to this same function, and its contact is positioned by the shaft of the temperature unit. The output voltage of R41 is, therefore, proportional to the product of the conductivity and temperature functions. The current in slide-wire R61 is supplied by transformer T5, the primary of which is connected to the power line. The transformers are used only to isolate the computing circuits from the line, each transformer having unity voltage ratio. When the voltage is zero between the contacts on slide-wires R41 and R61 the position of the contact on R61 represents the product of the conductivity and temperature functions given in equation 3, which is the salinity. Any change in this product causes an output voltage, which is amplified, and operates the servomotor to move the R61 contact to a new position of equilibrium. R42 through R55 and R62 through R67 are fixed resistances. The switch associated with slide-wire R61 serves to set the range of the salinity circuit. For the switch position shown the range is 20 to 32 ‰. The amplifier and servomotor are identical to those used with the other measuring systems.

Designating the resistance of R41 paralleled by the series resistances R43 through R54 by H, and the parallel resistance of R61 and R62 by J, with w, z, and s representing the effective variable resistances, as shown in Figure 10, then it can be shown that the amplifier input is zero when the three contact positions, w, z, and s, are related so that

$$s = \left(R_{67} + R_{65} + J + \frac{R_{63} R_{64}}{R_{63} + R_{64}} \right) \times \left(\frac{w}{R_{21} (R_{42} + H + R_{55}) + w (R_{21} - w)} \right) (R_{55} + z) - \frac{R_{63} R_{64}}{R_{63} + R_{64}} \tag{24}$$

As voltage does not appear in equation 24 the balance position is unaffected by variations in the supply. This equation for s can be expressed in simplified form by

$$s = Af_1(w) f_2(z) - B_1 \quad (25)$$

Where f indicates the functions of the respective variables and A and B_1 are constants. The function of w includes the loading effect of the temperature-compensating circuit on slide-wire R_{21} , but does not consider the added load of the exciting current of transformer T_4 . This load, which is kept low by using a transformer with a large number of turns, is taken into account in the initial calibration of the instrument.

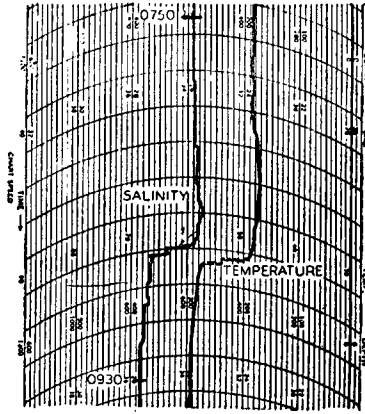

FIG. 12.

Surface traverse across edge of Gulf Stream.

The contact of slide-wire R_{21} is positioned according to the required function of specific conductance and modified for the loading effects by means of a cam associated with the output shaft of the conductivity unit. The contact on slide-wire R_{41} is moved directly by the output shaft of the temperature unit, and its position is linearly related to temperature. The required function of temperature is obtained by using the proper distribution of effective resistance in the slide-wire. This is accomplished by tapping the linear slide-wire winding at several points and shunting each section separately with a fixed resistance. This method approximates the continuous curve by a series of straight-line sections, the approximation becoming better as more sections are employed. In the instrument 12 sections are used in slide-wire R_{41} , which together with the associated shunting resistances, R_{43} through R_{54} , provide an approximation with a maximum error of 0.05 per cent.

Large changes in the resistances of the contacts on slide-wires R_{41} and R_{61} are negligible, as they are in series with the high resistance input of the amplifier. A change in the resistance of the contact on slide-wire R_{21} , however, will affect the accuracy of the computation because it alters the voltage applied to transformer T_4 . The error resulting from this condition can be minimized by making the equivalent impedance of the transformer and its load large compared to the resistance of R_{21} . No difficulty has been encountered in practice with this arrangement.

The first step in the design of the computing circuit is the selection of a conversion factor relating salinity units to resistance or voltage units. Although this selection is made arbitrarily, the choice of the factor is restricted by consideration of circuit output sensitivity, applied voltage, and the physical properties of the slide-wires. The factor used in the instrument is 80 ohms per part per thousand of salinity.

The salinity range of the chart is determined by the position of the double-pole double-throw switch. Thus, for the position shown, the B_1 constant in equation 25 is equivalent to 20 ‰. When the switch is in the high-range position,

$$B_1 = R_{43} \quad (26)$$

which is equivalent to $28^{\circ}/_{00}$. The A constant is then

$$A = R_{87} + \frac{R_{65} R_{66}}{R_{65} + R_{66}} + J + R_{64}. \quad (27)$$

The resistances are proportioned so that

$$R_{65} + \frac{R_{63} R_{64}}{R_{63} + R_{64}} = \frac{R_{65} R_{66}}{R_{65} + R_{66}} + R_{64}. \quad (28)$$

Thus, the constant A has the same value for both switch positions, maintaining the same current through slide-wire R61 for each of the salinity ranges.

The parallel arrangement of resistances is used so that the switch contacts will be in series with the high resistance shunts, thus making negligible the effects of varying switch contact resistances.

Use at Sea.

Several of the salinity-temperature-depth recorders have been made and are being used regularly at sea. An earlier model, which recorded salinity and temperature only, has been in use for nearly three years. These instruments have proved to be well adapted to securing continuous measurements from a moving vessel. For determining surface water conditions, the measuring elements assembly may be mounted on the hull below the water line, where the conductivity cell is irrigated by the boat's motion, or inboard in which case it is irrigated by a stream of water maintained with a pump. When used on a small boat, where the intake is within a few feet of the surface, air bubbles are frequently drawn into the circulation and cause undesirable fluctuations in the salinity record. This difficulty did not appear when the measuring elements assembly was installed on an intake line of the research vessel Atlantis which was located 12 feet below the water line. On small boats it may be overcome by mounting the intake tube on a strut which holds it about one foot away from the hull at a depth of two or three feet.

Figures 10 and 11 are illustrations which show how strikingly the instrument records sudden changes in the temperature and salinity of the surface water. In Figure 10 a record is shown taken from a boat which passed directly over the outfall of the sewer at New Bedford, Mass., in the direction in which the tide was flowing. Note the sharp discontinuity encountered upstream of the outfall, the great drop in salinity as the plume was crossed and the gradual increase in salinity which occurred over a distance of 700 yards downstream. Figure 11 shows a sharp discontinuity in salinity encountered in Mount Hope Bay where a tongue of more saline water had become surrounded by dilute water flowing from the Taunton River. The boat entered the saline water at A, crossed into more dilute water at B, turned and re-entered the tongue at C and emerged from it at D.

Figure 12 shows a record of the temperature and salinity at a depth of three and one half feet made in a 10-mile traverse across the inshore margin of the Gulf Stream.

Figures 13 and 14 show records of vertical measurements through temperature and salinity gradients. The depth transmitting element used for these surveys was calibrated to give full-scale deflection of the depth recording pen for 300 feet. The true depths are obtained from the records by dividing by two the readings on the 0-600 scale. These records indicate clearly the usefulness of the instrument for obtaining the hydrography of complicated water structures. It can be noted from Figure 13 that the temperature and salinity are reasonably constant from the surface to a depth of 50 feet, indicating a well-mixed layer. From 50 to 200 feet both the temperature and salinity undergo large changes, but the gradients are not uniform. Below 200 feet both quantities are reasonably constant. The considerable wiggle in the depth trace was caused by the rolling of the vessel. Note how the magnitude of the wiggle is reduced with increasing depth, as the sag in the lengthening cable absorbs the vertical motion of the boat.

Figure 14 shows the very sharp salinity gradient in the estuary of the Thames River at New London, Conn. A shallow layer of fresh water from the river overlays the more saline water from the Long Island Sound. From both the large positive

salinity gradient and the negative temperature gradient it is evident that a large positive density gradient exists, indicating a very stable water column with little tendency for vertical mixing.

Experience has indicated the need for taking certain precautions in using the instrument. It was anticipated that serious errors in the measurements of conductivity might result from fouling of the cell with bacterial slime or macro-organisms. A cell has been operated under the wharf at Woods Hole for weeks at a time. Under these conditions the cell constant slowly changes, causing a salinity error of as much as $0.5 \text{ } ^\circ/_{100}$. Under active

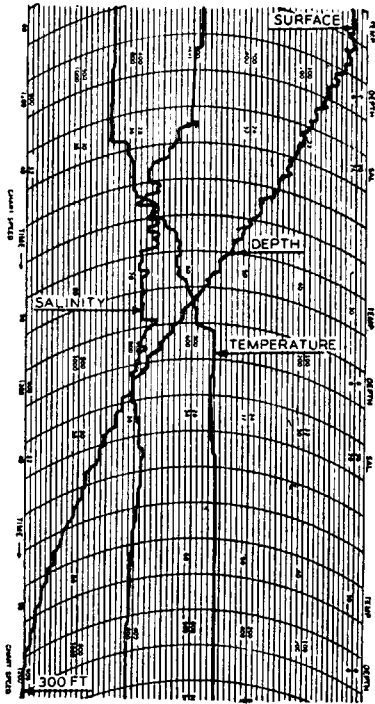

FIG. 13.

Vertical recording in ocean water.

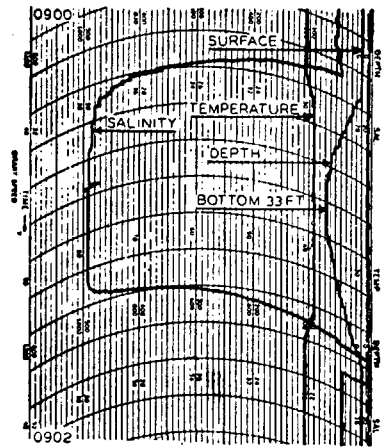

FIG. 14.

Vertical recording in Thames River Estuary at New London, Conn.

use during surveys difficulties due to fouling have not arisen, but it is clear that the measuring elements should not be mounted permanently where they are inaccessible to cleaning or are subject to fouling over prolonged periods. Some difficulties caused by inadequate flushing of the conductivity cell have been encountered in vertical surveys, making it necessary to exercise care in controlling the rate of descent of the measuring elements. Further study is being given the cell design with the object of improving its flow characteristic. Improved accuracy over limited ranges of the measured quantities can be obtained by taking calibration samples of water within the ranges and applying fixed corrections to the records.

CONCLUSIONS.

A practical salinity and temperature recording instrument is described. This type of instrument has been operated regularly for more than three years and has been found useful for obtaining hydrographic data. It has been applied particularly for inshore surveys in shoal water and in ocean areas where its accuracy of 0.2 degree Fahrenheit and $0.3 \text{ } ^\circ/_{100}$ is adequate. Its time constant of one-half second permits continuous records of temperature and salinity to be made from a moving vessel, or while the measuring elements are being lowered vertically.

REFERENCES.

- (1) The Oceans, H. U. Sverdrup, M. W. Johnson, R. H. Fleming. Prentice-Hall, Inc., New York, N. Y., 1942, pages 347-57.
- (2) The determination of chlorinity by the Knudsen Method. The Woods Hole Oceanographic Institution, Woods Hole, Mass., 1946.
- (3) A Bathythermograph, A. F. Spilhaus. *Journal of Marine Research* (New Haven, Conn.), volume 1, 1938 pages 95-100.
- (4) An Electrical Instrument for recording sea water salinity. E. E. Weibel, A. L. Thurax. *Journal of the Washington Academy of Sciences*, Washington, D. C., volume 8, 1918, pages 145-53.
- (5) An Electrical Instrument for recording sea water salinity. A. L. Thurax. *Journal of the Washington Academy of Sciences*, Washington, D. C., Volume 8, 1918, pages 676-87.
- (6) Apparatus for the determination aboard ship of the Salinity of sea water by the Electrical conductivity method. F. Wenner, E. H. Smith, F. M. Soule. *Journal of Research*, National Bureau of Standards (Washington, D. C.), volume 5, 1930, pages 711-32.
- (7) Thermo-Electric Apparatus for Temperature Measurement in Limnological Research, P. Ullyott, O. Ilgaz, F. Konuk. *Faculté des Sciences*, Istanbul University, Istanbul, Turkey, Volume 7, 1942, pages 23-40.
- (8) Apparatus and Methods for measuring the Conductivity of Natural Waters in Marine and Semi-Marine conditions. P. Ullyott, O. Ilgaz. *Faculté des Sciences*, Istanbul University, Istanbul, Turkey, volume 7, 1942, pages 190-227.
- (9) The Salinometer Model XI. Hin Lew. *Report Number PS 251*, National Defense Council of Canada, Division of Physics and Electrical Engineering, September 15, 1945.
- (10) The Electrical conductivity of Sea water. T. D. Thomas, T. G. Thompson, C. L. Utterback. *Journal du Conseil, Conseil Permanent International pour l'Exploration de la Mer* (Copenhagen, Denmark), volumes 9, 1934, pages 28-35.
- (11) Berichte Über die Konstantenbestimmungen zur Aufstellung der Hydrographischen Tabellen. C. Forch, M. Knudsen, S. P. L. Sorenson. Kongelige Danske Videnskabernes Selskab, Skrifter, 6 Raekke, Naturvidenskabelig og mathematisk Afdeling (Copenhagen, Denmark), volume XII, number 1, 1902.
- (12) Das Leitvermogen der Electrolyte. F. W. G. Kohlrausch, L. Holborn. Berlin, Germany, 1916.

