

ON THE EFFICIENCY OF ACOUSTIC WAVES IN ECHO SOUNDINGS OF FISH SHOALS

by Dr. Heinz M. GABLER,

German Hydrographic Institute, Hamburg, Germany.

In recent years the application of echo-sounding methods to fishing practice has steadily increased in importance (1). The successful employment of Electronic Fish Finders has enabled the average duration of a fishing expedition to be reduced from 25 to 15 days, and even with this 40 % reduction the catch has usually been twice as large. An explanation may be of general interest, therefore, as to particular claims put forward on behalf of echo-sounders in connection with fishing, modifications that arise in comparison with sounders hitherto known, and as to existing limits of efficiency in the present state of development of technical instruments.

In order that definite acoustic echoes may be received from shoals of fish at all, transmission of acoustic waves must be *directional*. Yet an effective concentration of acoustic waves with periodically excited acoustic transmitters and receivers can only be obtained within the range of ultra-sonic frequencies. In the generating of such ultra-sonic waves, magnetostrictive excitation proved to be a considerable improvement over the prior application of piezoelectrical excitation. Magnetostrictive excitation is particularly suited to the generation of acoustic echoes in water, as on account of the high acoustic resistance only small amplitudes of oscillation as against a relatively large mechanical driving power are required. As is well known, the effect of magnetostriction in ferromagnetic materials, discovered by Joule (2), denotes the mechanical changes of dimensions occurring during magnetization. Analogically, by the reciprocal Joule effect is understood the change in the magnetic condition of a ferromagnetic material combined with mechanical deformations. The changes in the length of ferro-magnetic materials generated by magnetization are independent of the direction of the magnetic field. Consequently a ferro-magnetic material placed in an alternating magnetic field will be stimulated to longitudinal oscillations with twice the frequency of the alternating field. Nickel is best suited as a material for magnetostriction transmitters and receivers, as it shows a relatively large Joule effect, even at small magnetic field intensities, and good magnetic characteristics. It handles easily, and is highly resistant to sea-water corrosion. As material for the oscillators, packets of separately insulated thin plates of nickel are used for the effective lowering of any losses in eddy currents. The magnetic resistance is reduced by setting up closed magnetic circuits in order to maintain the highest possible degree of efficiency. The nickel packets have punched holes, which take up the exciter winding of the oscillator, consisting of a few lengths of rubber-insulated wire. A rubber pad insulates the nickel packet acoustically from the oscillator case. Magnetostrictive transmitters are usually square in shape, and are directly connected with the water by means of a rectangular radiant plane of some 8 to 15 square centimeters. Their excitation may either be effected periodically by means of an electric valve generator or aperiodically by discharge of a condenser circuit. In the first case the oscillator makes undamped forced oscillations, and in the second case damped natural oscillations, which after a few periods practically fade away. This method of excitation has the advantage of great simplicity, and therefore is the most usual in sounding work. Both methods of excitation, as mentioned above, make it necessary to operate with a frequency

of alternating current corresponding to *half* the mechanical natural frequency of the oscillators. As 30 kilocycles per second are chosen for the frequency of the oscillator, electrical excitation must therefore occur at 15 kilocycles per second.

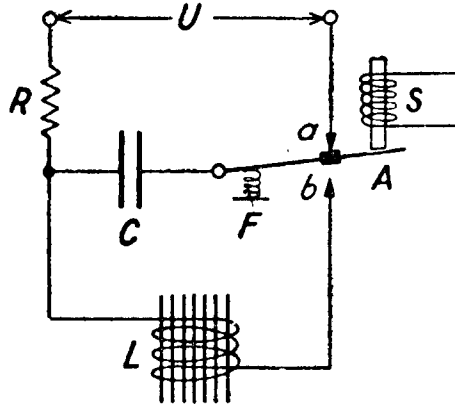

FIG. 1.
Wiring of a pulse circuit generator of a magnetostrictive echo sounder.

Fig. 1 shows the approved wiring of a pulse circuit condenser : an alternating voltage is transformed into a high voltage of approximately 1500 volts and then is rectified. The direct voltage U thus produced charges a condenser $C = 10^{-6}$ Farad across a resistor $R = 2,5 \cdot 10^{-4}$ Ohm (Ω). The charging is done as follows : a stationary current of a relay coil S connects relay armature A with stationary contact a , and thus closes the circuit, which consists of voltage supply, resistance and condenser. In the transmission of each acoustic impulse the stationary current of the relay coil is interrupted momentarily. For this purpose spring F places the armature of the relay in relation with contact maker b , thus effecting a discharge of the condenser across the magnetostriction oscillator L , and excites the latter to acoustic transmission in its natural frequency of 30 kc/s. The oscillation circuit, consisting of condenser C and transmitter coil L , is tuned electrically to its nominal frequency of 15 kc/s. This is adequate for a self-induction coefficient of the transmitter coil of $L = 1,13 \cdot 10^{-4}$ Henry, and a reactive resistance (reactance) $\omega L = 10,6 \Omega$. As shown in Fig. 2, there are *oscillatory* discharges from the condenser across the magnetostriction oscillator. The temporal intensity of current has been registered by cathode ray oscillograph. One full cycle of the damped oscillation corresponds to a time $T = 1/15\ 000$ sec. From the values of amplitude obtained a mean logarithmic decrement $\theta = 1,13$ will be received according to the definite equation

$$\theta = \ln \delta = \ln \frac{A_1}{A_2} = \ln \left(e^{-m \cdot \frac{2\pi}{\omega}} \right) = m \cdot T. \tag{1}$$

As the value of the decrement for the electrical oscillation circuit is

$$\theta = \pi \cdot R \sqrt{\frac{C}{L}} \tag{2}$$

with the given data the resulting active resistance of the magnetostrictive oscillator will be calculated as $R = 3,8 \Omega$.

In order to examine the natural oscillation of this quasi-stationary circuit of capacity, self-induction and resistance all connected in series, we assume that no external voltage is effective on the circuit. Therefore, the instantaneous values of voltages in self-induction coil, resistance and condenser must always be in balance. Their vector sum in any case is zero. In consequence, the generated compensating current or free current J_f complies with the differential equation

$$\frac{d^2 J_f}{dt^2} + \frac{R}{L} \cdot \frac{d J_f}{dt} + \frac{1}{LC} \cdot J_f = 0 \quad (3)$$

As $J_f = \frac{dQ_f}{dt}$ an analogous differential equation results for the free charge Q_f of the condenser.

With regard to boundary conditions for the oscillatory discharge of a condenser at time $t = 0$, the solutions of these differential equations for free charge and free current respectively are :

$$Q_f = e^{-\alpha t} \cdot \frac{U_c}{\beta} \cdot \sqrt{\frac{C}{L}} \cdot \sin \left(\beta t + \text{arc tg } \frac{\beta}{\alpha} \right) \quad (4)$$

$$J_f = e^{-\alpha t} \cdot \frac{U_c}{\beta L} \sin \beta t \quad (5)$$

with

$$\alpha = \frac{R}{2L}; \quad \beta = \sqrt{\frac{1}{LC} - \left(\frac{R}{2L}\right)^2} \quad (6)$$

The condition for maximum current being

$$\frac{d \left(e^{-\alpha t} \cdot \sin \beta t \right)}{dt} = 0, \quad (7)$$

the following highest value for free current results :

$$J_{f \max} = U_c \sqrt{\frac{C}{L}} \cdot e^{-\frac{R}{2L\beta} \cdot \text{arc tg } \frac{\beta}{\alpha}} \quad (8)$$

As numerical value we then get $J_{f \max} = 109,6$ Amperes. The maximum of current is reached after time $t = \frac{1}{\beta} \cdot \text{arc tg } \frac{\beta}{\alpha} = 0,221$ T, i. e. after approximately 1/68 000 sec.

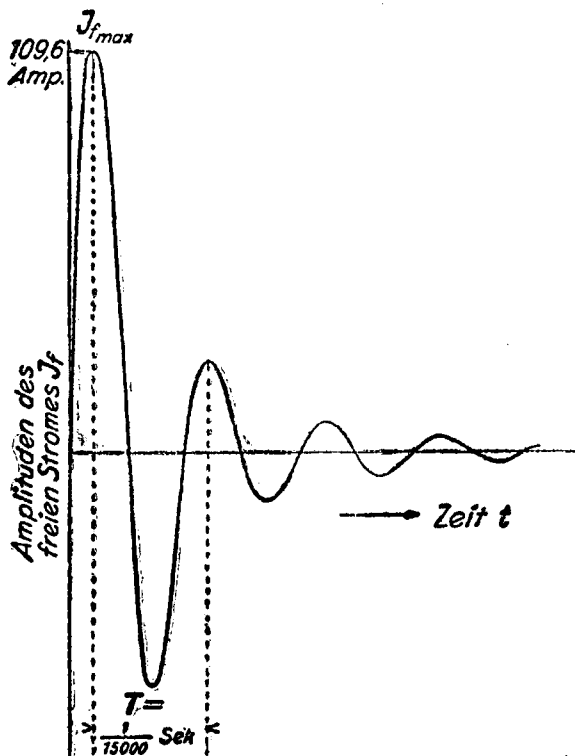

FIG. 2.
Oscillogram of a 15 Kc/s current pulse in the coil of a magnetostrictive transmitter.

The oscillogram of Fig. 2 shows that practically the whole energy of the pulse circuit condenser is fed to the oscillator after four cycles. If the mean quadratic value of currents is composed over all of the eight half cycles, then the real power taken up from the magnetostriction coil during discharge of the condenser is calculated with regard to the dimensions of ordinates in the oscillogram of Fig. 2 as :

$$J^2R = (32,5)^2 \cdot 3,8 = 4 \text{ kilowatts.}$$

The oscillator takes up this power only for a time $4 T = 2,66 \cdot 10^{-4}$ sec. Any sounding pulse transmitted by the oscillator contains eight acoustic waves. As an acoustic electric efficiency of 50 % can be obtained, the acoustic energy transmitted to the water from the magnetostriction oscillator while impulses are being produced is about 2 kilowatts.

The acoustic oscillations arriving as echoes on the acoustic receiver excite the nickel unit of the oscillator to mechanical oscillations, causing, owing to the reciprocal Joule effect, periodic changes in its magnetic condition. Consequently an electric alternating voltage is induced in the windings surrounding the nickel plates. This exceedingly low voltage is amplified up to a maximum of 80 000 times by means of a tuned-in amplifier. Fig. 3 shows the oscillogram of voltage supplied from a magnetostrictive oscillator at the amplifier exit; greatest amplitude is reached after 12 oscillations, that is, at $t = 4 \cdot 10^{-4}$ sec. In general, depths up to 600 metres may safely be sounded with magnetostriction

sounders. With the use of superheterodyne reception, echo soundings up to a maximum depth of 4 000 metres could even be received (3).

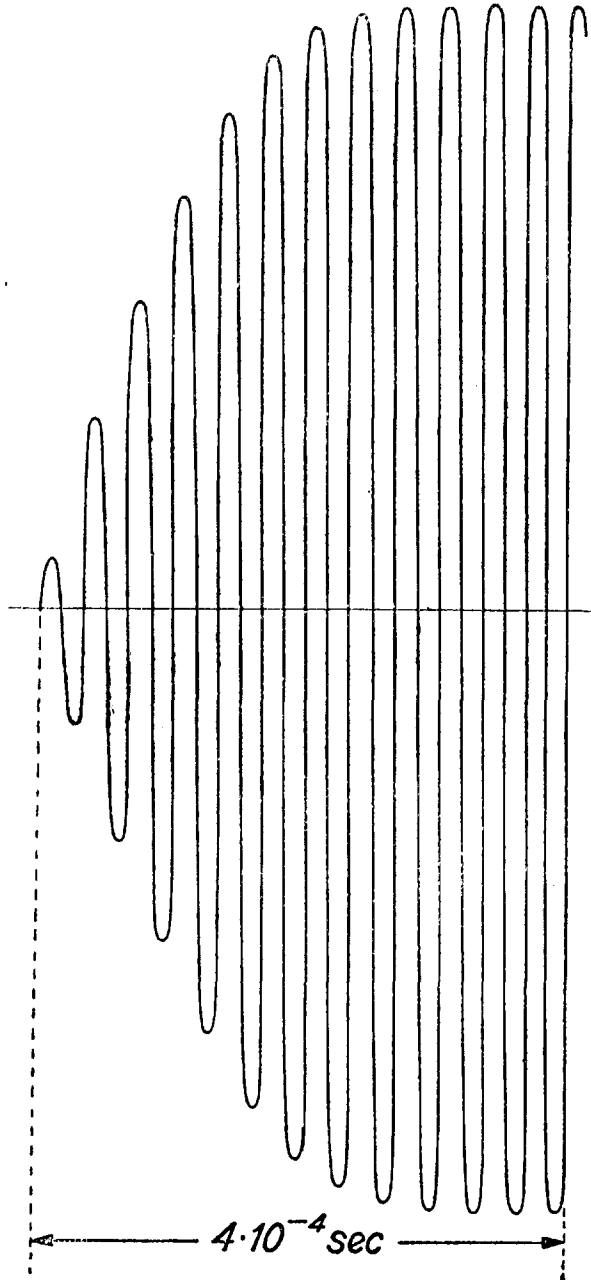

FIG. 3.

Voltage oscillogram of an echo registered at the amplifier exit of a magnetostrictive receiver.

The acoustic waves, with a frequency $f = 30$ kc/s generated by the magnetostriction oscillator, are transmitted through the water with a propagation speed of $c = 1\,500$ m/sec. Their wavelength is therefore $\lambda = 5$ cm. As the 8

to 15-square-centimetre radiant plane of the oscillator is large as compared with the wavelength, acoustic transmission is not undirectional but concentrated. In general, the smaller the wavelength becomes in relation to the dimensions of the oscillator, the more distinct becomes the generated directional effect. With respect to a rectangular piston membrane, the directional factor F characterizing the intensity of concentration is termed

$$F = \frac{\sin\left(\frac{a\pi}{\lambda} \cdot \cos \alpha\right) \cdot \sin\left(\frac{b\pi}{\lambda} \cdot \cos \beta\right)}{\frac{a\pi}{\lambda} \cdot \cos \alpha \cdot \frac{b\pi}{\lambda} \cdot \cos \beta} \tag{9}$$

a and b are the dimensions of the oscillator, as shown in Fig. 4, λ is the acoustic wavelength, α and β the directional angles for a convenient line of direction to P in the rectangular system of coordinates x, y, z . It can be easily proved that the directional factor reaches its highest value ($F = 1$) when the line to P coincides with axis Z . Then

$$F = \frac{u}{v} = \frac{u''}{v''} = \frac{2 AB \cdot (\cos^2 \alpha - \sin^2 \alpha)}{2 AB \cdot (\cos^2 \alpha - \sin^2 \alpha)} = 1 \tag{10}$$

$\lim \alpha = \beta \rightarrow 90^\circ$

with the abbreviations :

$$A = \frac{a\pi}{\lambda} \quad ; \quad B = \frac{b\pi}{\lambda}$$

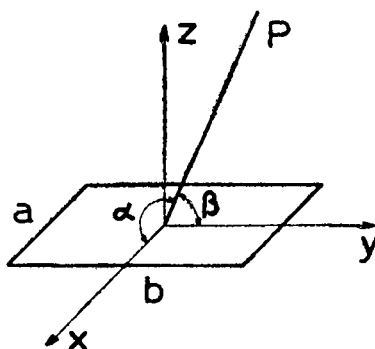

FIG. 4.
Rectangular piston membrane.

The sounder beam-width of half-value of maximum is a measure for the intensity of concentration, that is the angle formed by the membrane normal and a straight line, at which the acoustic energy has dropped to half its maximum value, and the acoustic amplitude, therefore, to the value $\frac{1}{\sqrt{2}}$.

The oscillator plane of the rectangular acoustic membrane, used for our acoustic transmitter (Fig. 4), is expressed in wavelengths $1,6 \lambda$ to $3,0 \lambda$. The directional characteristics of this plane are shown in Fig. 5. The magnetostriction receivers, being of the same construction, therefore have the same directional characteristics. Since in obtaining indications from the sounder, transmitter as well as receiver characteristics are involved, characteristics will result that

must be represented in each azimuth with respect to the oscillator normal by the product of transmitter and receiver curves. It is therefore only necessary to multiply each of the characteristics of Fig. 5 by itself to obtain the characteristics, shown in Fig. 6, resulting from the joint action of transmitter and receiver. Their beam-widths of half-value of maximum are 15 degrees and 9 degrees respectively. What consequences this involves for acoustic reception will be examined later on.

In taking echo soundings of fish-shoals, visual indicators such as glow-lamps on the receiver side are not sufficient. With them, of course, the time-incidence of echoes, that is the true depth, may be indicated very

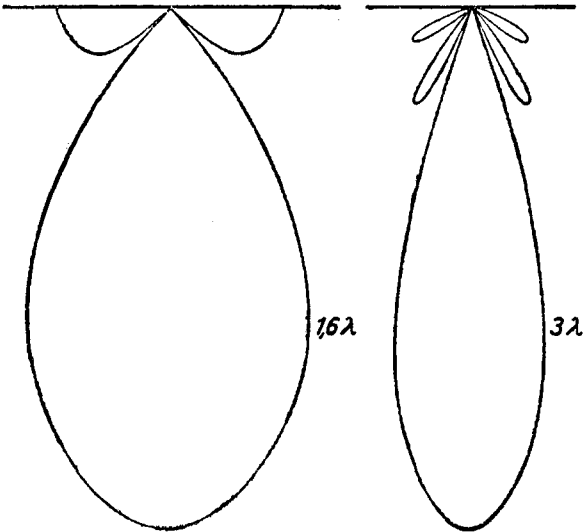

FIG. 5.

Directional characteristics of a magnetostrictive oscillator, 8 to 15 square centimetres for 30Kc.

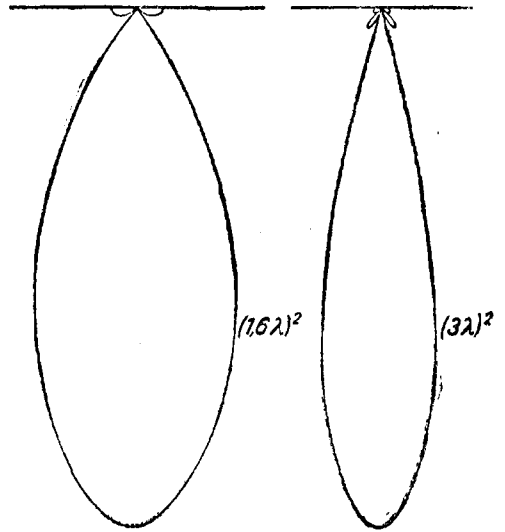

FIG. 6.

Resulting directional characteristics of transmitter and receiver oscillator of a magnetostrictive echo sounder system for 30 Kc.

accurately, yet quantitative statements as to the form, that is the duration in time of echoes, cannot be made. In order to indicate the latter, recording by means of electric sparks is a particularly appropriate procedure. This graphical recording of depths by means of conductive graphite paper is far superior to all recording methods that have so far been popular, such as ink-recorders, wax-recorders, and electrolytic paper. The arm of the spark-recorder, which rotates above the graphite paper, carries the stylus. Plotting is done on a *straight* scale, and not, as formerly done, on a curved scale (4). This greatly facilitates reading and evaluation of echo-charts.

The physical aspect of the process of echo-recording remains to be examined, as well as the consequences in connection with the evaluation of echo-charts. In opposition to the lengths of light-waves, which are smaller at least for a factor 10^{-4} than extensions in length of reflecting planes, wavelengths of ultra-sonic waves in water are frequently of the same order of magnitude. It follows that not only may geometrical conditions of reflection be expected from acoustic waves, but that in general only quasi-optical relations exist. Thus, the sea-bottom responds to acoustic waves in irregular reverberations. Part of the reflections that occur are diffused in the same manner as the irregular reflection of light-waves from the well-known "cats'-eyes" used on automobiles.

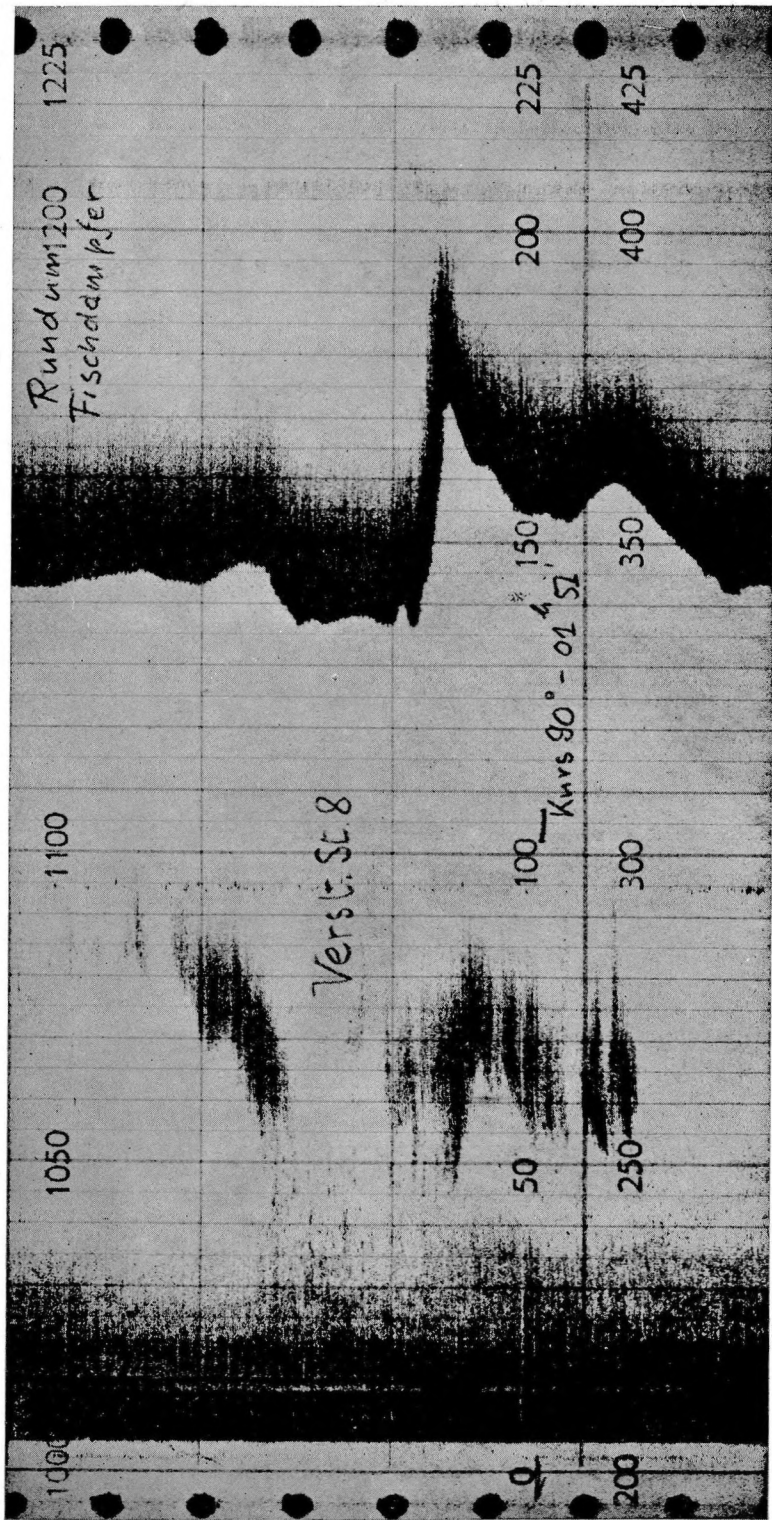

FIG. 7.

Profile of depths and shoals of fish (Position of ship: 0° 30' W, 59° 10' N.)

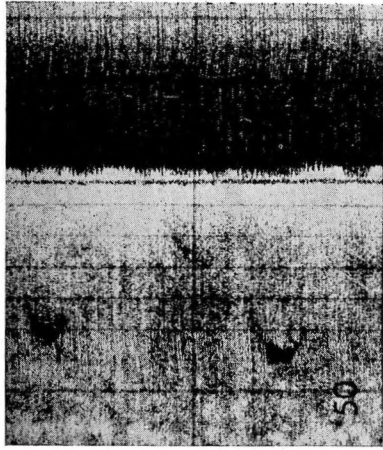

FIG. 8.

Profile of depths and shoals of fish (Position of ship : $2^{\circ} 10' E$, $56^{\circ} 40' N$.)

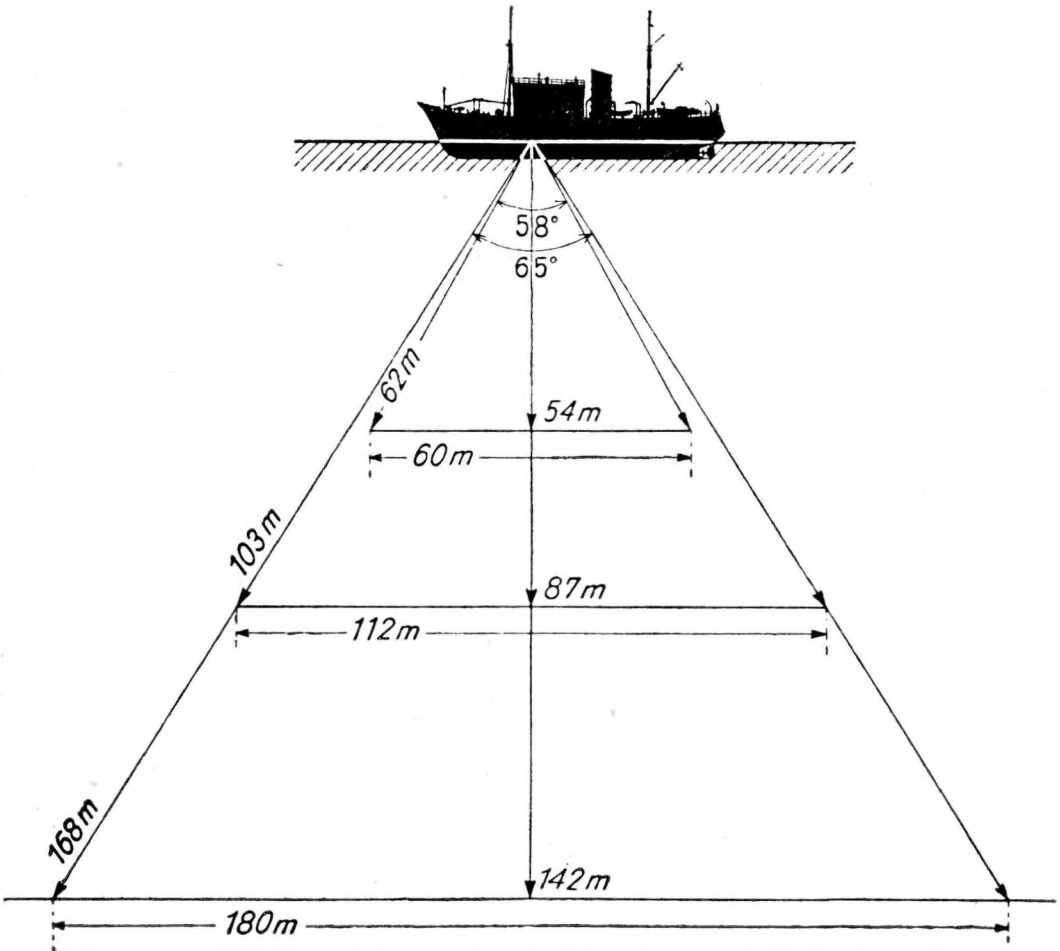

FIG. 9.

For analysis of echo charts (Figs. 7 & 8).

We shall now analyze two typical echo charts (*). The requisite dates are first given. The registration speed giving the rate of time (abscissa) is 5 millimetres per minute. The corresponding spacing of two vertical lines is 5 minutes. The time-interval of the record is read from left to right. The range of depths (ordinate), valid for both echo-charts (Figs. 7 and 8), extends from 0 to 225 metres; The quantity of sounding pulses in this range is 1,25 pulses per second. The amplifier stage used (the highest) is equal to a linear amplification of voltage about 80 000 times.

The lower section of Fig. 7 indicates the bottom profile. The depths should be read on the upper edge of the profile. For instance a depth of 142 metres is read off on the right edge of the recording band. This value, registered in Fig. 9, is the shortest sounding distance from the ship, that is, the true depth. Fig. 7 shows that because of the extremely high receiver amplification a cone of acoustic waves prevails far in excess of half the value of maximum beam-width of the oscillator. Its aperture extends as far as 65° , since the edge beams of the oscillator characteristic (Fig. 9) are about 168 metres in length (as recorded). We shall call the difference $168\text{ m} - 142\text{ m} = 26\text{ m}$ the "echo length". Although the sounding pulse sent out by the transmitter-oscillator contains only *eight* acoustic waves, the receiver-oscillator in tune with the acoustic wavelength does not produce eight but 1 048 natural oscillations, or 131 times the number of transmitted oscillations, *on account of the effective echo length in the above case.* The quantity mentioned above may be calculated without difficulty from the time-lag between an echo of the edge-beam and an echo of the central beam of the directional characteristic. During 20 minutes, or 1200 seconds — the time of the sounding record of the section shown in Fig. 7 — 1 500 sounding echoes were obtained. Acoustic reflections of fish-shoals were plotted in the upper section. Their extension is considerable. The largest group extends over some 5 minutes' recording time, which is equivalent to a length of approximately 1 550 metres at a ship's speed of 10 knots = 5,14 m/s; the recording was obtained with 375 sounder pulses. *No statement based upon these records can be made, of course, concerning the extension of fish-shoals as to depth.* Because of the quasi-optical relations of reflections, the reading off of depth limit values in relation to dark areas and the consequent assumption that: "The extension in depth in this case is 20 to 30 metres" cannot be admitted. The echo-chart in Fig. 8 confirms the correctness of this assertion.

The sounding record in Fig. 8 indicates a true depth of 87 m. Fig. 9 shows a recording of the same depth. The edge-beams recorded in this case reach a length of about 103 m., corresponding to a 65-degree aperture in the effective acoustic-wave cone. The ship's speed, however, is one-tenth that in Fig. 7, that is, 1 knot = 0,51 m/s: the ship is drifting. Over a distance of one metre travelled, therefore, there are ten times more echo pulses, that is, 2,4 echo pulses instead of 0,24 pulses as before. This increase provides a considerably improved "solution" of recordings in an optical sense, just as an objective with a great focal distance supplies a better solution than one having a small focal distance, that is, it is able to produce a greater number of scanning elements per surface unit from an object. The crescent-shaped figures in the upper portion of the pattern are also fish-shoals, but this time the ship is steaming slowly above them. Why the sickle-shaped figures? Fig. 9 supplies the answer. The true depth of the shoal of fish at the left is 54 m. Some time earlier or later than the central part, the extreme borders of the shoal are also detected with sufficient accuracy owing to the intensity of the edge of the

(*) The sounding records were obtained by Mr. F. SCHÜLKE, Scientific Member of the German Hydrographic Institute, Hamburg, in the Fladengrund area (North Sea), with an Atlas 30-kilocycle Recording Sounder during a research trip of the Research and Survey Vessel "Gauss" in August 1950.

oscillator-beam, as a ten times more detailed solution clearly confirms. Therefore sounding distances extend up to 62 m. In the previous case the fish-shoal extended up to at least 60 m. The effective aperture of the cone of acoustic waves is around 58 degrees. The 7-degree decrease is comprehensible, since reflection conditions from fish-shoals, on account of their lack of homogeneity, may not be as favourable as from the bottom of the sea.

From the above considerations, it is physically evident that, because of the quasi-optical relations of acoustic wave reflections, no comment can be made, based on echo-recordings, as to the extension in depth of shoals of fish within the range of originating echo-length. No wrong conclusions therefore, as has happened, should be drawn from the many erroneous statements as to the supposed extension in depth of fish-shoals given in the latest articles. In Publication No. 4 of "Fishery Investigations", for example, an interesting report was published on "Echo Sounding and the Pelagic Fisheries" (5), and with regard to the discussion on recorded fish-shoals we read: "It is a record of a large concentration of pilchards extending from about 18 feet below the surface to the bottom at 80 feet" (Fig. 1c),... "Fig. 16 is a chart showing small shoals of mackerel swimming at a depth of between 20 and 40 feet", and with regard to Fig. 18: "It is a large shoal which extends in depth from the surface to at least 80 feet". These "extensions in depth" should not be considered as real, as only "echo lengths" were recorded. We also find similar remarks in "Fischereiwelt", as (6): "In the morning and evening they (the herring) were distinctly higher (7 to 25 m) than in the daytime (15 to 50 m)",... "At that time fishing was being done in that area with the drift-net, that is, at a depth of from 5 to 14 m. The nets only partly reached down to the depths where the herring gathered. Considering the echo-sounding records, a better catch could have been expected with sunk nets". Furthermore Fig. 2 is described as an "Echo Chart of a compact fish-shoal 2.5 to 25 metres in depth". Mention should also be made of the "bands" caused by herring "rising from the bottom", as referred to in Figure 1, A, B of the report (7). That is to say, in the case of these quotations, that likewise only "echo lengths" were being recorded. Only the true depths of fish-shoals and recorded distances in length are real from a physical point of view. To enable the making of correct statements as to the extension in depth of fish-shoals, the d/λ relation of the oscillator would have to be considerably increased, which means that by using still higher ultra-sonic frequencies a considerably more powerful directional beam could be obtained. The question of course remains as to whether acoustic waves (even of a much stronger beam) may enter dense shoals of fish at all, and whether they can be reflected strongly enough from the lower parts. The answer would be of great general interest, and of particular concern to fishing circles.

BIBLIOGRAPHY.

1. Electronic Fish Finder, Science News Letter (July 30, 1949).
2. J. P. JOULE On the Effects of Magnetism upon the Dimensions of Iron and Steel Bars, Phil. Mag., 3, 30, 76 and 225, 1847.
3. H. GABLER..... Das Hochperioden-Überlagerungslot, ein Universallot hoher Empfindlichkeit, (*A High-Periodic Sounder of Great Sensitivity*), Deutsche-Hydrographische Zeitschrift, 2, 242-245, 1949.

4. Atlas-Echolot-Duotype, Atlas-Werke Aktiengesellschaft, Bremen, Germany.
5. WILLIAM C. HODGSON... Echo Sounding and the Pelagic Fisheries, Fishery Investigations, Series II, Vol. XVII, No. 4, pp. 1-25, London : H. M. Stationery Office, 1950.
6. W. SCHNAKENBECK Ergebnisse der Versuche mit dem Echolot zur Feststellung von Fischschwärmen. (*Results of echo-sounding research in the location of fish-shoals*), "Fischereiwelt", 2, 9-11, 1950.
7. K. SCHUBERT..... Fischlotungen (Fish Soundings), "Fischereiwelt", 2, 151-152, 1950.

