

USE OF RAYDIST TYPE "ER" IN SURVEY OF NORTH BAR OF AMAZON RIVER

by Lt. Commander Julio GONZALEZ FERNANDEZ, Brazilian Navy.

In this country, it is the Navy, acting through the agency of its specialized establishment, the Hydrographic Office, which must carry out the various operations required in drawing up nautical charts. By means of specialized personnel and equipment, this Office assumes the responsibility and financing of the various necessary activities, from planning, triangulation and sounding operations, to chart reproduction and maintenance, and the installation of aids to navigation.

The Hydrographic Office has established a regular surveying programme based on navigational requirements, but it is occasionally called upon to perform additional duties in the national interest. In this second group may be classed the survey of the Northern Branch of the Amazon River between Macapa and the Atlantic: Manganese had been discovered in the Territory of Amapa, and its only transportation outlet was by sea.

The Survey Ship *Rio Branco* was accordingly fitted out in 1952 to begin surveying operations in this area, an assignment that was destined to last for eleven months. The personnel had to resort to a unique combination of standard methods with such on-the-spot improvisation as the area required, as for example the installation of observation stations in trees. The assignment was completed in 1953, and resulted in the issuance of charts 202, 203, 204, 205 and 206 covering the area, including the navigable channel from the port of Santana, located downstream from Macapa, to Bailique Lighthouse, 110 miles out into the Atlantic.

To connect the Atlantic with this area, a further chart was required (No. 201) showing the channel into the bar.

For this purpose the *Rio Branco*, after a much needed period of overhauling, returned to Macapa in 1954, in order to continue the survey by visual methods. It was soon discovered, however, that such methods could not be used in sounding far from shore, which was low-lying and uniformly covered with high trees, and consequently offered no adequate control points for sounding purposes. On one occasion, when the use of marker buoys was inadvisable owing to the presence of a strong current of approximately 6 knots, an attempt was made to use three craft at anchor, with their positions connected to points ashore. This method however, in addition to being uneconomical, did not supply expected results, and cannot be recommended owing to the large number of shoals in the area. Commanding officers had often found themselves in difficulties on this account, since pilots were also unacquainted with the area. One of the ships nearly ran ashore in a locality where no one could come to its rescue, and was only saved by pure chance.

In the meantime, Lt. Commander Maximiano Fonseca, who had headed the 1952 survey, had gone to the United States to study the electronic position-fixing

systems best adapted to this type of operation. He decided that the Raydist « ER » system was the most convenient for the following reasons:

- (a) Only two fixed stations are used;
- (b) The station equipment is easily transportable;
- (c) The boat-sheets can easily be plotted.

The Brazilian Navy consequently acquired a Raydist Type « ER », Model I unit. This was delivered by the Hastings Instrument Co. in April 1955, and sounding operations were thereupon resumed on the North Bar of the Amazon.

Brief Description. Raydist Type « ER » is the result of the study and refinement of the older hyperbolic systems; it uses two fixed stations and one mobile station, simultaneously fixing the position of the ship on a circle of distance centred on one of the stations (the circular station) and on a branch of a hyperbola having as its foci the circular and hyperbolic stations.

The system enables replacing the hyperbola by a second circle centred on the hyperbolic station, in such a way that the ship's position is obtained by the intersections of distance-circles centred on the two fixed stations.

The position lines are determined electronically, by using the method of phase-comparison of signals read off on two phasemeters located at the mobile station.

The transition from the hyperbolic part to a distance centred on the hyperbolic station is accomplished by computing:

$$R_2 = R_1 + B - 2H$$

where R_1 is the reading of the circular part indicated by the corresponding phasemeter; it is the distance coefficient to this station;

B is the number of half wavelengths contained in the baseline or in the distance between the two fixed stations;

H is the reading shown by the phasemeter of the hyperbolic part;

R_2 is the distance coefficient with respect to the hyperbolic station.

The distance coefficient is defined as the value which multiplied by the « lane » supplies the distance of the ship to the station under consideration, « lane » being the name given to half the length of the wave used for transmission at the Master station, which in the present instance at a frequency of 4,127 kc/s supplied a value of 36.306 metres.

Plotting is carried out by means of an Odyssey plotter computed in terms of the scale of the sounding-sheet, this operation being rapidly completed.

Raydist requires calibration before sounding is begun, as in the case of all electronic position-fixing systems operating on the phase-comparison method. This operation consists in adjusting the phasemeters to the values corresponding to an accurate position determined by other means.

The equipment can operate perfectly under average weather conditions, and even during storms attended by lightning; it can be used daily for more than twelve hours. This period is limited, however, by night effect, which generally prevails between sunset and sunrise, although its occurrence and duration cannot be predicted.

Operation of « ER » system, Model I (Figure 1). The system consists of three stations, two of which are fixed and placed at the corners of a triangulation or at points connected thereto, and are therefore located in determined positions.

As mentioned above, these stations are known as the circular and hyperbolic stations. The former is the station whose distance coefficient is indicated by the phasemeter, and the latter the station whose distance must be determined by a brief mathematical operation (Figure 1).

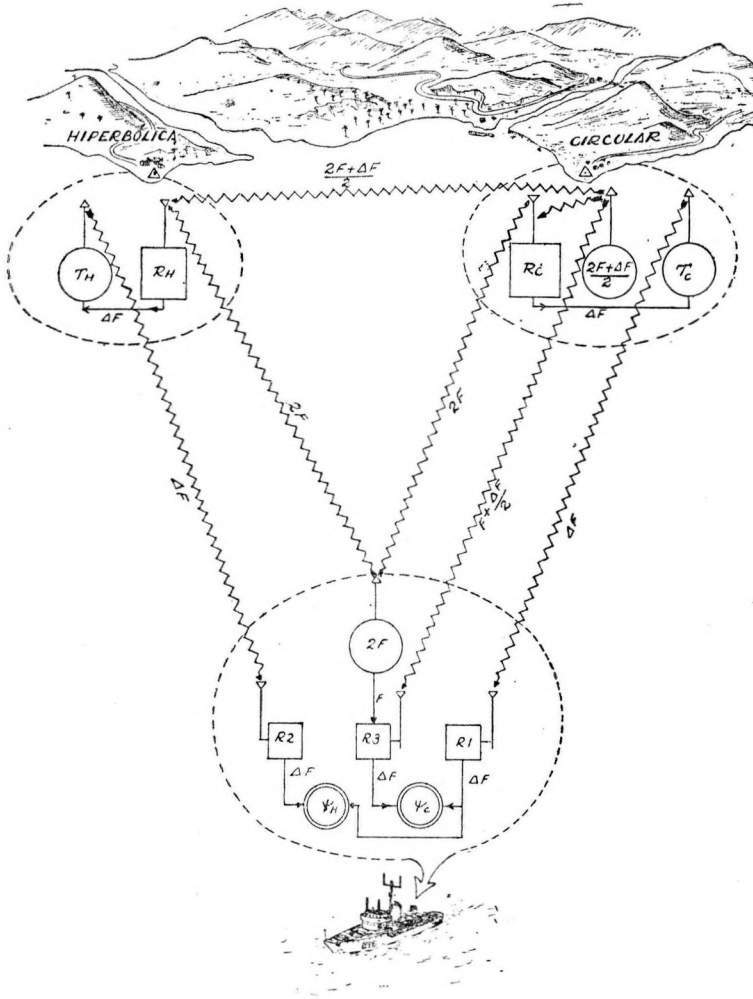

Fig. 1.

Two continuous-wave signals are used in the system :

- $2F$ (4,127 kc/s) from the mobile station and
- $2F + \Delta F$ (2,063.7 kc/s) from the circular station.

2

Two modulated-frequency signals are also used :

- Tc (32.7 Mc/s) from the circular station and
- Th (34.74 Mc/s) from the hyperbolic station.

The amplitude-modulated receiver Rc at the circular station is reached by signal $2F$ from the mobile station and a part of the second harmonic of the continuous-

wave signal from the former station itself, and thus on a frequency $2F + \Delta F$; at the output of the receiver a beat ΔF is obtained on a frequency of 400 c/s which modulates the frequency-modulated transmitter Tc.

At the hyperbolic station, two signals reach receiver Rh: signal $2F$ from the mobile station and signal $\frac{2F + \Delta F}{2}$ from the circular station; this receiver is so designed as to supply likewise a 400-cycle ΔF beat which modulates the frequency-modulated transmitter Th located at the hyperbolic station.

At the mobile station, a continuous-wave signal arrives at receiver R3 on a frequency of $\frac{2F + \Delta F}{2}$ from the circular station, as well as a $\Delta - F$ wave derived from the $2F$ continuous transmitter before its doubling stage; the receiver is designed to supply a resulting $\Delta - F$ beat of 40 cms.

At the mobile station also, a 400-cycle signal reaches receiver R1 from circular station Tc, and a frequency-modulated Th signal reaches receiver R2 from the hyperbolic station carrying the 400 cps signal received at this station.

Thus at the Master station, which is an integral part of the mobile station, three 400-cycle beats are obtained whose phases depend upon the distances between the three stations; after being suitably processed they are applied to the phasemeters in which the phase difference is measured, and where the necessary information is acquired for the fix.

Phase measurement. Phase measurement occurs in the phasemeters shown in Figure 2. No. 1, on the left, is the one normally used for the circular part, and No. 2, on the right, for the hyperbolic part.

A block-diagram of the phase-measuring system is shown in Figure 3, in which the three receivers at the Master station, i.e. Nos. 1 (circular), 2 (hyperbolic) and 3 (shipborne), supply at their outlets 400-cycle signals which are applied to their respective constant output amplifiers (COA).

On the indicators (Figures 2 and 3), switches S1 and S2 of No. 1 phasemeter, and S3, S4 of No. 2 phasemeter select the signals to be compared and send them to the phasemeters where they are processed in order to enable the corresponding phasemeter to supply the phase-measurement reading.

The positions of the switches indicate the selected receiver number; thus on No. 1 phasemeter the switches are in positions 1 and 3, showing that comparison occurs between the circular and shipborne receivers; on No. 2 phasemeter, when the switches are in positions 1 and 2, the circular and hyperbolic station receivers are being compared, giving the hyperbolic part of the system.

Mathematical demonstration. The « ER » Raydist system consists of three stations, two of which are fixed and are termed the « circular » (C) and « hyperbolic » (H) stations, and the other mobile, called the « Master » (M) station, and which is located on the ship or craft used in sounding operations. Each station is equipped with transmitters and receivers as required.

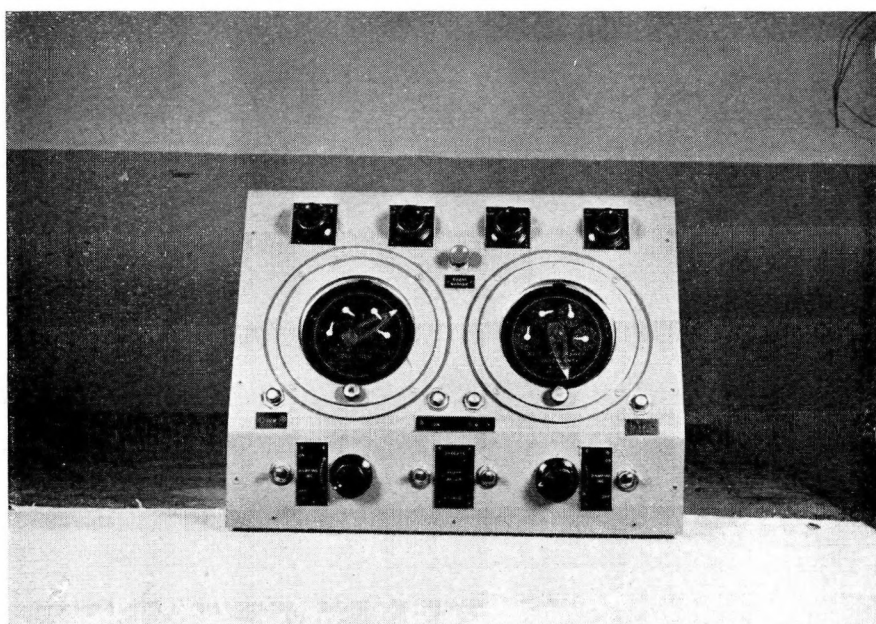

Fig. 2.

Raydist, type « ER ».

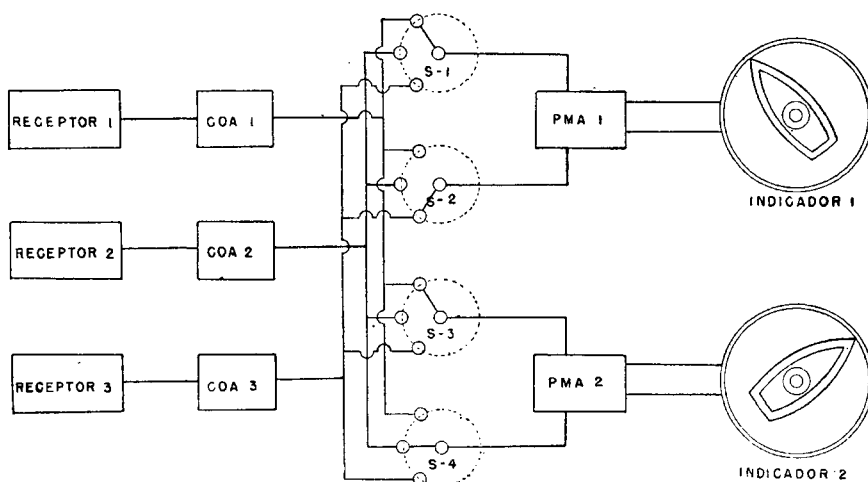

Fig. 3.

The circular station receiver receives continuous-wave signals on a frequency « f » from the Master station, and the second harmonic of the continuous-wave signal radiated by its own transmitter on a frequency « $f + \Delta f$ »; the operating frequency of this station is $1/2 (f + \Delta f)$.

The hyperbolic station double continuous-wave receiver receives signals from the Master station on a frequency « f », and from the circular station on a frequency $1/2 (f + \Delta f)$, doubling the second part and thus supplying an output beat of Δf .

The Master station amplitude-modulated receiver receives signals from the circular station on the $1/2 (f + \Delta f)$ frequency, and a signal derived from the shipborne transmitter before its final stage on a frequency $1/2 f$; the resulting $1/2 \Delta f$ beat is doubled in the receiver and supplies an output beat of $\Delta - f$.

The amplitude-modulated receivers at the three stations are so designed as to supply an output beat $\Delta - f$ at an audio-frequency of 400 c/s. This beat is transmitted from the fixer stations to the ship by modulated-frequency transmitters; the beats are received at the Master station and are compared with one another and with the Master-station beat on the phasemeters. This comparison process results in a highly accurate determination of the mobile station's position.

According to the type of comparison carried out, the ship will be located on one of a group of position lines. Thus, comparison of the signals from the circular station (C) with those from the Master station (M) locates the ship on a distance circle; comparison of the circular station (C) and hyperbolic station (H) signals locates the ship on a hyperbola whose foci are the two stations; and comparison of the Master station (M) and hyperbolic station (H) signals determines the position of the ship on an ellipse whose foci are the two fixed stations.

A block-diagram of the « ER » system is shown in Figure 4.

According to wave motion, the phase of a determined signal is $\theta = 2\pi \omega t$, which in the present case, since the angular velocity is the frequency, gives:

$$\theta = 2\pi ft$$

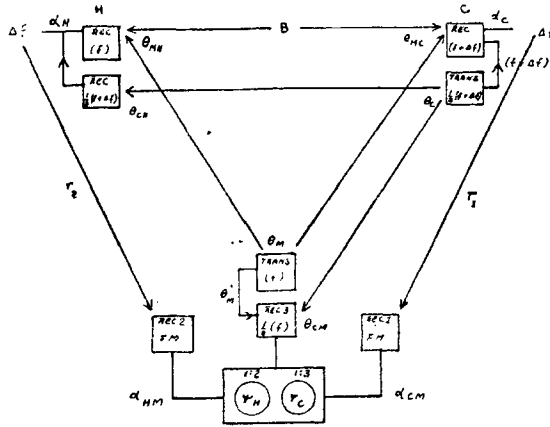

Fig. 4.

Thus the phases of the signals transmitted by the Master station are :

$$(1) \quad \theta_M = 2 \pi f t \text{ radiated towards C and H}$$

$$(2) \quad \theta'_M = 2 \pi \frac{f}{2} t \text{ radiated to station M itself.}$$

At the circular station, the phases of the transmitted signals are :

$$(3) \quad \theta_c = 2 \pi \left(\frac{f + \Delta f}{2} \right) t \text{ radiated towards M and H}$$

$$(4) \quad \theta'_c = 2 \pi (f + \Delta f) t \text{ radiated to station C itself}$$

Taking v as the velocity of radio waves, the signals upon reaching the other stations will be changed in phase according to the distance between them, i.e. :

$$(5) \quad \theta_{Mc} = \theta_M - 2 \pi f \frac{r_1}{v} \text{ from Master station upon reaching C}$$

$$(6) \quad \theta_{MH} = \theta_M - 2 \pi f \frac{r_1}{v} \text{ from Master station upon reaching H}$$

$$(7) \quad \theta_{cM} = \theta_c - 2 \pi \left(\frac{f + \Delta f}{2} \right) \frac{r_1}{v} \text{ from circular station upon reaching M}$$

$$(8) \quad \theta_{cH} = \theta_c - 2 \pi \left(\frac{f + \Delta f}{2} \right) \frac{B}{v} \text{ from circular station upon reaching H}$$

As at each of the receivers, a $\Delta - f$ beat is obtained which is the difference between the frequencies, and whose phase is the difference between the phases of

the signals received, by designating the phase of the beat as α , the phase of $\Delta - f$ at the circular station becomes:

$$(9) \quad \alpha_c = \theta_{Mc} - \theta'_c \quad \text{or, derived, from (5)}$$

$$(10) \quad \alpha_c = \theta_M - 2\pi f \frac{r_1}{v} - \theta'_c$$

The $\Delta - f$ beat is transmitted as a modulated-frequency signal to the Master station, where its phase upon arrival is:

$$(11) \quad \alpha_{CM} = \alpha_c - 2\pi \Delta f \frac{r_1}{v}$$

At the Master station, the modulated-amplitude receiver supplies the $1/2 \Delta - f$ beat, which before its output is doubled so as to produce a $\Delta - f$ signal; its initial phase is $\alpha_M = \theta'_M - \theta_{CM}$, whence from (7), we get:

$$(12) \quad \alpha_{II} = \theta'_M - \theta_c + 2\pi \left(\frac{f + \Delta f}{2} \right) \frac{r_1}{v}$$

Reducing expressions (11) and (12), we get:

$$(14) \quad \alpha_{CM} = 2\pi ft - 2\pi f \frac{r_1}{v} - 2\pi (f + \Delta f)t - 2\pi \Delta f \frac{r_1}{v}$$

$$(15) \quad \alpha_M = 2\pi ft - 2\pi \left(\frac{f + \Delta f}{2} \right) t - 2\pi \left(\frac{f + \Delta f}{2} \right) \frac{r_1}{v}$$

The circular part of the system is obtained by comparing, at the Master station, the No. 3 amplitude-modulated receiver output of the Master station with the No. 1 frequency-modulated receiver output corresponding to the circular station.

The phase difference between these signals will correspond to the comparative phase of the $\Delta - f$ beats in these receivers, and as the frequency of the No. 3 receiver beat is doubled, we shall have:

$$\psi_c = 2\alpha_M - \alpha_{CM} \quad \text{and by substituting (14) and (15):}$$

$$\begin{aligned} \psi_c &= 2\pi ft - 2\pi (f + \Delta f)t + 2\pi (+\Delta f) \frac{r_1}{v} - 2\pi ft + 2\pi f \frac{r_1}{v} + \\ &\quad 2\pi (f + \Delta f)t - 2\pi \Delta f \frac{r_1}{v} \end{aligned}$$

After factoring, $\Delta - f$ being very small, we get:

$$\psi_c = 4\pi f \frac{r_1}{v} + 4\pi \Delta f \frac{r_1}{v}$$

and neglecting $\Delta - f$:

$$(16) \quad \psi_c = 4\pi f \frac{r_1}{v}$$

As the velocity of radio waves is $v = \lambda f$, by substituting this value in expression (16), we get the distance coefficient of the circular station:

$$(17) \quad R_1 = \frac{\psi_c}{2\pi} = \frac{r}{\lambda/2}$$

This distance coefficient is the value which, when multiplied by the « lane » (one-half wavelength) will supply the value of the ship's distance from the circular station.

The Raydist « ER » system designed for the Hydrographic Office had a frequency of 4,127 kc/s, which therefore supplied a value of 36.306 m for the one-half wavelength lane.

The hyperbolic part of the system is obtained by comparing, at the Master station, the outputs of frequency-modulated receivers No. 1 (circular station) and No. 2 (hyperbolic station). The ship thus obtains its position as determined on a hyperbolic line with its foci at the two fixed stations.

Comparison of the two beats supplies:

$$(18) \quad \psi_M = \alpha_{HM} - \alpha_{CM}$$

But $\alpha_H = \theta_{MH} - 2\theta_{CM}$ since at the station (H) receiver, the part corresponding to the signal from C is doubled, whence:

$$(19) \quad \alpha_{HM} = \alpha_H - 2\pi \Delta f \frac{r_2}{v} = 2\pi f t - 2\pi f \frac{r_2}{v} - 2\pi (f + \Delta f) t + 2\pi (f + \Delta f) \frac{B}{v} - 2\pi \Delta f \frac{r_2}{v}$$

By substituting (14) and (19) in (18), we get:

$$\psi_H = 2\pi f t - 2\pi f \frac{r_2}{v} - 2\pi (f + \Delta f) t - 2\pi (f + \Delta f) \frac{B}{v} - 2\pi \Delta f \frac{r_2}{v} - 2\pi f t + 2\pi f \frac{r_1}{v} + 2\pi (f + \Delta f) t + 2\pi \Delta f \frac{r_1}{v}$$

which supplies, neglecting the small $\Delta - f$ terms:

$$(20) \quad H = \frac{\psi_H}{2\pi} = \frac{r_1}{\lambda} - \frac{r_2}{\lambda} + \frac{B}{\lambda} = \frac{1}{\lambda} (r_1 - r_2 + B)$$

which will be the value appearing on the corresponding phasemeter.

Since it is desired to determine the distance coefficient with respect to the hyperbolic station, and the distance coefficient with respect to the circular station is taken directly from the instrument, it suffices to combine expressions (17) and (20) into:

$$(21) \quad 2H = \frac{1}{\lambda/2} (r_1 - r_2 + B) = R_1 - R_2 + B \quad \text{whence, extracting}$$

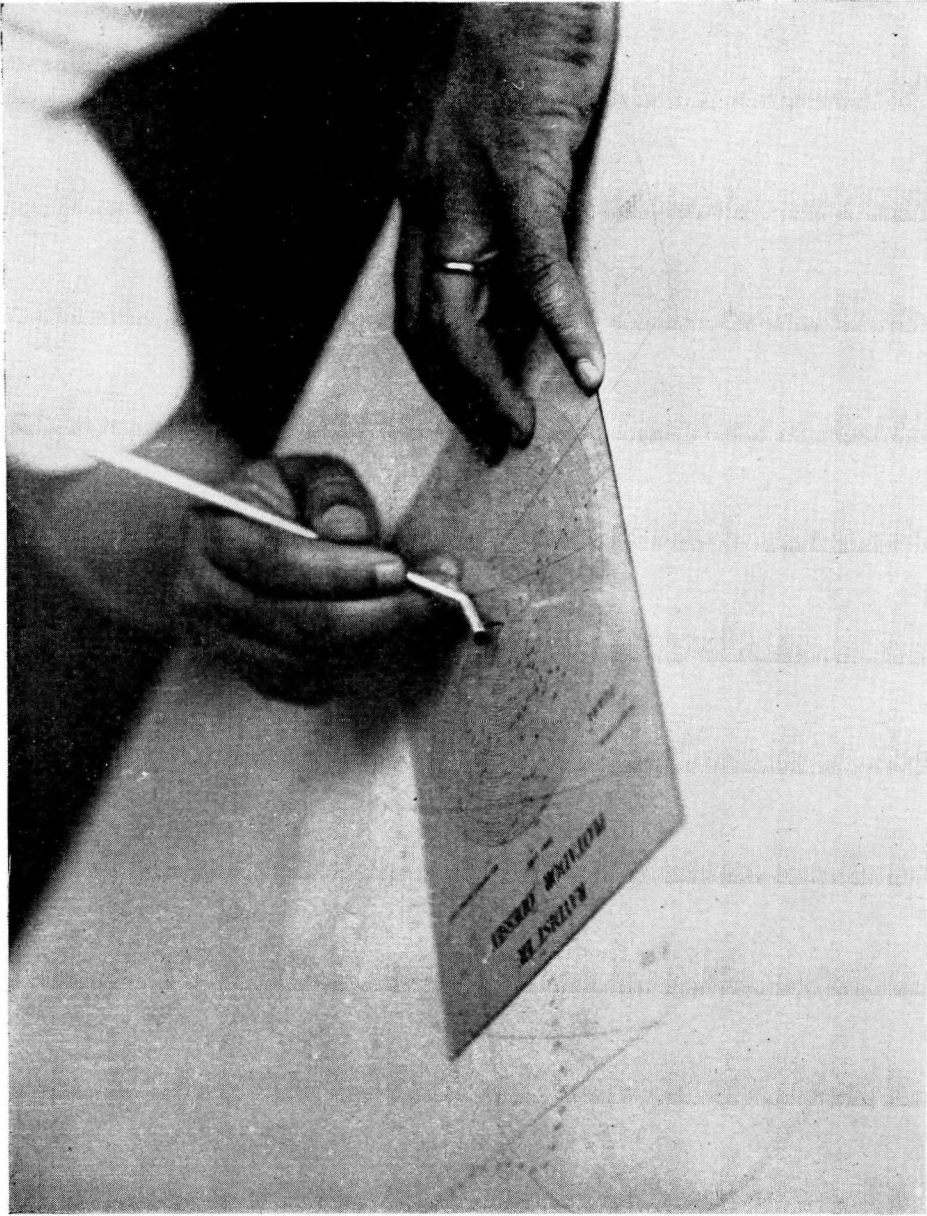

Fig. 5.

$R_2 = R_1 + B - 2H$, we get the distance coefficient of the hyperbolic station.

The values to be introduced in the manual computer are the distance coefficient R_1 of the circular station, and the value of H , resulting in the distance coefficient R_2 of the hyperbolic station: in plotting the position, only these two values are used.

The equipment also enables an elliptical solution to be obtained by comparing the phases of receivers No. 3 of the Master station and No. 2 of the hyperbolic station.

$$\psi_E = 2\alpha_M - \alpha_{HM}$$

while from (15) and (19), we get:

$$2\alpha_M = 2\pi f t - 2\pi(f + \Delta f)t + 2\pi(f + \Delta f) \frac{r_1}{v}$$

$$\alpha_{HM} = 2\pi f t - 2\pi f \frac{r_2}{v} - 2\pi(f + \Delta f)t + 2\pi(f + \Delta f) \frac{B}{v} - 2\pi \Delta f \frac{r_2}{v}$$

Substituting these values, factoring, and rejecting the $\Delta - f$ terms as being negligible, we get:

$$\psi_E = 2\pi \frac{r_1}{\lambda} + 2\pi \frac{r_2}{\lambda} - 2\pi \frac{B}{\lambda} \quad \text{or,}$$

$$2E = 2 \left(\frac{\psi_E}{2\pi} \right) = \frac{r_1}{\lambda/2} + \frac{r_2}{\lambda/2} - \frac{B}{\lambda/2} = R_1 + R_2 - B$$

Determination of position. Positions are determined by reading the two phasemeters simultaneously and obtaining the values of R_1 and H . To obtain the value of R_2 , which is the distance coefficient with respect to the hyperbolic station, the following expression may be computed:

$$R_2 = R_1 + B - 2H$$

This computation may reliably be made by means of a special computer when values to within only one-tenth of a lane are desired.

With the computer regulated before the operation to supply a value of R_2 equivalent to B when R_1 and H equal zero, the operator introduces by means of the cranks therein the values of R_1 and H obtained from a simultaneous reading of the phasemeters, and the desired value appears in the slot corresponding to R_2 .

Plotting of position (Figure 5). The Raydist sounding-sheet must be prepared with distance circles 100 lanes apart, centred on the two stations, the circles being drawn in a different colour for each station.

The Odessey Plotter, which is constructed on the same scale as the sounding-sheet, consists of circles graduated from 0 to 100 from the centre.

On the assumption that the values obtained in computing the position are $R = 1352$ and $R = 830$, the procedure is as follows:

(a) Circle No. 52 on the plotter is so placed that it is externally tangent to Circle No. 1300 of the circular station, and

(b) The former tangency being maintained, the 30th division of the plotter is made externally tangent to Circle No. 800 of the hyperbolic station.

(c) The point determining the position is pricked through with the appropriate stylus, and a small circle drawn around it. The number of the position is then written beside it.

An appropriate sounding-book is used to record the readings and soundings.

Calibration. As in all radio position-fixing systems using the phase-comparison method, Raydist requires calibration with respect to a known position determined by other means before sounding operations can be undertaken.

As the shore on the North Bar of the Amazon is uniform and points are sufficiently defined for positions to be fixed by visual methods, calibration was effected by determining the ship's position in relation to Rio Branco lighthouse, which is located on a shoal in open water, and at the apex of local triangulation.

Owing to the topographic and hydrographic character of the area, the ship could proceed to within about 200 metres of the lighthouse and anchor there, its position being determined by distance and bearing. Distances were determined by stadimeter.

A Raydist sheet was constructed to twice the scale of the sounding sheet, the position plotted upon it, and the readings of R_1 and R_2 were taken to compute the value of H by the formula :

$$H = \frac{R_1 + B - R_2}{2}$$

The values of R_1 and H were introduced into the phasemeters, and sounding operations then commenced.

This was the most advisable procedure in this area, and resulted in a satisfactory solution to the problem involved.

Recorder. To ensure reliability of operation, Raydist is equipped with a recording instrument which is connected to the phasemeters and records the movements of the larger needle in a tooth-shaped diagram, as illustrated in Figure 6. The upper section shows the circular part and the lower section the hyperbolic part.

Near the bottom of the paper, moreover, is a mark showing the position at the time of actuating the recording knob of the indicator.

The teeth require to be graduated, and for this reason, whenever the needle passes through zero, completing ten graduations, one of the operators notes the reading next to the corresponding tooth, which coincides with the sounding number.

This method enables a check later to be made of the observers' work and thus to check errors found; the graph likewise enables verification of signal-quality according to the evenness of the plot: if Signal No. 1 reception is poor, both

graph-sections will be poorly reproduced, since this signal is involved in the comparison of the circular and hyperbolic parts if Signal No. 2 reception is poor, then reproduction of the hyperbolic part only will be affected.

Examination of the graph will also reveal loss of a lane, which means a momentary interruption in the operation of one of the phasemeters; in this case, the previously even record will show an alteration, adding an error to all subsequent readings, if not corrected in time. The phasemeters are therefore equipped with control-knobs enabling immediate correction.

Figure 6 shows loss of lane in the hyperbolic part, following reading 618. If the correction had not been made, all subsequent readings would have involved an error of 2 lanes.

Normally there is no lane loss, although such may occur in the case of interference, defective transmission at one of the stations, or owing to the appearance of « night effect ».

Night effect. Night effect appears to result from the simultaneous reception of the direct and reflected waves of the transmitted signals, which produce a continuous phase variation independently of the motion of the ship. In the phasemeters this may be detected by the oscillation of the larger needle, a recording of which is shown in Figure 7, where the effect is relatively slight and still enables the ship to operate. The officer in charge must nevertheless be on the look-out for any lane losses requiring correction. In certain cases, such as on the occasion of the North Bar expedition, the phasemeter readings may be disregarded, and the officer can obtain the position from the recorder at the time of sounding.

This method is not advisable when night effect is strong, as the oscillations of the needles are such as to prevent the position from being obtained from the graph. The best procedure in this case is to anchor in order not to lose calibration, and to wait until the following day before resuming operations.

Equipment of Mobile Station. The shipborne Raydist ER station consists of the following parts:

- (1) TA-70B 4127 kc/s CW transmitter, with 10-w output.
- (2) FB-20 CW amplifier, same frequency, with 100-w output.
- (3) QB-28 CW Antenna load-unit.
- (4) ZA-36 Master station containing the three receivers, three constant output amplifiers and two PMA's.
- (5) GA-23 Indicator with phasemeters.
- (6) TE-25 Test equipment.
- (7) SA-117 Power source for ZA-36.
- (8) SA-121 Power source for GA-23.
- (9) Recorder.
- (10) Two modulated-frequency receiving antennae.
- (11) 36-foot telescoping transmission antenna.
- (12) 36-foot telescoping receiving antenna.

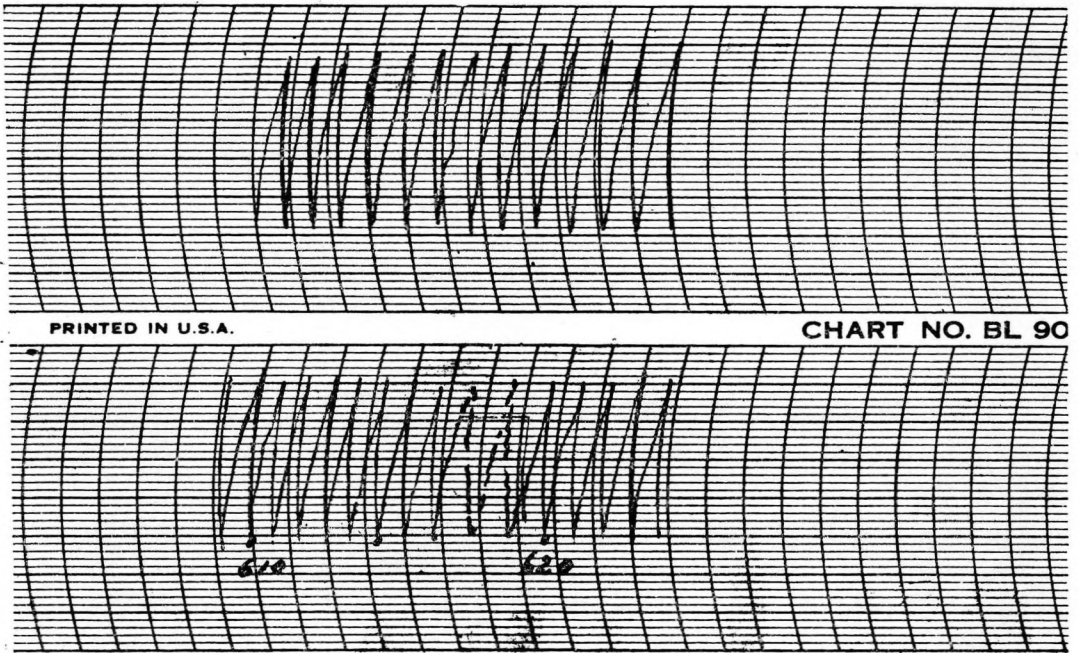

Fig. 6.

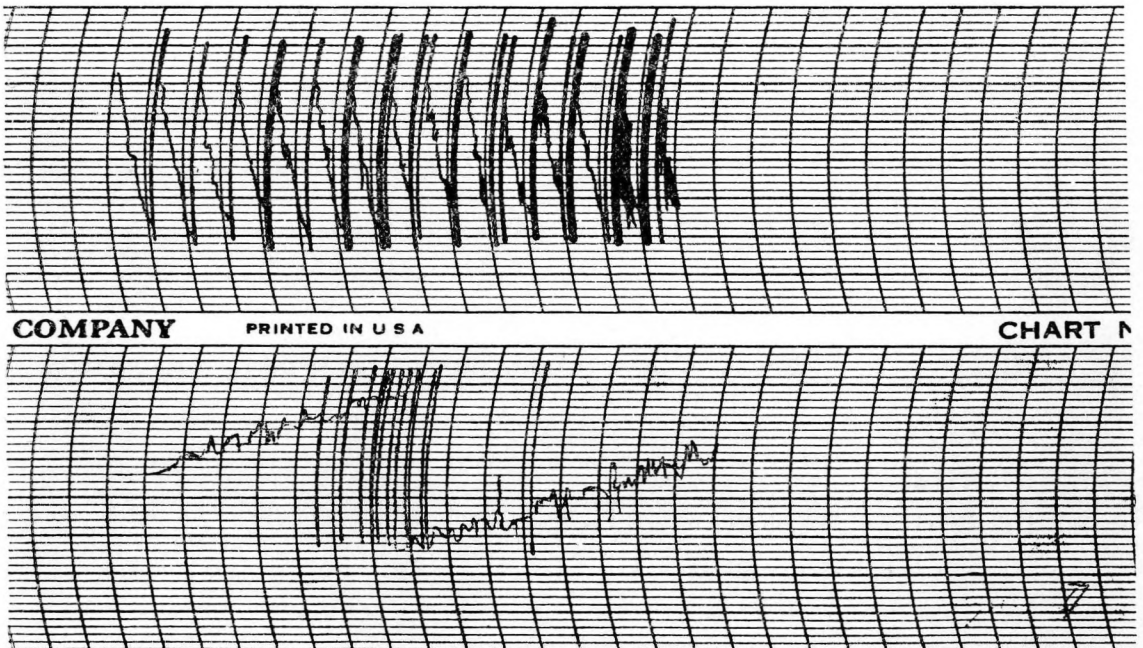

Fig. 7.

Equipment of Circular Station. The circular fixed station consists of the following equipment :

- (1) TA-71B 2063.7 kc/s CW transmitter, with 10-w output.
- (2) FB-20 CW amplifier, same frequency, with 100-w output.
- (3) QB-28 CW antenna load-unit.
- (4) AA-25 Circular relay station containing AM receiver and FM transmitter with 10-w output, frequency 32.7 Mc/s.
- (5) FB-14 FM amplifier, with 100-w output.
- (6) 60-foot mast for CW transmission.
- (7) 60-foot mast for AM reception.
- (8) FM antenna for transmitter.
- (9) 115-V, AC gasoline motor-generator.

Equipment of Hyperbolic Station. The other fixed (hyperbolic) station consists of the following equipment :

- (1) AA-46 Hyperbolic relay station containing the AM receiver and 10-w FM transmitter, frequency 34.74 Mc/s.
- (2) FB-14 100-w FM amplifier.
- (3) 60-foot mast for AM reception.
- (4) FM antenna for transmitter.
- (5) 115-V, AC gasoline motor-generator.

Evaluation of results. In carrying out the Raydist soundings for Chart 201, the stations were first used at Bailique and Santarem, and at Para and Guara during the second phase. The charting was thus done in a south-north direction until determination of the approach channel to the North Bar of the Amazon.

The Raydist operations may be divided into two phases. The first phase, with the stations set up at Bailique and Santarem, began on 2nd May and ended on 24th September, consisted in acquainting ourselves with the equipment and of a period of training under the direction of a technician from the Hastings Company. A series of breakdowns and defective operation occurred during this stage, which speedily improved our knowledge of the equipment.

The second phase, or the actual operational phase, began on 6th October and ended on 11th November, in the combined location of soundings by Raydist and astronomical fixes when we were within range of the equipment.

The results of the second phase, as they should have been, were much more satisfactory owing to better ground installations, better handling, and to increased acquaintance with the instrument, as may be ascertained from the following :

Phase 1	Bailique-Santarem	4 mos. 5 days	137 sq. m.
Phase 2	Para-Guara	1 mo. 3 days	110 sq. m.

The arrangement of the antennae during the second phase was devised following a study of the radiation patterns, the antennae of the hyperbolic station being kept in alignment with the centre of the sounding area, while the two masts of the circular station, located 30 m apart, were aligned in a direction perpendicular to the centre of the sounding area.

The ground plane installation for the Raydist masts considerably improved transmission, and consequently operational performance, despite the fact that during Phase 2 the Para Island station was on sandy soil, which is a poor conductor.

In addition to the placing of the antennae in relation to the area of sounding, their remoteness from metallic structures and high trees appears to have contributed to improved performance during the latter stage.

With respect to accuracy, notwithstanding the impossibility of obtaining constant checks by other means in the area, we were able to carry out soundings on various days, and upon returning to the calibrated position, discover that our position was correct.

As regards range, the latter was normally limited to 36 nautical miles, although a 54-mile range was reached upon one occasion during a six-week period. The frequency-modulation characteristic is responsible for range limitation; for this type of transmission, range is slightly in excess of that of the horizon. The frequency-modulation antennae were installed on 60-foot masts at the fixed stations, and on 40-foot masts on board ship, with a low-lying coast. By taking advantage of a sheer coastline, however, much longer ranges can be obtained, as normally an output power of 100 w is used.

On board the *Rio Branco*, which is more than forty years old and whose electric installations are defective, it was necessary to disconnect the radio transmitters, ventilators and various other electrical equipment owing to their interference with Raydist operation.

A great advantage of Raydist is that the personnel operates according to a relatively easy routine, under cover, with adequate comfort, and thus with increased efficiency owing to the fact that the equipment can be used in hydrographic operations over a longer period. Near the stations the equipment can be run 24 hours a day.

In obtaining the soundings for Chart 201, we used an American NJ8 echo sounder with a bottom oscillator, and a Brazilian EB-4 machine. Calibration was effected by means of a hand lead, since we could not make bar checks.

Raydist « ER », Model II equipment. This equipment was likewise recently acquired in the United States, but has not yet been used in hydrographic operations. It is a modified version of Model I and uses amplitude modulation instead of frequency modulation for the return signals from the fixed stations. During tests carried out in Chesapeake Bay, in spite of the poor shipborne installation and ordinary installation at the fixed stations, a maximum range of 68 nautical miles was obtained. However, with an installation in a steel ship a normal range of 100 nautical miles may be expected.
