

HYDROGRAPHIC SOUNDINGS IN SURF AREAS

by Captain Henri DUFFO (Ret.), French Navy

In the course of a recent survey on the West Coast of Africa which the Laboratoire Central d'Hydraulique de France asked me to undertake on behalf of the Ivory Coast Refining Company I was asked to extend our sounding lines *through the surf areas*, if possible as far as the chart datum.

Studies of this kind are of very little interest for standard navigation; however during the war the Allies were led to make such studies with a view to facilitating landing operations. It was essential to know how to predict the presence of trenches and their size, since the stranding of barges on the first ridge formed by swell could have serious consequences.

However such investigations made directly in the field (where there no longer exists any enemy defence), and without the aid of any mathematical approach which does not always yield unanimously accepted results, might equally well have an interest for peace-time activities. Beaching is sometimes necessary when large undertakings have to be carried out at points on the coast where no facilities are available — neither the means of coming alongside, nor access roads, nor railways. Thus, for instance, in Cambodia the wharf at Sihanoukville was practically completed before the road which was to serve it was finished.

Finally these researches on the effect of swell on shores have considerable scientific interest. Repeated, such researches allow us to compute accurately the annual rate of material deposit, and even its seasonal variations: they ought to proceed on an equal footing with laboratory work whose interpretations they help to correct, whilst specifying the shape of the model in areas where marine charts give only very few indications.

I therefore think it useful to outline a method whose principle is very simple, and which, with relatively modest means, can supply a good solution to the problem being considered.

*
**

This problem, it will be said, does not arise in favoured regions which, at certain seasons, enjoy good climatic conditions when there is hardly any swell. Launches can then carry out soundings by one means or another up to the point where they ground themselves. In this case, however, a hydrographic survey, except perhaps when it is carried out immediately after a period of swell, runs the risk of not giving the required information. The soundings will take into account the roughness in the profile of a beach

created by a continuous swell and its subsequent development only if they are executed during the period when swell is dominant. Furthermore unfortunately there exist coasts where there is always a swell — a swell arising from distant meteorological depressions which follow one another without interruption, as in the case of the southern depressions. When the swell is smooth the accuracy of soundings by ultra-sonic means registered at sea is only slightly affected. However near the land the surf increases, and the sounding launch pitches and rolls more and more heavily as she approaches the surf area; the accuracy and correctness of the soundings then becomes uncertain.

In fact, if by smoothing the curve on the record, errors due to the vertical movements of the transducers are eliminated, other errors will still be present because the axis of the ultra-sonic beam deviates noticeably from the vertical. The corresponding corrections cannot be determined: it is known only that in cases where the bottom is flat the mean soundings supplied by a launch which was being heavily rocked are always too deep.

At great expense the American Navy has resolved the difficulties of sounding in rollers by the use of self-propelling sea-sleds and "dukws" (amphibious craft), but I have never read a detailed description of the methods used, and I do not know if they properly eliminated the soundings affected by the increase in height due to the swell both before and while encountering the surf area — that is in relatively significant depths up to 6, 8 and even 10 m.

*
**

The principle of the method used was very simple.

A native canoe, leaving the beach, broke through the rollers. It ran out towards the open sea a coil of rope one end of which is retained on land, a heavy fish-lead being fixed at the other end. To this fish-lead a self-ascending balloon is attached at the usual point of suspension by a very fine wire whose length is approximately twice that of the maximum expected sounding, but of course a good deal lighter in weight than the fish-lead in the water (figs. 1 and 2).

When the launch reaches the starting point of the proposed sounding line the fish-lead is cast down and the balloon goes down the several metres which approximately represent the depth (*).

The role of the native canoe is then finished. The first set of angle measurements can be carried out, and the first sounding made.

The position of the fish-lead on the bottom can be varied, for instance every 5 m, by hauling in onto the beach the required length of rope run out by the canoe. In this way regularly spaced soundings which will be approximately in a straight line will be obtained.

In using a canoe we were of course employing local means; the coil could, however, be put ashore from any previously anchored launch outside

(*) In practice our fish-lead was cast when the coil of a suitably chosen length was completely unwound.

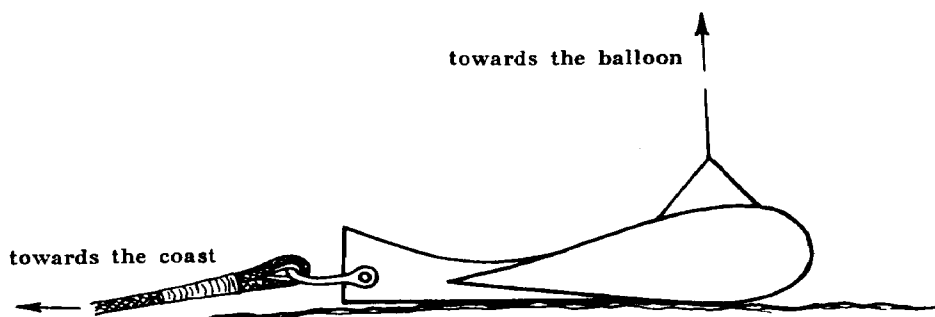

FIG. 1

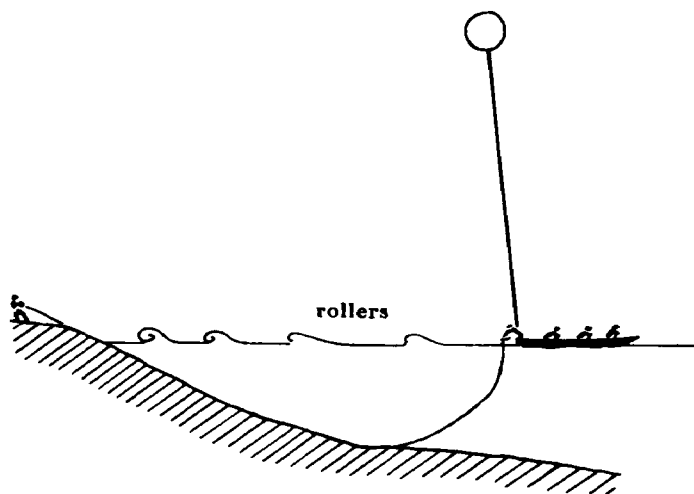

FIG. 2

the area of the rollers if a sufficiently powerful rope-launching gun were available.

**

Let us consider the case of fig. 3 where the wire is exactly vertical: this assumes that the air is perfectly still and that the balloon has sufficient lifting power for the wire to remain practically taut and unaffected by the movement of the water.

P is the point of contact of the fish-lead with the bottom, P' the point where the wire is attached, P'B the wire, B being the lower part of the balloon at a height $L = PB$ from the bottom, M a previously selected point on the wire at a distance $l = PM$ from P; P, P', M and B being on the same vertical.

The observer, whose eye is at point O in the plane of the figure, then measures the angle of elevation $\sigma = \widehat{mOM}$, (mO being horizontal).

Let H be the intersection of the vertical of point O and the horizontal of point P, N the point where this vertical intersects the plane of sounding datum, which is itself intersected at n by the vertical of P. We then have :

$NH = nP = s$, sounding at point P.

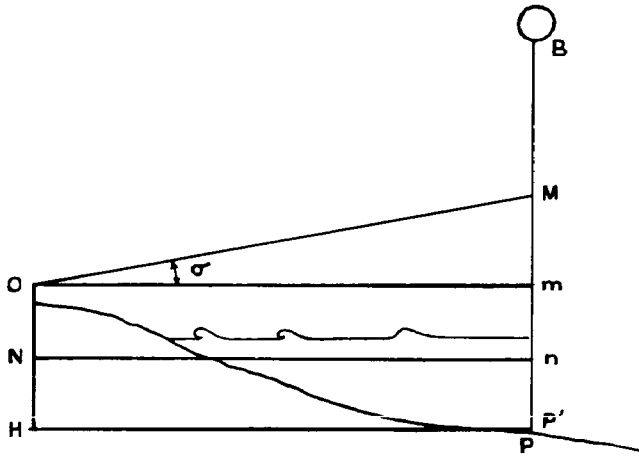

FIG. 3

$ON = mn = h$, height of the observer's eye above the sounding datum plane; the value of h can be accurately determined by precision levelling.

$Om = Nn = HP = D$. D is the horizontal distance from O to P .

Let us call :

$$Z = h + s \quad \text{the length } OH = mP \quad (1)$$

We then have :

$$Z = l - D \tan \sigma \quad (2)$$

(counting σ as positive if M is above m , as negative if the contrary is the case) whence :

$$s = l - D \tan \sigma - h \quad (3)$$

l and h are known; σ is measured; D will be computed by three resections taken from O and two other observational stations O' and O'' , these last two being selected so that the diamond of error is good.

The study of the error Δs on the sounding thus computed, under those theoretical conditions, will allow us to obtain an idea of this method's limits of accuracy.

Let us neglect the error on both h and l . Differentiating, we obtain:

$$\Delta s = -\Delta D \tan \sigma - D \Delta \sigma (1 + \tan^2 \sigma) \quad (4)$$

If O , O' and O'' have relative positions known to within 3 or 4 cm, it is easy to select P within a maximum uncertainty of a millimetre when the three resections are plotted at a scale of $1/500$: we shall then obtain D with an error of the order of 0.25 m.

By noting that $\tan \sigma = (l - s - h) : D$, $\Delta D \tan \sigma$ then becomes $0.25 (l - s - h) : D$.

Three observation stations were used and we shall see that we can equally well take *two* points M , one being point B and the other being the midpoint of BP ; the two values of l will then be L and $L : 2$.

If s varies from zero to 8 m it will be necessary to choose L in the vicinity of 20 m. As for h , this will depend on the configuration of the

back-beach area, but we may assume as true that it falls between 5 and 10 m. The maximum value of $l-h$ will therefore be 15 m.

When the distance is large then $D \Delta \sigma (1 + \tan^2 \sigma)$, whose principal value is $D \Delta \sigma$, will be relatively large when D is large. If a sufficiently accurate instrument is used — for example a sextant reading to $10''$, we can be sure of obtaining the angle of elevation to better than within one minute.

The maximum value of this second term would therefore be $D : 3000$.

The total *maximum* error will be very nearly

$$0.25 \frac{15-s}{D} + \frac{D}{3000}$$

Let us examine its value when s varies from 0 to 8, D varying from 300 down to a minimum representing the distance between the spot where the fish-lead crossed the zero depth line and the nearest observation station O, O' or O'' — a minimum which can scarcely be less than 30 m.

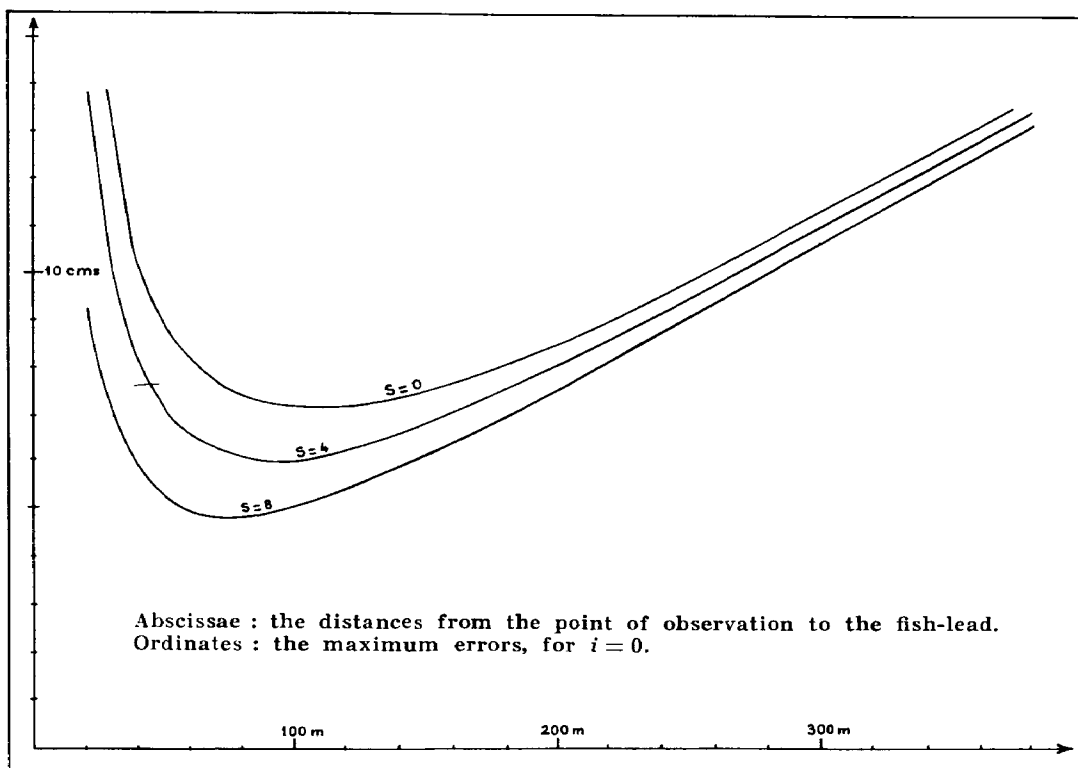

FIG. 4. — Representation of the function $f(D) = 0.25 \frac{15-s}{D} + \frac{D}{3000}$ (maximum error on sounding s) for $s = 0, s = 4, s = 8$, with $i = 0$.

The graph in fig. 4 shows that within the envisaged limits the total maximum error is very small. Through the use of weighted means of six soundings computed from three observation stations (certain of these can be omitted when they have been obtained under poor conditions) we can in practice hope to obtain depths to within better than 20 cm — even

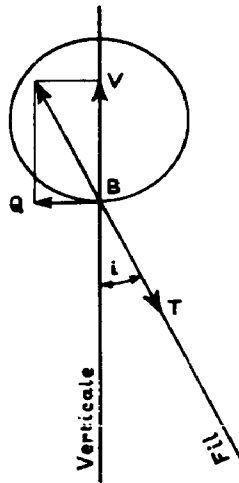

FIG. 5

when errors such as that due to slanting wire, whose significance I shall be later assessing, are included in the total.

*
**

As I have said the example is a theoretical one; in reality further difficulties complicate the problem.

For our own trials we used :

- a fish-lead of about 20 kg,
- a 1-mm diameter steel wire 20 m in length (*). In any case we shall consider the weight of the wire as negligible in relation to the lifting power of the balloon (about 3.5 kg for a balloon diameter up to 2 m).

Our first difficulty arose from the fact that the wind was not zero, although luckily it was very slight — at most 2 m per second. With the equipment used, however, it would appear that this speed of 2 m per second is a maximum which must not be exceeded or else the method will quite rapidly lose its anticipated accuracy. In a more general way, the practical rule should certainly be that the angle i which the wire makes with the vertical should not exceed 10° .

If we assume the wind speed to be constant and equal to W we shall see that at the balloon's point of attachment B (fig. 5) three forces must balance out :

- \overline{BV} , the lifting power; its value being the volume of the balloon multiplied by the difference in density between air and hydrogen;
- \overline{BQ} , the pressure of the wind (assumed horizontal) on the balloon;

(*) More exactly that which we call L — i.e. PB — was equal to 20 m : an error was thus introduced when the wire is not vertical; but this error PP' $\left(1 - \frac{1}{\cos i}\right)$ is negligible, PP' being very small; in fact in fig. 6 we have cut out P' , assuming instead that the wire starts from P , PP' being considered zero, and the weight of the lead concentrated at point P .

we can assume that this is proportional to the surface of a great circle and to the square of the wind speed;

— the strength BT , tangent to the wire, therefore making an angle i with the vertical so that:

$$\tan i = BQ : BV \quad \text{i.e.} \quad (5)$$

$$\tan i = k W^2 : R \quad (6)$$

where

W is the wind speed

R the balloon's radius

k a constant.

Obviously i can be made smaller by increasing R ; but a 2-m diameter balloon is already difficult to handle. I believe therefore that the method must only be used in sufficiently calm weather.

In the Bight of Bénin, where we were operating, the wind was usually remarkably slight during the first three or four hours of the morning.

In any event we shall assume that i reaches a maximum of 10° , a figure which I shall use later in an account of the computation of errors; we shall also assume, under the condition that this assumption will later be justified, that PB is an almost straight line.

Let us consider fig. 6 where the letters $O, N, H, B, M, m, \sigma,$ and P have the same meaning as in fig. 3.

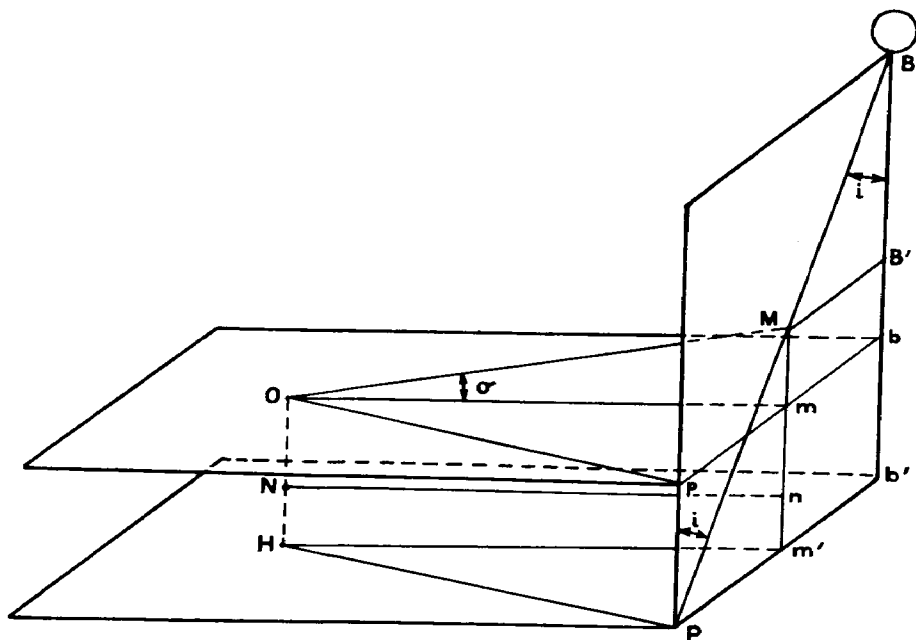

FIG. 6

b and b' are vertical projections of B on the horizontal planes passing through O and P : in fig. 3 they were the same as the projection of M .

m' is the projection of M on the horizontal plane of P (when PB is vertical this is the same as P).

p is the projection of P on the horizontal plane of O. In fig. 3 this is the same as m .

B' is the projection of B on the horizontal plane of M. As already said i is the angle of PB with the vertical.

If we always designate by D the horizontal distance from the observer's eye to point P, then the horizontal distance from the observer's eye to point M (a distance which is only equal to D when $i = 0$) will be designated by D' , ($D' = Om$).

Formula (1) above is not changed and formula (2) becomes :

$$z = l \cos i - D' \tan \sigma \quad (7)$$

and formula (3) :

$$s = l \cos i - D' \tan \sigma - h \quad (8)$$

The position of the projection of M is determined as before by *three* resections and D' is obtained with the same accuracy as D for $i = 0$.

However when computing the errors it will be necessary to add a third term arising from i (which cancels out with i),

$$l \sin i \Delta i$$

In fact :

$$\Delta s = -l \sin i \Delta i - \Delta D' \tan \sigma - D' \Delta \sigma (1 + \tan^2 \sigma) \quad (9)$$

The inclination i is an essential data and its determination, although very simple in theory, can only be made indirectly and requires the greatest care.

Earlier on I said that all the measurements would be carried out for two points M; — however this is done not only to obtain a double number of soundings at each station, and consequently to be able to adopt more accurate values — these double measurements allow us to determine i .

Since the second M point is obviously the point B already fully defined, we shall have :

$$\sin i = MB' : (L - l) \quad (10)$$

which allows us to compute i , and by differentiating to deduce Δi from the formula :

$$\cos i \Delta i = \Delta(MB') : (L - l) \quad (11)$$

The term $l \sin i \Delta i$ therefore becomes :

$$l \sin i \Delta i = l \tan i \Delta (MB') : (L - l) = \tan i \Delta (MB') \quad (12)$$

since M is in general selected at the middle of PB.

Moreover, $MB' = mb$; if the errors in the positions of m and b , evaluated at 0.25, are added, $\Delta (MB')$ will be at the most 0.50, and the third corrective term will be less than 9 cm when i is less than 10° .

*
**

The method would therefore be excellent if everything took place as planned, that is if all our assumptions proved themselves true.

However, as soon as there is even the slightest wind, this wind does not remain constant, and furthermore vertical components of the balloon's speed probably intervene. Briefly — a turbulence almost always exists

causing the balloon and its wire, i.e. B and M, to swing around a mean position.

However only formulae (4) and (5), which we used simply to examine how i could be decreased, imply that an equilibrium could be worked out; all the other formulae used to compute the sounding remain accurate, contingent upon all the observations having been made simultaneously and at a moment when the wire PMB was taut. It seems that the forces acting on the wire, which proffers a very small surface to wind and wave action, are negligible in relation to the traction exercised by the balloon. However there may perhaps be an anomaly when the wire happens to be caught in a surf area.

In any event this is an occurrence which should be avoided, and as we shall see this may easily be done.

In fact, since the balloon swings it is necessary, as we have already seen, that the sights to B and to M should be taken at the same instant — obviously a moment when the surf is breaking on the wire should not be chosen. The person giving the count-down has, therefore, an important task. He should make a point of giving the 'go' signal when the balloon reaches its extreme limit. Its apparent speed being then zero, the sights will then be easier to take and therefore more accurate.

As always, the value of the method will depend on its execution.

We have seen that besides a towing team on land to change the fish-lead location *three* observational teams will be necessary, and these must obviously be linked together by radio.

Each of these three teams includes *one*, or if possible *two*, recorders and *four* observers who give at each 'go' signal :

- the B angle of elevation
- the M angle of elevation
- the B direction
- the M direction

It will be possible to verify in the following way both whether the angles have been carefully taken and whether the basic hypothesis (that of the taut wire) proves itself correct.

If, owing to the turbulence, the position of b and of m varies at each 'go' signal the position of p should on the contrary remain fixed, this position — i.e. that of the sounding — must in any event be fixed.

Obviously b , and then m , can be plotted and bm can be extended by mp equal to $bm [l : (L - l)]$.

When the trials were made on the Ivory Coast, M being the centre of BP, it sufficed to adopt for p the symmetrical of b with relation to m .

Nevertheless we advise a procedure which is not theoretically true, but which is practically so when mb is small in relation to Ob (or Om), which will thus lighten the already wearisome task of computation.

At each station the bearing of p is directly computed for each 'go' signal by adding an angle equal to $\widehat{bOm} \times [l : (L - l)]$ to the angle giving the direction of m .

For one and the same station the angles thus found must be practically equal — eventually, data which have to be eliminated at once can be marked. Trained recorders can even carry out this operation in the field, and then observations at a new fish-lead position would not be undertaken until *three* corresponding measurements at the *three* observation stations were correct. Finally only *b* and *p* remain to be plotted, *i* being given by the formula :

$$\sin i = bp : L$$

Each observation station will supply at each position *two* soundings for each of the *three* valid measurements, that is eighteen in all : after the elimination of incidentally faulty figures it can be assumed that the mean soundings, weighted if necessary, must be quite adequately accurate.

*
**

The mediocre means which we had at our disposal in the Bight of Bénin did not allow us to put the procedure I have just described into practice. We had only two observational stations, one of which functioned very imperfectly. Moreover for reasons which I shall later recount the accuracy of the observations was a little sacrificed to rapidity.

Nevertheless, the agreement between the different soundings was shown to be very satisfactory. The three profiles carried out, when plotted on a plotting sheet, enabled accurate bathymetric lines to be drawn.

The major difficulty arose from the fragility of the balloons used. These were lent by the Ivory Coast Meteorological Office, whose spirit of cooperation cannot be too highly praised. These balloons were the best available on the spot but, used for work for which they were not intended, they burst after less than an hour and thus obliged us to operate in trying haste.

However it seems to me that the manufacture of balloons able to be towed in slight wind and at a slow speed for as much as two or three hours without bursting should not raise insoluble technical problems.

This procedure, which is seemingly likely to be shown as the most economic and above all the most accurate, merits an attempt to carry it out under the best conditions. It calls for painstaking office-work, which we have not emphasized : in particular at each station the four operators assumed to be at O actually occupied four closely placed but separate stations. There will therefore be additional but known corrections to both horizontal distances and heights.

At all events the quality of the results justifies the acceptance of long and tricky office-work; with a little ingeniousness this could furthermore be considerably simplified.

*
**

The carrying out of such a plan on the other hand would appear a heavy task in cases where only limited information is needed, and particularly if this is required quickly.

In this case, as soon as suitable balloons have been obtained, it would be interesting to drag along the bottom a cable provided with four or five fish-leads, each one supplied with balloons suspended by wires of equal length.

Sufficiently close for the wind action on each of them to be almost the same at the same instant, these balloons, when seen from a lateral observation station, could give an immediate idea of the bottom profile and of the depth of any coastal trench.

I would add that this process, thought out with a view to giving approximate information rapidly, could be used in such a way as to supply very accurate results if the processing of data were simplified. The balloons, if photographed simultaneously with a remote-controlled camera, suitably levelled and trained, would allow accurate soundings to be taken. It would also be economical on specialized personnel whose number is far from increasing proportionately to world needs.