

HYDROGRAPHIC SURVEYING AND DATA PROCESSING

by A. THUNBERG

Head of Survey Techniques
Hydrographic Department
Swedish Board of Shipping and Navigation

Lecture given at the 9th International Hydrographic Conference

Summary

Description of a system of automatic data processing for use in hydrographic surveying produced for the Hydrographic Department of the Swedish Board of Shipping and Navigation.

* *

In recent years we have encountered major problems in many fields when asked to try out new techniques and methods with a view to maintaining or increasing production despite lack of qualified personnel and to fewer working hours. This problem has been particularly acute in government enterprises. Thus the Swedish hydrographic surveying authorities have been faced with the necessity of finding alternative means for making measurements, and assembling them for processing and recording the results. The principles of our work and the results achieved have already been described in a series of articles in *The International Hydrographic Review*. On the other hand the data processing system worked out by the Hydrographic Department in collaboration with a firm of consultants has been touched on only briefly — at the 1962 International Hydrographic Conference and in a short announcement in the *Bulletin*. The ADP system has been demonstrated to hydrographers from several countries. However it is only now that we feel we have had sufficient practical experience of the system to be able to present it more thoroughly. The requisite sub-routines have been worked out and the programme system can now be regarded as complete.

When this report was written the data processing system had been operating for somewhat more than two years, and the experience derived from it is manifestly positive. This does not, however, mean that the system has not been revised during this time, and further modifications will be made in order to deal with the numerical data more rapidly, thus improving the economy of the processing work.

The background

About ten years ago an analysis was made of the needs of hydrographic surveying in Swedish waters. It was found that with the system then in use it would take about seventy years to survey the sea areas and archipelagoes satisfactorily. From various quarters we received requests for a less time-consuming survey programme. There was a particularly well justified need, for purposes of national economy, for a better knowledge of hydrographic conditions for use in transport economy studies in connection with harbour projects.

During the last few years the Hydrographic Department has been engaged in experimental work with a view to increasing its capacity within the framework of the personnel and economic resources at its disposal. There is no need to go into details; we shall here only indicate the measures which first led to the adoption of automatic data processing methods.

Formerly the echo-sounder equipped surveying craft for sea surveys were large, relatively heavy, and slow (i.e. approximately seven knots). They were also expensive, both to purchase and to maintain. Usually these boats needed a crew of six men, including two qualified surveyors. In this system a depth record was kept during the measuring routine by the boat's crew. These figures were later entered on charts by specially trained personnel. In relation to the amount of measurement data assembled this method called for personnel and materials in considerable quantity, particularly during surveys at sea using vessels with large crews. Nor did this method offer much scope for increasing capacity within the framework of available resources.

The amount of data gathered, in relation to the manpower and materials available, has increased significantly, even for coastal and archipelagic waters, with the introduction of parallel sounding and electronic positioning.

In a parallel-sounding formation of nine sounding boats for example, the personnel can consist of two qualified surveyors and four conscripted seamen in the lead ship, and two conscripted seamen in each of the eight boats running parallel. In addition two or three conscripted operators at a land station are needed. On account of their small crew the parallel boats themselves can be small and relatively cheap to purchase and maintain. Since the electronic positioning system keeps continuous check on the ship's course it has become possible to double the sounding speed, i.e. to maintain 15 knots. This method, however, does not permit the evaluating and recording of the data whilst underway. Consequently the echograms have to be collected afterwards and translated into depth figures on the plotting sheet. The new parallel-sounding method has meant an immense increase in the number of echograms, the manual processing of which would constitute a practically insurmountable problem particularly in the realm of recruiting draughtsmen. Inspection and drawing work of this kind is extremely monotonous and tiring, and this made it evident

from the outset that considerable staff problems would be involved. A large-scale turnover of staff would obviously be a great disadvantage in terms of quality. There is also a considerable risk of errors arising due to fatigue and to the tediousness caused by monotonous and repetitive work.

In other spheres automatic data processing has proved to be the only solution when dealing with very large quantities of figures. The possibility of using ADP for hydrographic surveying was closely examined at the Hydrographic Department, and it was very soon evident that in principle there were no insuperable problems in the application of data processing to echograms. The principal difficulties seemed to be connected with finding a work routine combining simplicity of procedure with dependability and clarity in the presentation of the results.

Preliminary discussions

In the Swedish Hydrographic Office data processing has been used for numerous routines in the fields of geodesy and cartography for some years now. For certain purposes the programmes have been worked out by our own staff, whilst for others the computations have been made with existing standard programmes. In other words, we have already had some experience of ADP. The first discussions on the evaluation of echograms by means of data processing were begun in the spring of 1961. With Mr. A. THUNBERG as leader of the project, the work was commenced in cooperation with Mr. B. LINDBLOM, of the Board's Department of Lights and Electrical Engineering, together with specialists on automatic data processing from the firm of Consulting Engineers, Nordisk ADB. The main object was to find a reasonable way of approaching the problem from the point of view of cost. Available economic resources were limited, and this meant that a number of alternatives that in themselves were interesting and attractive had to be discarded. Attention was firstly devoted to the question of how the echosounder data would be converted to digital form. Amongst other things was discussed the possibility of recording sounding figures from the echo-sounder direct onto punched tape or magnetic tape on board the surveying ship or boat. This procedure has since been developed, and is now being tested by the Finnish Board of Navigation.

However at the preliminary discussions of the Swedish Hydrographic Department it was decided that this alternative would be altogether too expensive, particularly in regard to parallel sounding, since each boat would require its own electronic apparatus either for punching the tape or card or else for transmitting the data to the lead-ship. It was also felt that there would be great difficulty in filtering out interference and irrelevant echoes from such things as for example fish shoals. Yet another argument against the direct collecting of digital data was that it would have to be recorded at short intervals as otherwise important information would be missed, particularly when sounding areas having an exceptionally hilly seabed and frequent narrow deeps. There would thus be a

large number of tapes, and it would take a long time to feed the digital material into the computer.

Accordingly a big reduction in the amount of data is very desirable, although the bottom profile on the fathogram must not be generalized too much. It will be another matter when echogram profiles can be recorded directly onto magnetic tape. The Finnish Board of Navigation has solved the problem of reducing the quantity of punched sounding data in a very ingenious manner: in an electronic storage unit which is coupled to the echo-sounder eight successive values are compared, and only the minimum depth in each group is punched. Yet despite this reduction the number of punched depth values is much greater than in the evaluation procedure where the bottom profile is described by a series of soundings selected by a trained operator. In many instances by this means the profile can be described quite satisfactorily through punching only two or three per thousand echo-soundings. To this should be added the important remark that the human eye is a good filter for detecting anomalies.

As a result of the consultations, in the spring of 1961 it was decided that the digitalization of the echogram's analogue data should be carried out afterwards on land.

What are the analogue depth data which have to be digitalized, i.e. translated into information readable by a computer? Figure 1 shows an example of a pattern where a two-range system is used for position fixing. In the same figure an echogram with the requisite annotations for position identification is also shown. The echogram records the seabed profile along the track of the ship or boat. In order that the depths registered along this track may be accurately entered on the chart, information is needed concerning both the geodetic position of the track and the positions of the individual soundings along this track. The track and the intersecting position lines are either straight lines, arcs of circle, hyperbolas or ellipses. The positions of the individual soundings along the track are found through interpolation between the intersecting position lines. These are marked automatically or manually on the echogram when the ship, or boat, crosses the intersecting position lines. In this way the echogram is divided up into short sections — usually about 300 to 500 metres in length — the position of each section being clearly determined. The echograms in figures 1 and 2 which refer to a two range positioning are from the first starboard parallel-sounding boat. A positioning instrument (Hydrodist) is mounted at each of the two triangle points 9 and 13. The distance from the lead-ship to these points can be measured accurately. In this particular case the track is shown as an arc with point 9 as centre. Measurements made in this way give a continuous check on the ship's position on its course, and this is a great advantage particularly when sounding in an area of uneven bottom and frequent narrow deeps, for here the courses of the surveying boats must be kept close together and no gaps are permissible. In the example in question four boats are shown as following a parallel course abreast the lead-ship and at a constant distance from it, two boats being to starboard (numbers 1 and 3) and two to port (numbers 2 and 4). Before starting a sounding course a printed panel on the echogram is filled in, showing the exact geodetic extent of the sounding

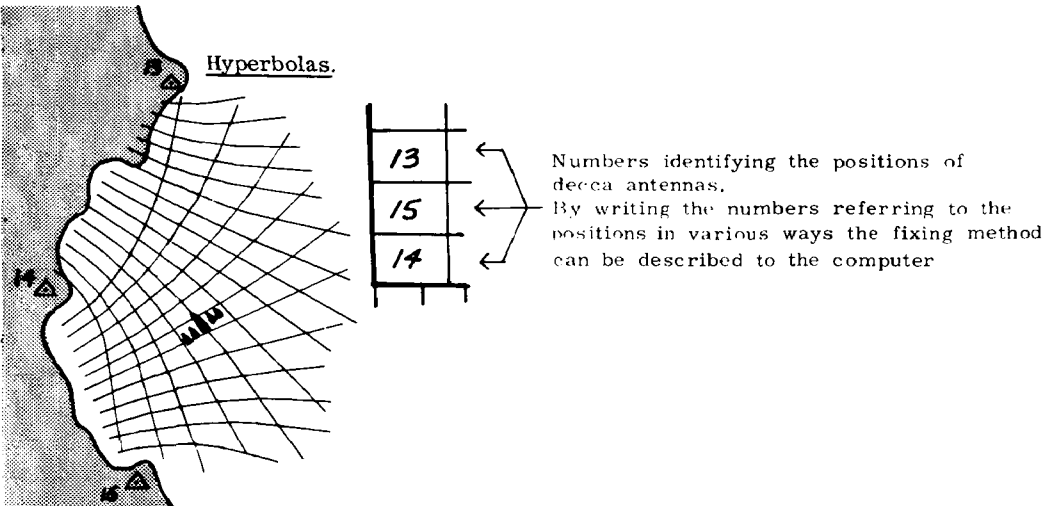
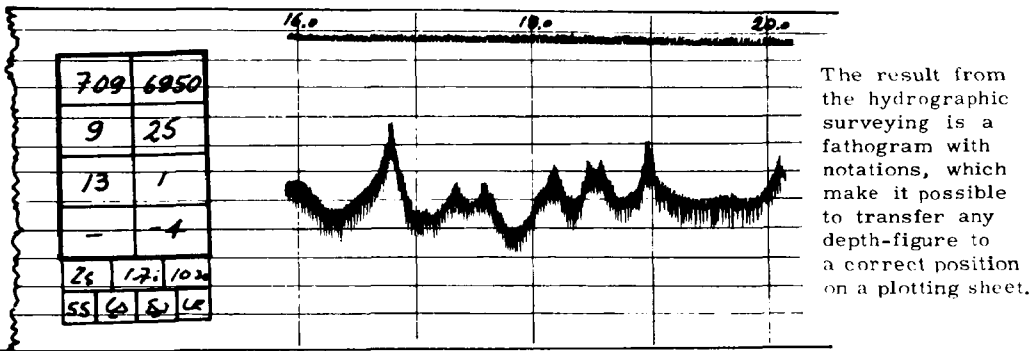
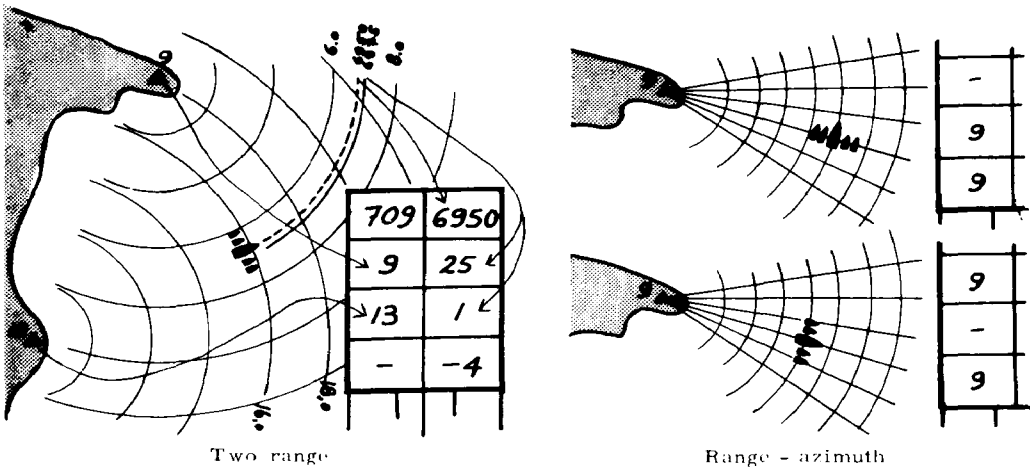

FIG. 1. — Some patterns of sounding lines suitable for Automatic Data Processing.

line. Data on the position lines intersecting the lead-ship's course are entered next to the traverse markings on the echogram. Below the stylized bottom echo profile in figure 2 is shown how the seabed profile is

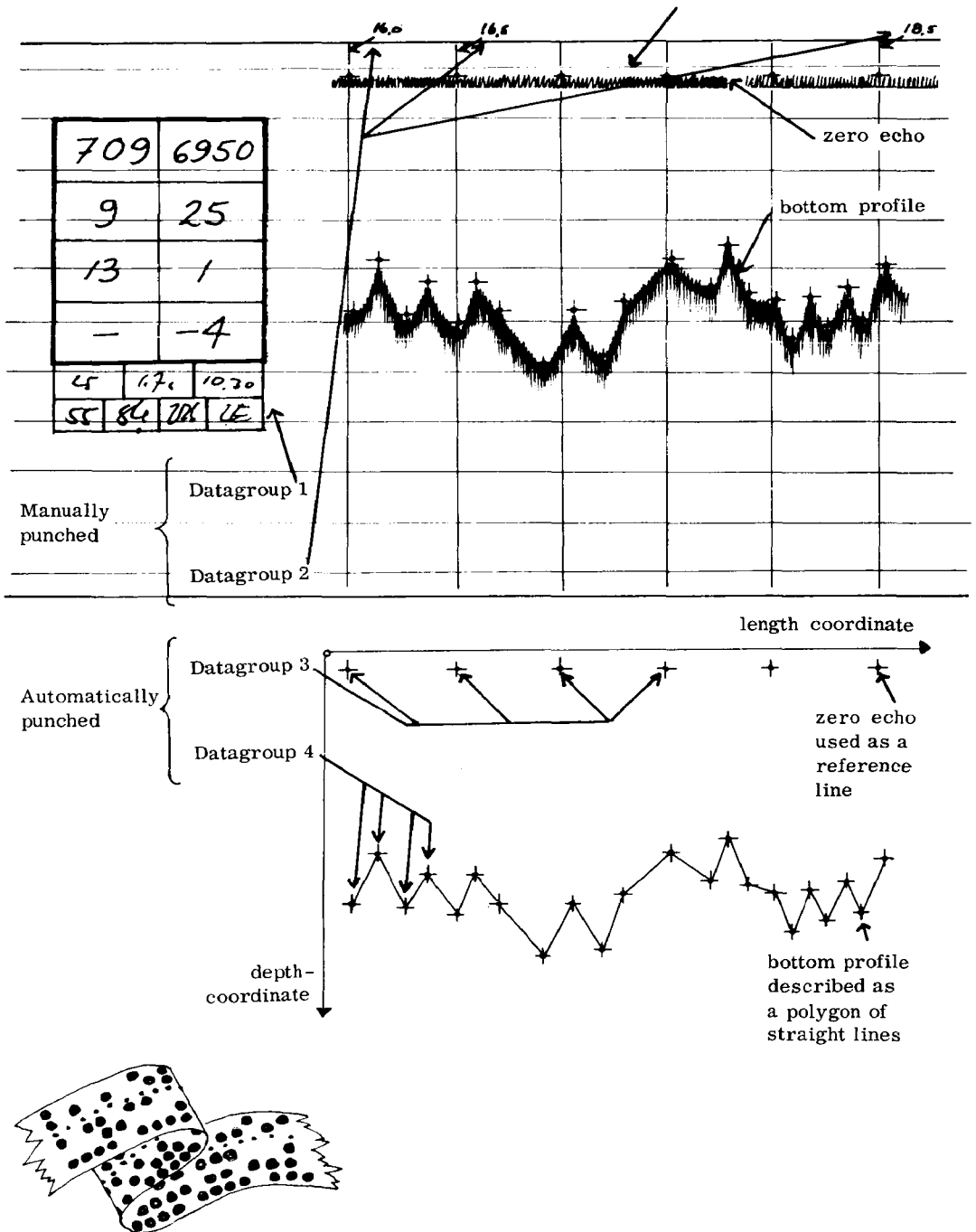
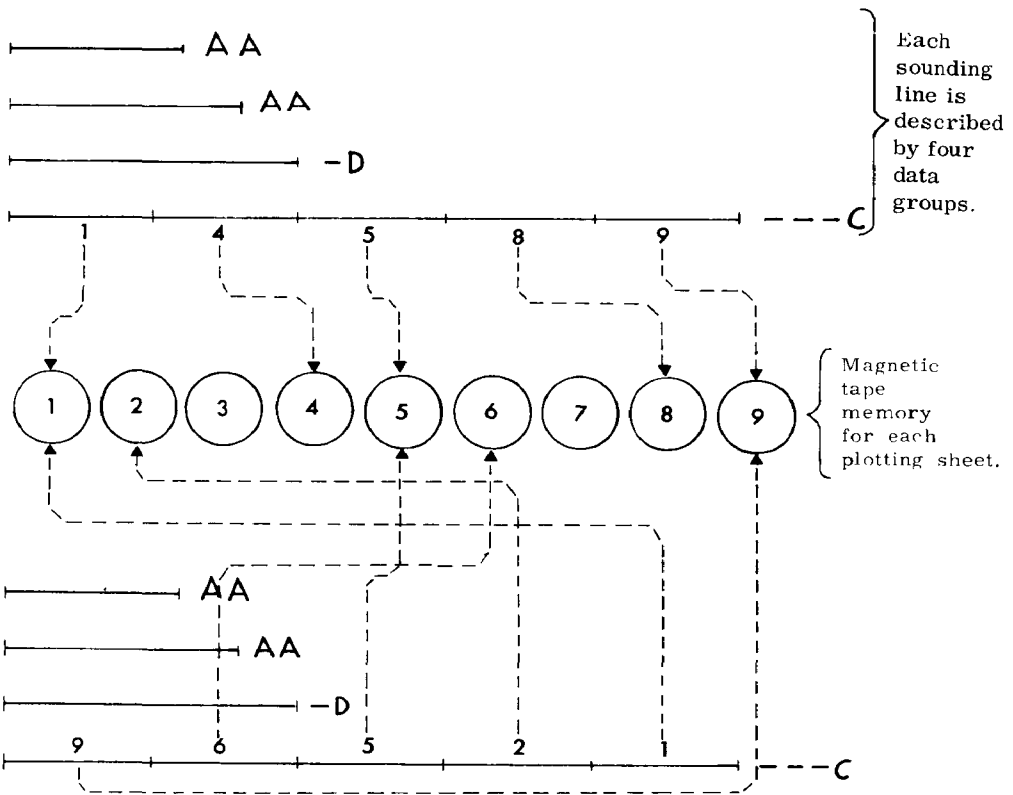
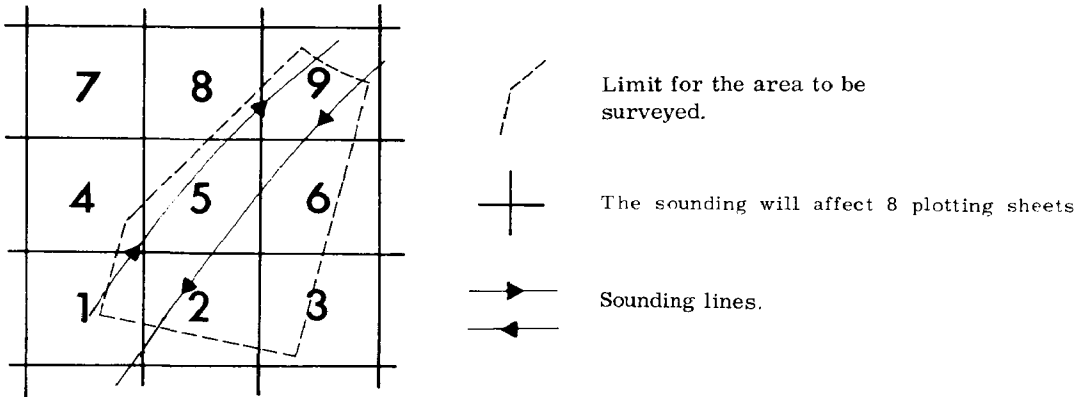

FIG. 2

approximated by a polygon line during the evaluation (digitalization). The black points with cross marks are those points which should be evaluated in order to obtain a satisfactory profile. A polygon line of this type is best



During the data processing the data concerning one sounding line is divided in parts, each concerning a particular plotting sheet and stored on a particular magnetic tape.

FIG. 3. — The editing of soundings being processed.

described by indicating the coordinates for the break points : (these will be called respectively depth coordinates and length coordinates). The coordinates are referred to the analogue-digital converter's axis system.

The line-printer out-put.

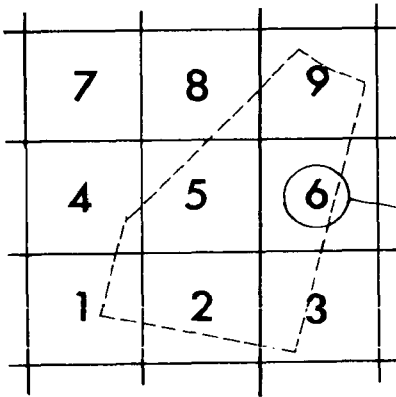

Each plotting sheet is divided in four squares.
Each square is divided in 100 x 60 small rectangles.

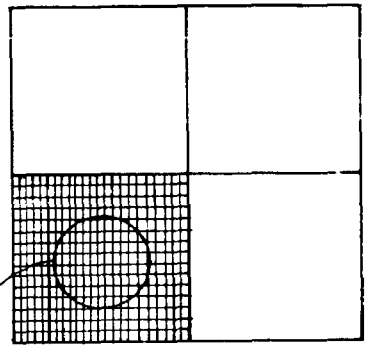

Only one symbol can be printed in each rectangle e. g. a figure, a letter or any other symbol available in the line-printer.

Two kinds of information are important :

- a) Depth contour lines.
The minimum value of a contour is printed if more than one depth contour passes the rectangle.
- b) Decimetre - and units of metre - figures are printed regarding the evaluated points along the bottom profile.

a,

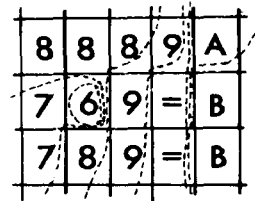

dm

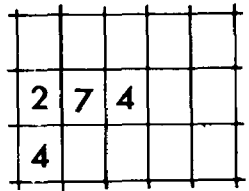

b,

Min depth within the 6 metre contour line is 5.7 metres.

m

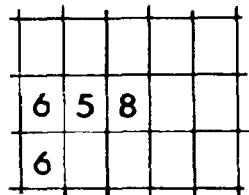

FIG. 4. — The line-printer out-put.

What then are the different stages of work leading up to the completion of the hydrographic chart? In the processing there are five individual phases:

- (a) Transferring the information on the echogram to the punched tape;
- (b) Examining the plausibility of the data punched on the tape by running the tapes through the computer;
- (c) Correcting any errors;
- (d) The final input of the punched tapes into the computer, and the storage of all surveying data on magnetic tape;
- (e) Editing and printing of lists of depth data by a rapid line-printer connected on line to the computer. These lists of data show the soundings in their correct position. (See figures 3 and 4).

Transfer onto punched tapes

After certain experiments it was found advisable to divide the information assembled on the echogram into four data groups (see figure 5).

Data group 1, consists of eight numbers from the echogram stamp, and is punched manually; it defines the survey project, describes the geodetic extent of the sounding line and gives the method by which the positioning is carried out (i.e. two-range, hyperbolic, etc.).

Figure 6 shows the impression of the echogram stamp. Since the 1966 surveying season the recording paper for the echo-sounder has this stamp printed on it.

Panel 1 identifies the survey project by means of a job number.

Panels 2, 3 and 4 are used for defining the position fixing method. The positions ashore for the hydrodist, the Decca antennae, etc., are determined geodetically and are given specific numbers. By placing these point numbers in different combinations in panels 2, 3 and 4, the method employed for positioning is described. By means of data processing, the machine programme through logical selection can itself select the appropriate subroutine for coordinate computing.

Panel 5 describes the track of the lead-ship in a parallel-sounding group (i.e. by the radius of a distance-circle or a hyperbole number).

Panels 6 and 7 are used for describing the position of the parallel-sounding boats in relation to the lead-ship. Panel 6 shows the boat's distance from the lead-ship, and panel 7 the position of the boat in the sounding sweep (odd numbers to starboard and even numbers to port).

Panel 8 is filled in afterwards and contains a correction for tide and transducer depth. In the early stages of the data processing it was assumed that the zero adjustment of the echo-sounder was always correct. In principle the recorder must be adjusted so that the zero echo on the echogram corresponds to the transducer depth. However it would be unreasonable to expect such a result always. Experience has also shown

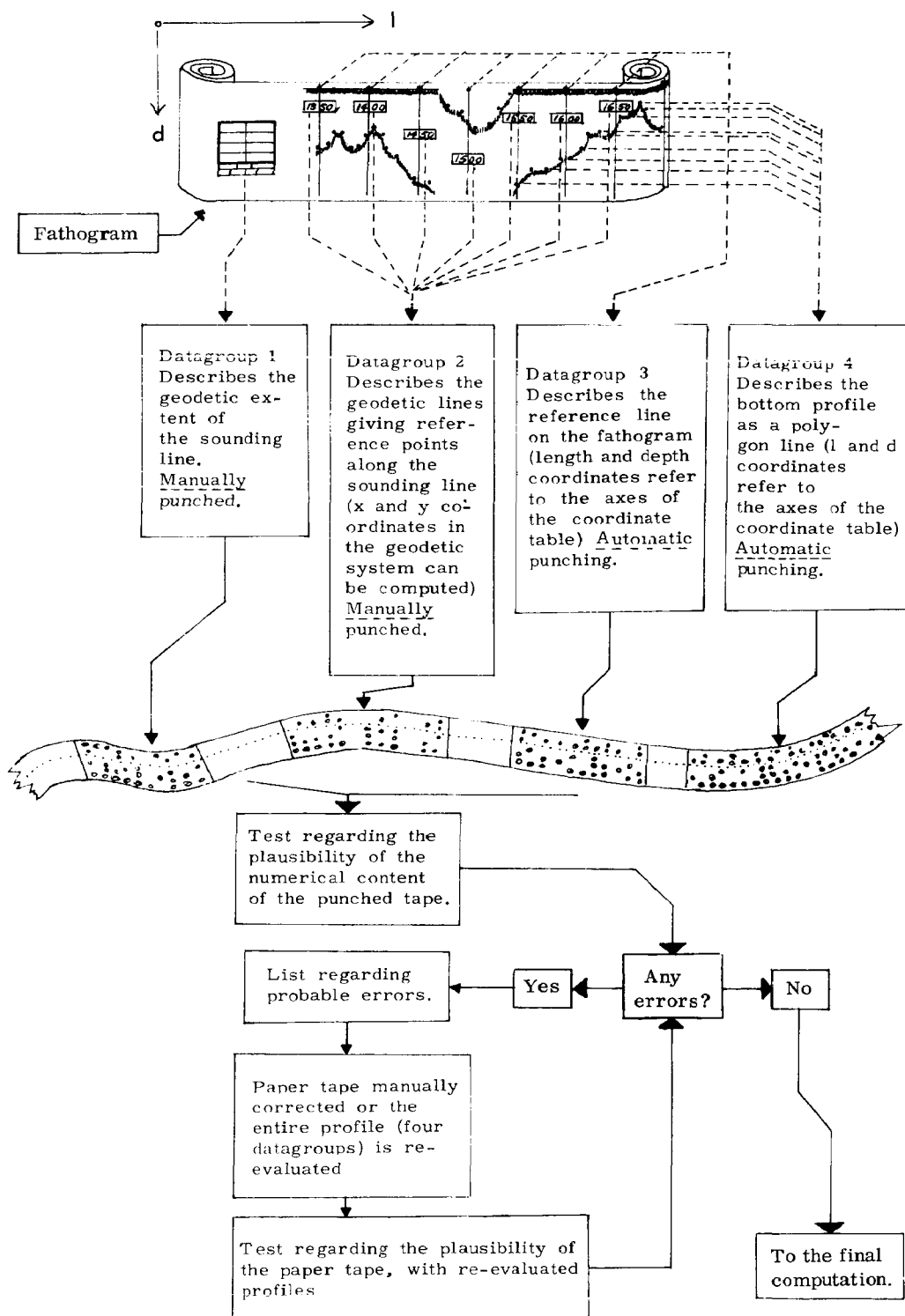

FIG. 5

1	AREA NO	MAIN SHIP LANE			5
2	GUIDING SLAVE	DIST. (metres)			6
3	CROSSING SLAVE	REL. POS. (No.)			7
4	DECCA MASTER	TIDE (+ or -)	TRANSD. DEPTH		8
		dm	dm		
	SURV.-RANGE USED		FREQV. USED		
	WIND/SEA	DATE	YEAR	TIME	
	SHIP/LAUNCH	SIGN.	CONTR.	EVALUAT.	

FIG. 6

that considerable deviations regarding the adjustment of the zero echo occur from time to time. Since the distance between the zero echo and the bottom profile represents the actual measured depth the zero echo can be used with advantage as a reference line. In this way it has been possible to dispense with the printed graduations on the record paper, because if for any reason the zero echo alters its position then the bottom profile follows.

Data Group 2 is punched manually and relates to intersecting position lines. If the intervals are of equal length all along the sounding course then it is sufficient if the operator punches the data for the first, second and last intersections only. Thus for the planning of the sounding work we endeavour to achieve regular divisions of the echogram all along the bottom profile. However there are occasions when it is necessary to deviate from this principle; for example if the sounding sweep has to alter speed. In the case of irregular divisions all the intersecting position lines have to be punched on the tape.

Data group 3 is punched automatically and describes a reference line on the echogram (normally the zero echo). At those points where the zero echo line is intersected by the transverse markings the evaluation table's mobile measuring mark is accurately set, and by pressing a button a pair of coordinates (length and depth), referred to the axis system of the evaluation table, are registered on the punched tape.

Data group 4 is also punched automatically and describes the bottom profile which is approximated by a polygon line. Each point is defined by a depth and a length coordinate, always with reference to the axial system of the evaluation table.

The depth at each individual point along the sounding line can now be easily calculated as being the difference between the reference line and the bottom profile depth coordinates. Corrections for tide and transducer depth are added to this difference in the further computations. (See figure 5).

Figure 7 shows a print-out from a paper tape with data regarding one sounding line.

PRINT OUT FROM A PAPER TAPE.

Data regarding one sounding line

Data
group

1	}	+ 782 . + 1500 + 1500 + 1216 + 25 + 1 -2 +5 AA	
2	}	+ 0480 + 0400 + 5660 AA	This "extra" figure is punched by the operator to give a second definition of the positioning method used.
3	{	+ 07578 - 00059 + 07826 -00057 + 08081 - 00056 + 08344 - 00056 + 08604 - 00057 + 08661 -00056 : 09124 - 00061 + 09390 - 00054 + 09648 - 00059 + 09918 - 00059 + 10171 -00060 + 10428 - 00056 + 10689 - 00056 + 10945 - 00058 + 11183 - 00058 - D	
4	{	+ 07613 - 03526 + 07848 -03430 + 07978 - 03361 + 08133 - 03324 + 08334 - 03341 + 08419 -03334 + 08467 - 03372 + 08481 - 03339 + 08678 - 03222 + 08805 - 03178 + 08829 -03205 + 08884 - 03137 + 08972 - 03152 + 09056 - 03086 + 09129 - 02852 + 09174 -02868 + 09210 - 02825 + 09234 - 02509 + 0924? - 02375 + 09256 - 02474 + 09268 -02416 + 09279 - 02445 + 09318 - 02021 + 09335 - 02002 + 09345 - 019?2 + 09365 -02008 + 09379 - 02110 + 09394 - 02290 + 09424 - 02350 + 09430 - 02278 + 09448 -02103 + 09468 - 02200 + 09490 - 01888 + 09506 - 01779 + 09532 - 01802 + 09553 -02046 + 09565 - 02174 + 09583 - 01949 + 09610 - 02063 + 09630 - 02169 + 09646 -02330 + 09667 - 02344 + 09705 - 02415 + 09714 - 02480 + 09733 - 02460 + 09750 -02452 + 09772 - 02514 + 09792 - 02591 + 09812 - 02732 + 09829 - 02801 + 09851 -02812 + 09882 - 02821 + 09895 - 02878 + 09914 - 02826 + 09920 - 02891 + 09935 -02829 + 09944 - 02880 + 09977 - 02826 + 10013 - 02821 + 10075 - 02744 + 10261 -02398 + 10281 - 02395 + 10382 - 02223 + 10414 - 02004 + 10424 - 02098 + 10510 -01920 + 10524 - 01748 + 10534 - 01812 + 10547 - 01680 + 10565 - 01754 + 10598 -01715 + 10617 - 01816 + 10656 - 01742 + 10665 - 01805 + 10882 - 01550 + 10889 -01616 + 10908 - 01575 + 10978 - 01530 + 11002 - 01389 + 11010 - 01485 + 11029 -01519 + 11046 - 01434 + 11065 - 01493 + 11083 - 01432 + 11102 - 01316 + 11123 -01383 + 11144 - 01308 + 11175 - 01239 + 11192 - 01132C	

Positive values in data groups 3 and 4 are length coordinates and negative values depth coordinates. The coordinates refer to the axes of the evaluation table and have been given different signs to make it possible to distinguish between depth and length coordinates.

Fig. 7

Test of the punched tape content for plausibility

When all the echograms relating to a particular survey project have been transferred to punched tape there will be material for further processing. The way in which the transfer has to be carried out does not permit double punching for content checking. It is possible, however, to make the punched tape content conform to certain requirements. The number of intersecting position lines in accordance with data group 2 must agree with the number of registrations in data group 3; the length coordinates in data groups 3 and 4 must always increase; in data group 1,

only a certain number of the position points will be quoted, etc. Thus with the aid of a computer the plausibility of the punched tape figures can be checked, and this requires very little computer time. This checking results in a line-printer list of presumed errors and the nature of the errors is also carefully described. The list could for example give the following information : " Tape No. 8, 12th sounding course, data group 3, number value 26 ", followed by comments on the character of the error.

All the data concerning the sounding courses involved are also assembled on a record. When all the tapes relating to one job number have been processed the sounding courses are sorted, and a complete list is obtained via the line-printer. Such a list makes it possible to check that all the echograms have been included in the processing. In most cases the indicated errors can now be rectified manually direct on the paper tape by means of a simple tool (a punch). If, however, this is not possible then an incorrect sounding course can be erased from the tape by manually punching special symbols on the paper tape. The echogram in question has then to be retransferred to the analogue-digital converter and the tape tested again (see figure 5).

Storage on magnetic tapes

After testing and correcting work the material is prepared for computer processing, the final result of which is a list of data where the soundings are printed (by a line-printer) in their correct positions. This list of data is used as a manuscript when the fair sheet is drawn.

The following are the phases of the work involved (see figures 3 and 4).

1. Determining the geodetic plane coordinates for the intersecting points of the sounding lines with the position lines. The computer itself selects the subroutines, based upon information in the data group 1, for determining the coordinates. Since the position lines followed by the sounding ship and boats are usually second degree curves, the computer programme has a sub-routine for inserting extra reference points along the profile so that the positions of individual depth figures can be determined through linear interpolation in the further computations.

2. Possible correction of data groups 3 and 4 for errors arising from the fact that the echogram has been inadequately adapted to the evaluation table.

3. Correction for tide and transducer depth.

4. Collocation of the computed x and y geodetic coordinates with the length and depth coordinates for the reference line and the bottom profile. There is a known numerical relation between the x and y coordinates of the transverse marks and the length and depth coordinates.

5. The division of each sounding course into parts, each constituted by all the data referring to one plotting sheet. The size of the plotting

sheets can be very varied, but these will always be square. The decisive factor here is that as the magnetic tape memory is limited only a certain amount of depth data for each plotting sheet may be stored. When processing material from an area where the general depth is not very great and where the seabed is uneven, and where in consequence the sounding lines must be run close together, the plotting sheet should cover an area of $2\,500 \times 2\,500$ metres for example. For sparser soundings however, at greater depths, the plotting sheet could cover perhaps 10×10 kilometres.

6. Storing the part-profiles on magnetic tapes, grouped according to plotting sheets. About 33 000 words of 40 bits are available for each plotting sheet. In the computer used only thirty plotting sheets can be processed at one and the same time. A certain number of plausibility tests are also carried out at this stage in the processing.

Drawing up and printing the plotting sheet manuscript

The topographic characteristics of the seabed which it is required to record are the general depth conditions, which can be indicated through depth curves, and also certain extreme values such as minimum and maximum depths. For these last greater accuracy in depth information is required. The evaluated breakpoints along the bottom profile in the fathogram consist mainly of such extreme values. Thus decimetre figures are generally present in the digital depth data available on the tape. The positions for different depth contours along the profile can be computed through interpolation.

In an earlier version of the data processing system a tape-guided plotter was used for printing the plotting sheet, but a large number of punched tapes was needed to guide the plotter and the punching of these tapes via the computer involved great expense. The plotting work also took both time and money. It thus very soon became evident that another method was needed. A rapid output device is the line-printer which prints 15 lines per second, and in which each line can hold up to 120 different symbols. If this could be used for printing the final results the cost of renting the computer would be reduced and the same time the time-consuming plotting work could be dispensed with.

The line-printer is typographically designed so that if 60 lines with 100 symbols per line are printed the result is a square of 255×255 mm. If every square plotting sheet were divided into only 60×100 small rectangles, the quadratic content of each area would be rather large. If for example the plotting sheet square covers an area 10×10 kilometres then each rectangle will cover 100×160 metres. As the line-printer cannot print more than *one* symbol in each rectangle the information which could be obtained from such a plot would be much too generalized. In order to attain the maximum resolution in the chart area it is important to divide up the plotting sheet into as many sub-rectangles as possible. This could be done by dividing the square plotting sheet into 4, 8 or 16 sub-squares then divided into 60×100 small rectangles. As all depth data belonging

to the plotting sheet are stored on one magnetic tape memory the tape could be read by the computer 4, 8 or 16 different times, each reading resulting in depth data regarding one sub-square edited on 60×100 possible places for depth information. On the other hand in order to save computer time it is desirable to carry out the work in such a way that information stored on magnetic tape need not be read more than once. If the computer used has a large core store capacity then we can afford to divide each plotting sheet into an adequate number of sub-squares, each one containing 100×60 possible places for information. The computer used by the Swedish Hydrographic Department permits the simultaneous editing of eight such sub-squares. Four of these sub-squares are used for editing data regarding the seabed topography, while the other four contain data for extreme values, e.g. maximum and minimum depths. In principle the extreme value lists should contain all the breakpoints which the punching operator has selected for describing the bottom profile on the fathogram.

This means that every plotting sheet is divided up into $4 \times 100 \times 60$ small rectangles (figure 4). The scale factor can be determined quite simply. If for example the plotting sheet covers $2\,500 \times 2\,500$ metres and each quarter plotting sheet measures 255×255 mm then the scale will be $1/4\,900$, i.e. very close to $1/5\,000$. Each small rectangle then represents an actual area on the sea bottom of 20.8×12.5 metres. Any of the line-printer's 63 different symbols can now be inserted in each rectangle. Through the optimal use of the core storage of the computer a total of 48 000 depth data figures per plotting sheet can be accommodated. Only in cases where the seabed is very uneven and the general depth is small need each small rectangle be filled in.

Certain checks of the data processing can also be made at this stage. It can happen, for example, that information for a small rectangle is derived from two different sounding lines, and in this case the soundings for insertion in the rectangle should of course be much the same; if, however, there is too great a divergence the computer produces a paper tape showing the nature of the error. Figures 8a, 8b and 8c show examples of line-printed plotting sheet manuscripts. Figure 8d shows the result after the contour lines and some depth figures have been manually drawn using line-printer tables as basic material.

If within a line-printed plotting sheet certain areas are of particular interest, and the resolution required is higher than is the case for a standard line-printed plotting sheet, then *it will be easy to enlarge to any scale any sub-square chosen within the limits of the plotting sheet*. As mentioned above, each enlargement will be divided into $4 \times 100 \times 60$ ($= 24\,000$) rectangles. The enlarged plotting sheet will be of the same size as the standard plotting sheet but of course at a different scale. If, for instance, one quarter of a plotting sheet is enlarged the scale for the line-printer plotting sheet will be twice that of the standard plotting sheet.

If during the processing it becomes necessary to exclude one or more sounding lines from the computations this can be easily done. If required, sounding lines may also be transferred to other positions, for example if data have been wrongly noted on the fathogram stamp.

TABLE ① (from line-printer) WITH SYMBOLS REGARDING DEPTH CONTOURS.

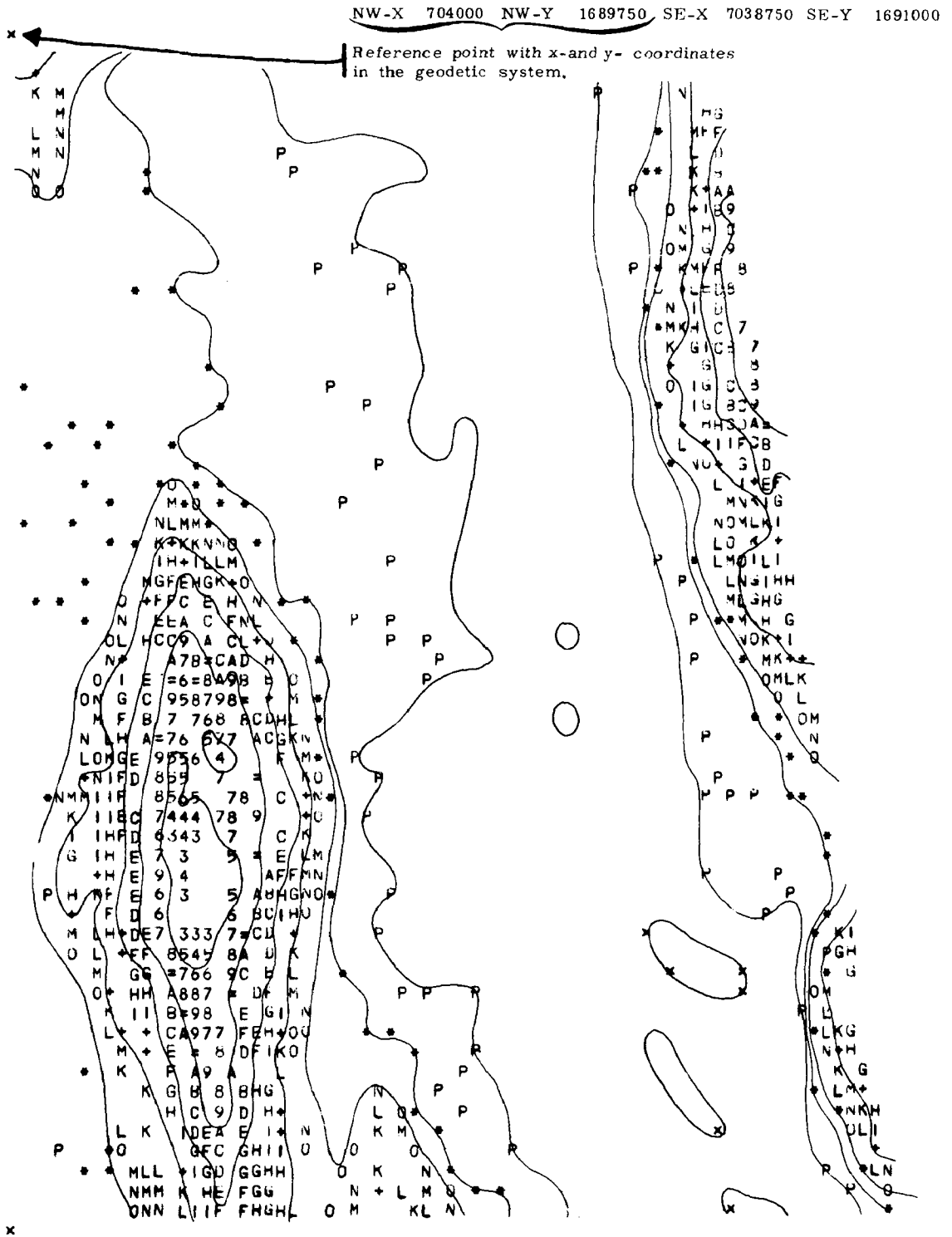

Fig. 8a

TABLE ② (from line-printer) WITH FIGURES REGARDING EVALUATED DEPTHS.

	NW-X	7040000	NW-Y	1689750	SE-X	7038750	SE-Y	1691000
					4 8			
9		3		3	3 3 9			
	2 2 33		3 3					
	2		3 3	3				U
		3 3 3 3	3			3 3		
	2		3 3 3 3 3	3		333 3 3 5		
	2	3		3		33		1
	2		33 3	3	3 3		2 1	
	2			3 3	3 3		2 4 9	
	2	2		3 3 3 33	3 3	3 3	2 7 88	
	2	2 3 2 3 3	3	3 3		3 3		
	2	2 3 2 33 3 33				3 32 2		
	2	3 2	3 3	3	33	2	3 7	
	2	2	3	3 3	3		793 6	
	2		3 3				21 9 2	
		2 3		3		33	6 277	
	2 222		32 3 333 3 3 3 3			3 229 6		
2	2	2 3	3 3	3	3 3	3 3	2 8 1	
	3		3 3 3 3 3 3 3 3				20 / 1	
3	2	3 22 3 3 3 3 3 3 3 3		3 3	3 3	3 3	8 1	
2	3		3 3 3 3 3 3 3 3			3 3	1	
	32 3	3	3 33 3	3 3 33 3	3 3	3 332 22		
	2		3 3 3 333 33	3 3		3 3 2 4		
	32 2 3		2 2	3 3		3 3	2 4 1	
	3 3	2	2 3	3 3 3		3 3	3 3 2 4 1	
3	3 3	98 2	2 3	3	3	33 221		
3	2 2	6	2 3	3 3	3	3 1 8		
	2 0 5	84 2	3	3	3	32 167 6		
	2	5	4	2 3 3	3 33	33		
	2 2 934 7			3 3	3 3	3 33		
	2	7 17		2 3 3	33 3	3 33 3	00	
	0 7	9	5 22 3 3		3		32	
2	2	2 57 97	2 3		3			
	0	7 77 3 1 3 3			3 3	3 3 3 3 3		
3	32 5	4 476 0 60	3 3			3 33		
		5 84 4 6 602	3			33	32	
2	2	4 54 54 3	5 3 3333		3 3	3 3	2	
3		286 7465 6 9 3 04	33	3			3 22	
		8952 8 3 7 0 2 9 2	3			3 3		
		8854 52 3 78	U	3 3 33 3		3		
3	7	7 6 9 2 8 04	3 3 3 3 3	3		3 3		
	7 07 5 8 5 2 4		2 33 3	3		3 3 3		
3	3	5 4	2 4 1				333	
3	3 9 15 6 5 2	5 3	3 3	3			3 3	
3		03 72 2 8	1 23 3		3		3 3 9	
	2 2 66	8			3		3 36	
	2 49 7	765 833		3		4		
	2	797 9 4	3 2	3 3		4	3 466	
3		9	1 8	8	3 3		3 1 6	
3	332 2 9	86 0	2 33		3 3 3	3 3 3		
33		0 9	359 22 2	333		33 4 3 3	2 0 6	
	3 23 0	0 80		2	3	3	33	
	2 2 1 7	7 58 2	2	3 3 3		4 3 34 3 2 2		
	2 23	5	4	2 3 3			3 3 8	
	24	1 6 2 68 0		3			3 2 0	
3		21	2 7 9	4 2 0 2	3		3 0	
3	3 3 3		0 7	5	4		3 4 3	
3	3 3 3		9 4 566713	3 2	4	3 3 3	4 3 3 3	
3			999 5	4 3 9	2	2 3 3	3 3 3 3	

Fig. 8b

TABLE 3 (from line-printer) WITH FIGURES REGARDING EVALUATED DEPTHS.

	NW-X 7040000	NW-Y 1689750	SE-X 7038750	SE-Y 1691
6			5 5	
	9 6 23		1 0 0	
7		4 4		0
	0 2 1 3	4 6		0 6
6	8	4 4 4 4 5	5	352 0 4 8
7	1	3	5	50 6
7	12 2	3 65	8 7	6 0
7	9	3 5	7 7	8 3 9 8 0
6		2 3 6	7 7 66	2 3
7	8 0 8 0 0	5	5 8	7 5 8 1 71
8	9 0 9 12 1 22			4 2
7	1 9 2 2	4	6 56	3 49 8
9	9 0	1 3	7 7	6 9 7 3
8 978	2 29 1 111 3 3 4 4			5 83 5 1
8 7	9 1 1 2	6	7 8	44 7 422
1	0	5	5	4 992 1
9 0	9 1 99 1 1 3 2 3 4 6	6	8	6 5 6 7
9	09 0 0 4 23 2 3 3 4 5 45 5	6 7	6	82 8 2
	0 3 4 312 33 5			7 2 5
09 9 3	6 6 5 4			6 219 76
9	2 1 2 3 3			5 2 7 2
0 1	14 3 9 2	4	6	8 1 6 9
0 9 9	8 6 1 4 4 7	7	7	7 2 7 4 1
	5 1 3 11 8 2 4 4 77			54 972
8 5	334 2 7 2 4 4	6 5	6	3 6 6
9	4 78 1 99 1 5	57 7	6	53 6 33
8	6 3 0 7 0	7	7	6 44 2 36
8	5 23 18 7 0			5 28
8	8 6 67 2 3 0 4	7 5	8	5 4 12 0
71 3	3 105 8 45 4 6			3 12
	3 78 9 8 238 0			44 08
8 5	0 64 88 8 1 1 4575	7 8	4	1 9
1	761 4864 5 6 0 00 66 8			1 77
	1809 9 4 2 4 5 9 8 6			6 6 5
	2359 66 0 12 2 6 7 66 7			8 4
3 0	7 7 0 6 4 76 3 7 7 6 8			6 3 5
6 01 8 3 1 4 4	9 34 5 8	7		6 3 5
2 5	7 5 4 3 2			332
1 6 13 7 1 2 5 0 4 6		6		6 2
3	23 81 7 3 2 91 3			7 8 0 0
6 1 86	4	8		9 55
5 21 3	704 392			0
6	780 9 5 9 9 3 4			0 8 714
2	5 9 4 5 0	8 8		8 2 4
3 138 7 7	38 9 8 01			8 7 9 9 8 7
22	3 9 950 56 8 445			78 1 9 9 7 0 4
	0 72 7 2 45 8	6		97
9 8 5 4	6 23 4 6 5 4 8			1 8 81 7 9 7
8 73	3 1 0 4 6			2 2 2
84 1	3 8 05 2 2			9 2
3	64 6 1 4 9 5 4 2 4			4 4
3 3 0	0 7 0 1			9 1 9
5 0 1	6 8 167648 6 0 1			9 0 8 7 8 3
3	010 6 3 4 8 9 9 6	8 9		18 86

FIG. 8c

DEPTH CONTOURS AND DEPTH FIGURES.

Figures only where necessary for the completeness of the chart.
The drawing is based on the line printer output.



FIG. 8d

Figure 8e carries the legends for symbols used in the line-printer output.

Explanation of TABLE ① (from line-printer) with symbols regarding depth contours.

Depth	1- 25 metres.	1 m interval.
"	26-100 "	5 m "
"	101-300 "	25 m "

Explanation of TABLE ② (from line-printer) with figures regarding evaluated depth from the bottom profile

Depth less than 25 metres. The printed figure stands for the value of the unit of metres.
(Depth = 16.4. 6 is printed)

Depth more than 25 metres. The printed figure gives the value in tens of metres.
(Depth = 47.5. 4 is printed)

The main depths are given in the table using symbols for depth contours.

Explanation fo TABLE ③ (from line-printer) with figures regarding evaluated depths from the bottom profile

Depth less than 25 metres. The printed figure gives the the dm. value
(Depth = 16.4. 4 is printed)

Depth more than 25 metres . The printed figure stands for the value of the unit of metres.
(Depth = 47.5. 7 is printed)

The main depths are given in the table using symbols for depth contours.

SYMBOLS used when printing manuscripts for drawing of depth contours.

1	=	1 metre
2	=	2
3	=	3
4	=	4
5	=	5
6	=	6
7	=	7
8	=	8
9	=	9
=	=	10
A	=	11
B	=	12
C	=	13
D	=	14
E	=	15
F	=	16
G	=	17
H	=	18
I	=	19
+	=	20
K	=	21
L	=	22
M	=	23
N	=	24
O	=	25
*	=	30
P	=	35
x	=	40
R	=	45
=	=	50
S	=	55
+	=	60
T	=	65
*	=	70
U	=	75
x	=	80
V	=	85
=	=	90
W	=	95
%	=	100
X	=	125
Y	=	150
Z	=	175
%	=	200
O	=	225
=	=	250
U	=	275
%	=	300

FIG. 8e

The analogue-digital converter

Certain difficulties were experienced in getting hold of an analogue-digital converter which would fulfil the requirements of the Hydrographic Department which were as follows :

1. The apparatus must be easily transportable, and it must be possible to use it for field work if required.
2. The operator must be able to seek new breakpoints on the echogram profile immediately after having given the punch command, and while the punching of the preceding value is going on. This requires a storage function capacity.
3. It must be perfectly clear from the analogue data (the echogram) by what means the surveying points were selected during digitalization.
4. The number of recordings made per echogram must be easily countable for use in work studies at a later date.
5. The resolution in the analogue-digital converter should not be greater than what is reasonable in relation to all the other factors affecting the accuracy of the echogram profile.
6. It must be possible to place the echogram on the coordinate table without too great a necessity for accurate adjustment.
7. The echo-sounders are used for different depth intervals (0 - 50 m, 50 - 100 m, 100 - 150 m). Thus in the converter it must be possible to add the requisite depth : 50 or 100 metres. It was evident that at that time there was no suitable analogue-digital converter on the market at a reasonable price. Consequently we had to design our own apparatus, using the electronic equipment available on the market at that time.

There are in principle three different types of converters : (a) pulse-counting instruments, (b) mechanisms equipped with binary-coded discs or photo-electric converters, and (c) precision potentiometers, the voltage of which is read off on a digital voltmeter, whereupon the signal is recoded in binary form.

Alternative (c) proved fairly simple to follow, and the cost of building an evaluation apparatus according to this principle seemed reasonable. It might appear circuitous to transform analogue data (presented graphically) to another analogue form (voltage) for digitalization, but in practice this has functioned quite well. The principle is used in many commercial analogue-digital converters. During the last two years Dobbie McInnes Ltd. of Scotland, amongst others, have designed an analogue-digital converter — a coordinate reader — whose performance is adequate for most purposes connected with the digitalization of echograms.

The analogue-digital converter built by the Swedish Board of Shipping consists of a coordinate table fitted with a conveyer for a carriage along the echogram (see figure 9). This carriage carries a smaller carriage which moves vertically. A ten-revolution precision potentiometer is attached to the larger carriage. This potentiometer is driven by a wire and a pulley-wheel. A three-revolution potentiometer is attached to the smaller carriage



FIG. 9

which is rack and pinion driven. In a second digitalization apparatus the wire and rack and pinion system has been replaced by a more efficient transmission — a cogged belt of reinforced plastic. The demand for potentiometer precision has been set somewhat higher than the degree of precision (± 0.2 mm) with which the operator can set the measuring mark or visually read the sounding. A plexiglass sheet with a measuring mark has been mounted on the smaller one. In the new apparatus an illuminated measuring mark is projected onto the echogram. The two carriages on the coordinate table are mechanically directed in the same way as the rulers on a large drawing board, so that there is practically no risk of obliqueness. On the smaller carriage there is also a marking device which makes a black dot on the echogram 7 mm above the place on the profile being evaluated. This makes possible a later check on how the evaluation is carried out.

The number of evaluated points per echogram can be recorded in a counting device (call-meter) on the coordinate table. Also coupled to the coordinate table with its potentiometers is an electronic apparatus which handles the measuring, storing and punching of the values on the five-channel tape.

The equipment consists of :

1. Digital voltmeter. Solartron, with condenser storage.
2. Encoder. Solartron.
3. Programmer (designed by Solartron, Stockholm).

4. Tape punch (Creed 25).
5. Keyboard for manual punching.
6. Phase selector for addition of specified currents, depending upon the range in which the echo-sounder is used.

Comments

1. The Solartron LM 1010 digital voltmeter works rapidly and makes 60 measurements per second. Input impedance is very high (1 000 megohm), so that it can measure voltage on a condenser without any noticeable leakage.

2. The Encoder register contains 53 bits, and this permits the punching of two 5-figure numbers with symbols, as well as space for storage of a sexagesimal symbol. In this case, this symbol is used in such a way that the symbol for the carriage-return (i.e. a new line) is automatically stamped on the tape after each fifth pair of coordinates. This makes it possible to write out the tapes easily in an automatic typewriter in order to check the contents.

3. The programmer punches the above-mentioned carriage-return symbols and, among other things it also guides the measuring and punching cycles. Figure 10 shows a schedule describing the programmer function

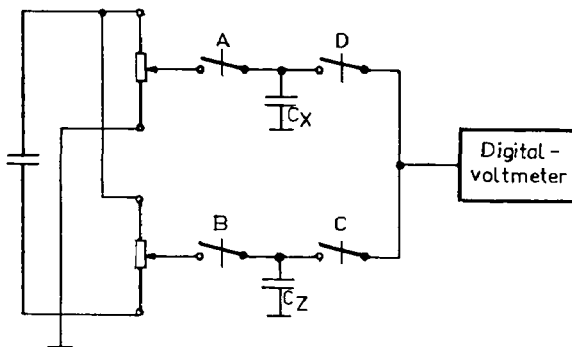

FIG. 10

that makes it possible for the operator to set the next measuring point while the punching of the coordinates for the former one is still going on. While the operator sets the measuring mark for the first point on the echogram all the contacts are open. When the scanning is to take place contacts A and B are closed. The analogue voltages are stored in the C_x and C_z condensers, after which the A and B contacts are opened. D is closed, and the C_x voltage is fed into the digital voltmeter and is punched. D is then opened and C closed, whereupon the C_z voltage is fed in and punched. When the A and B contacts have been opened the voltage in the r and z potentiometers can be changed without affecting the previous measured value.

4. At a punching rate of 25 symbols per second the Creed punch can easily complete the punching of 12 symbols (13 every fifth time) before the operator has had time to move the measuring mark to a new point.

5. For manual punching an electric typewriter is coupled to one of the Department's two apparatus, and this makes it possible to check the punching visually at once. A Lorenz tape-reader has been attached to this equipment so that when required a copy can be taken from the tape and duplicates of the new tape can be made. A keyboard unit has been attached to the other analogue-digital converter. Experience has shown that the error percentage in manual punching is very low, despite the absence of a written-out text.

6. An Atlas Monograf sounder is used for the sounding work. This functions in three different ranges of depth: 0 - 50 m, 50 - 100 m and 100 - 150 m; by altering the ratio these can be changed to 0 - 100 m, 100 - 200 m and 200 - 300 m. This was borne in mind when the Department's digital converter was designed. By a system of precision resistance, voltage corresponding to 50 and 100 metres can be added to the voltage derived from the coordinate table on the depth potentiometer.

Checking the functioning of the analogue-digital converter

Great functional reliability is of course required of the analogue-digital converter, and consequently it is essential that the entire transfer procedure from the coordinate table to the punched tapes is checked at regular intervals. This checking takes place as separate operations for the length and the depth coordinates. The linearity in the potentiometers is checked, and also the punched symbols are checked for errors when processing data from such control measurements.

The electronic apparatus and the tape punches are subjected to a complete overhaul after a certain number of hours of use. The number of hours the apparatus has been in use, together with details regarding its functioning, are recorded in an instrument log.

Concluding remarks

As already mentioned, the working group was not set too distant a goal on the question of how to apply data processing to hydrographic surveying. It seemed better to set up a system which might start to be used within a shortish time, and which could thereafter be extended to include further steps towards a fully automated system.

Data from a hydrographic survey (depth, time, position, etc.) may be sampled along the sounding lines and automatically stored on magnetic tape during the survey. Thus the basic material on magnetic tape will consist in the Swedish application of ADP of nothing except what is stored on paper tape. There will probably be no difficulty in inserting an automated

system for collecting sounding data into the programme system. With the profiles as basic data, a detailed list of sounding information in tabular form can be edited in the computer. At present these lists are printed-out as tables via a line-printer, but the thousands of soundings which go to build up this list could be the foundation for drawing up the depth contours automatically. This would probably be very intricate to programme, especially when a rugged bottom topography allows different interpretations.

In the very near future we shall have to change from the rather old computer we now use to a modern one, for example to an IBM 360. The entire ADP system will then of course be scrutinized and probably revised. There is however nothing to indicate that we shall depart from the main principles, although perhaps the analogue-digital converter will have to be reconstructed to write on magnetic tape instead of paper tape. Perhaps the T.V. screen on a modern computer could be used to present the results. Further studies will show whether or not this is realisable.