

AUTOCARTA FOR HYDROGRAPHIC SURVEYING

by Colin G. McQ. WEEKS,
Decca Survey Systems, Houston, Texas

This paper was originally prepared for delivery to an invited audience from the Royal Navy on 4 April 1973 at Torquay, England.

INTRODUCTION

This article presents a new surveying tool, Autocarta, which has been developed by Decca Survey Systems, Inc., Texas.

Autocarta X (see figure 1) is a tool for surveying and it should be judged as such. Information goes in, it is processed, and it comes out in the form of a chart, identical to a hand drawn chart except that the figures are perhaps more consistent. It does admittedly contain a computer, just as a body contains a brain, but the computer is not the be-all and end-all. It is a part of a system and the system stands or falls as a whole. I would suggest that it is not the surveyor's business whether the computer word contains 12 digits or 16, nor whether it completes an operation in 3 microseconds or 300 nano-seconds. The surveyor's concern should be with the end product, the chart, and whether it meets his standard of completeness and accuracy.

There are, I believe, three principal questions which come into a surveyor's mind when faced with new equipment of this type. The first, of course, is 'how will this be of benefit to me?' Then, when convinced that it will either save him money or allow him to obtain greater output from his resources, he will need to satisfy himself that the accuracy of the system is sufficient for his requirements. Finally, he must consider whether the operation and maintenance of the system is within the capability of his existing grades of personnel. These are the questions that I shall attempt to answer in this paper.

In its hydrographic application Autocarta operates in two modes, on line and off-line. In the on-line mode (see figure 3), inputs are obtained from the positioning system and the depth sounder. Depths are checked for validity, edited, allied to x-y positions converted from the hyperbolic or circular position values, selected to the scale of the survey, and output on to an intermediate tape, which may be either paper or magnetic. The

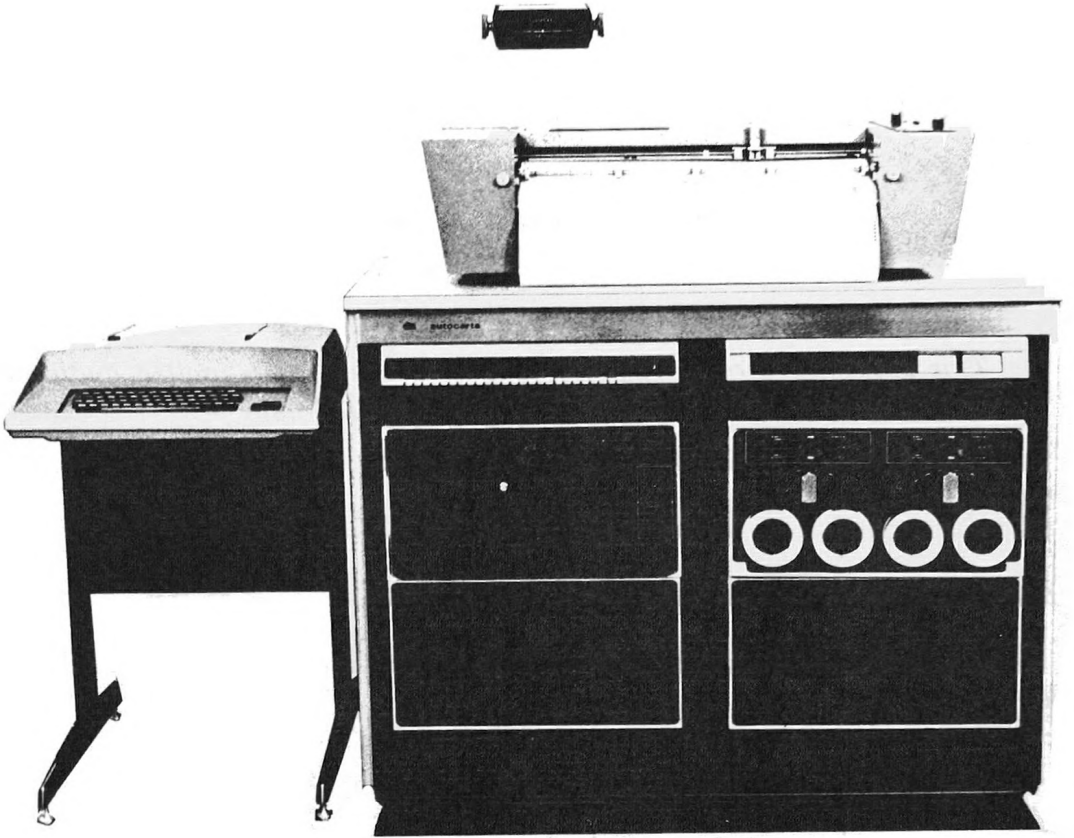

FIG. 1. — Autocarta X.

position input may come from any landbased positioning system — either hyperbolic or circular, provided that it has a digital output — with the probable exception of Omega. The depth input may similarly come from any depth sounder that has a digital output.

At the end of the day, when the tidal values are available, a different program is put in the computer, the tidal reductions are entered through the keyboard, and the intermediate tape is run back through. (See fig. 4). The computer then draws the reduced soundings on the plotter and simultaneously punches a record tape for transfer to a data centre. During this phase the positions could if required be recomputed, with monitor corrections applied to the original position values.

BACKGROUND

It might perhaps be useful if I first describe briefly the surveyor's work for those who do not have a hydrographic background.

The normal day falls into two parts. During the first the surveyor is away in a boat, or watchkeeping in the ship, collecting data. Positions

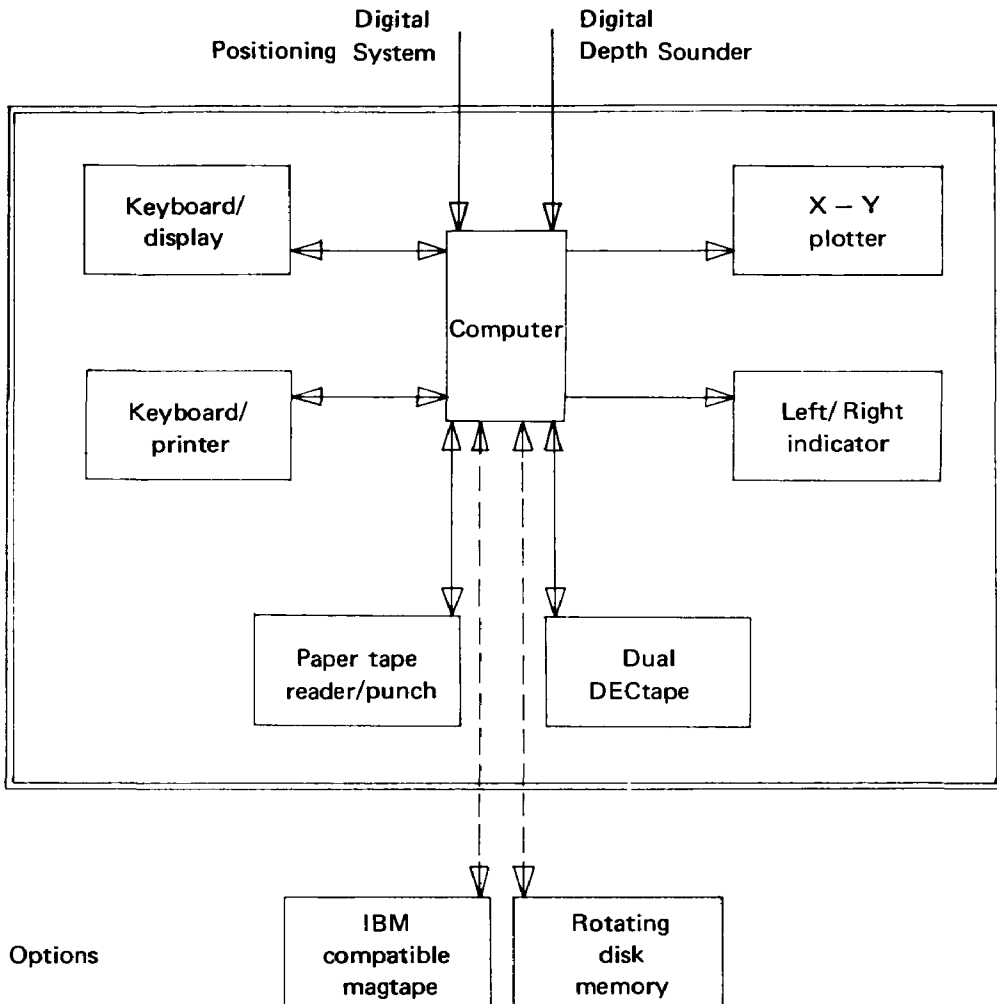

FIG. 2. — Functional diagram of Autocarta X.

are recorded at regular intervals, cross referenced to the echosounder trace, and plotted on the chart. This phase lasts from seven or eight in the morning until five or six at night. Then the boats return, the ship anchors, and the surveyors retire to the chart room for the second phase, inking in. This usually requires two people, one reading soundings off the echosounder trace, reduced for height of tide, while the other draws them in by hand on a transparent overlay of the fixes plotted during the day. The duration of this task will vary with the scale of the survey—but it is commonplace to find surveyors in the chart room up to 10 or 11 at night.

This is broadly the pattern of a Royal Naval surveyor's day and of course is not quite the same for the Port Authority surveyor or the commercial contract surveyor—but the same work has to be done. Data has to be recorded, edited, reduced and plotted. It is to assist in these necessary but tedious tasks that Autocarta has been developed.

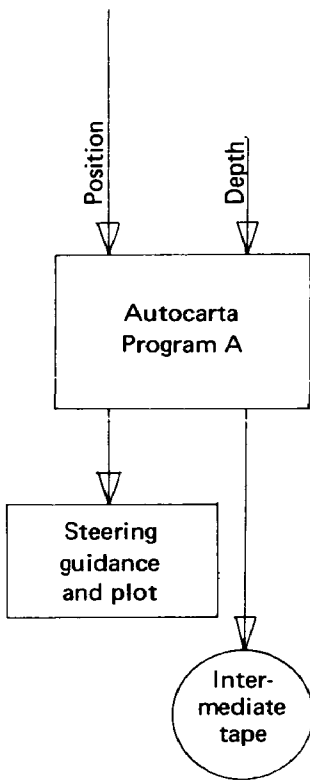

FIG. 3. — Online mode.

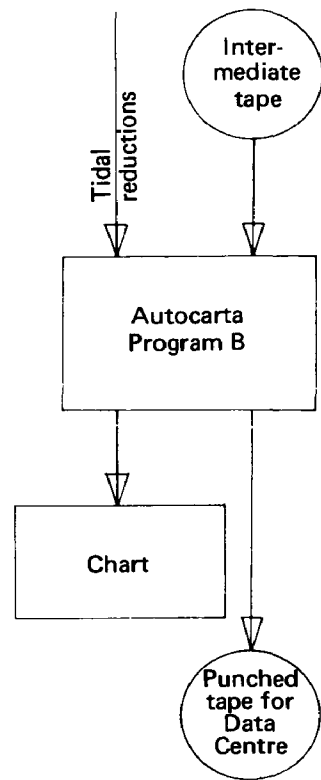

FIG. 4. — Offline mode.

THE ECHOSOUNDER

Before we go into Autocarta itself let us look a little closer at what the echosounder does for us. A typical trace would show the seabed something like figure 5, where the sawtooth effect is normally caused by

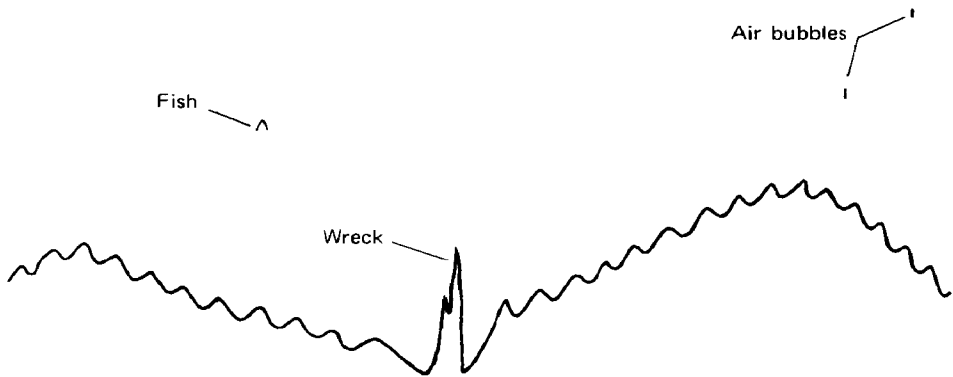

FIG. 5

the rolling and vertical motion of the vessel. The surveyor will normally draw a mental median line through those jags in order to reduce the effect of that particular error. The echosounder recorder faithfully records every echo which returns to the transducer, so that in addition to the seabed we get reflections from fish, wrecks, bits of garbage, seaweed and air bubbles in the water, which we can call in general false echoes.

In between the depth sounder and the computer there is an interface device, a digitizer. This is not included in Autocarta as the choice of model and manufacturer will depend largely on the echosounder rather than on the computer. These digitizers normally include either logic or gating circuits to exclude false echoes, but we cannot expect them to be 100 % successful. For argument's sake let us say they will be correct 99.9 % of the time.

It should be remembered that false echoes will almost invariably be shoal soundings; that our sounding selection will inevitably draw on the shoal soundings first; and that in a ten hour working day we have obtained 360 000 soundings, at 10 soundings a second. We allowed the digitizer to be in error one time in a thousand, so it has given us 360 false soundings, of which we might expect some 300 to appear on the chart, were we to do nothing about it.

Let us digress for a moment to explain the problems which might be caused by just one false shoal sounding. Let us say it is just 4 feet shoal and in a major fairway, and let us assume first that the surveyor noted it for examination. If it was at a distance from his area of work he could well waste half a day in steaming there and back and in running the very precise lines necessary to examine the area thoroughly. If there was a large range of tide he might well not be certain that it was a false echo until the soundings were inked in. Half a day for a survey ship at £2000 a day is expensive — and that was only one of our 300 false soundings.

On the other hand the surveyor may not examine it — as this may be an area known to change or it might be a sounding only 2 feet shoaler than an adjacent sounding. The chart then goes into the office where the shoal is noted and a dredger is sent out — and dredgers cost a lot more to run than survey boats. Or again the chart might well be sent to Taunton where that shoal will inevitably find its way onto the Admiralty chart. Then the big tankers come in more lightly loaded or even perhaps avoid the port altogether. Seven years ago each additional foot of draught was worth £25 000 a year to a supertanker — and it is probably much more now [1].

So we must endeavour to ensure that these false echoes do not reach the chart. To the surveyor, with his experience and reasoning power, this is really a problem — though on occasion even he is in doubt — but we are dealing with that idiot child the computer, that can only add and subtract, and we have to teach it to be equally discriminating.

We have first to face a dilemma. If we program our system to eliminate — or at least reduce — the number of false echoes, we shall inevitably reduce our chances of detecting wrecks. If we insist on the

system finding all wrecks then we equally inevitably will find so many erroneous shoal soundings on the chart that we shall spend all the time we have saved in running those errors to earth.

The answer, I suggest, is to attempt to eliminate all echoes that do not come from the seabed, and to require the surveyor to make a visual inspection of the trace to find the wrecks.

The way in which we determine visually whether an echo comes from the seabed is by comparing it with the echoes preceding it, because we know that there is a maximum slope which any given seabed material can maintain naturally. When we attempt to do the same thing on a computer we follow exactly the same procedure. We compare every value received from the digitizer with its predecessor, and if this difference exceeds a given amount, which the surveyor may vary, depending on his speed and the nature of the bottom — then we throw that sounding out.

Now I am going into this in some detail because I want to make what to me is a vital point — if we expect the computer to make as good a job of selecting soundings as the human eye, then we must give it the same information to work on. This may sound a reasonable statement; however it leads us straight into a very practical problem. The echosounder takes ten soundings a second, 360 000 soundings in the course of a ten hour day; and depth is useless alone, so we must also include time and position, though not necessarily for every sounding. By any standard this is a vast amount of data, either to record or to process.

Previous developments in hydrographic automation have followed one of two paths; the great majority of work has been done with data loggers, in which the data is recorded on paper or magnetic tape in a form suitable for entry to a shore computer. There is however an increasing trend towards the use of a computer on board ship and I believe this trend will continue. Whichever route they have followed however the designers have been forced to make an arbitrary reduction in the bulk of data by use of a sampling technique, so that soundings are dealt with, say, once per second, once every five seconds or once every ten seconds.

Autocarta is unusual in a number of respects, but the one in which I believe it is currently unique is that the computer looks at every sounding that is taken.

Figure 6 shows the effects of a sampling technique on our sounding selection. First we have missed the peak of a shoal, which could be vital if it happens to lie in a main shipping channel. Secondly each sounding may be half a metre or so different — either plus or minus — from that which would have been selected by the surveyor, since there can be no compensation for short period rolling and swell. Finally, look at the encircled point marked by an arrow. It so happens that the value in the digitizer at the moment of sampling was a false one. When it reaches the computer however the difference from its predecessor looks reasonable and so it is accepted. We now have a false shoal sounding on the chart, with the consequences described earlier. Had the computer been able to compare the false echo with the sounding immediately preceding it, the program would almost certainly have discarded it.

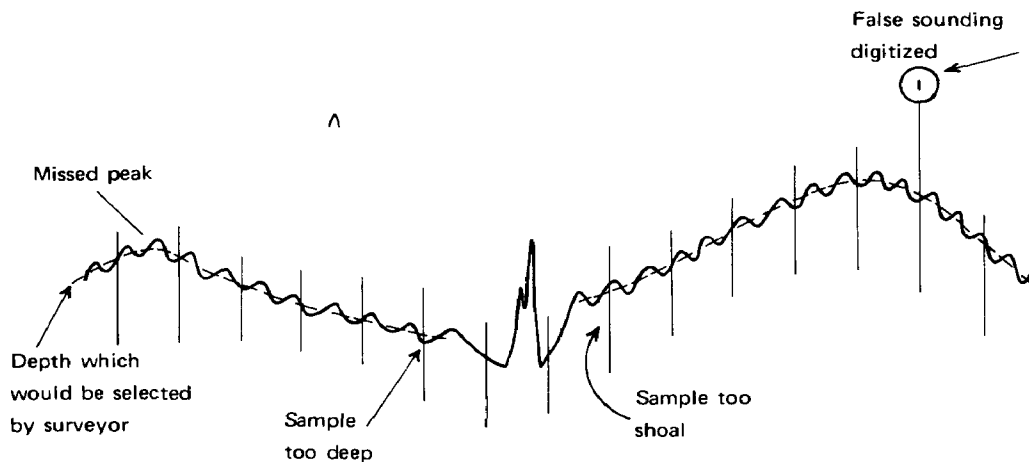

FIG. 6. — Effect of sampling on depth selection.

If we want a fully automated system, one in which the surveyor does not feel that he ought to check every sounding on the chart, then I believe that the computer must be given every sounding to look at.

ADVANTAGES OF A SHIPBOARD COMPUTER

I mentioned earlier that there is a broad choice between using the computer ashore or on board ship, and that the great majority of work to date has used a shore computer. The reasons for this are obvious — the early computers were large, sensitive to their environment and expensive — each factor alone a valid reason for not putting one into a survey boat. Furthermore the kind of organization that had a need for automation — like the major Port Authorities — normally had access to a shore computer and the Survey Department might even be encouraged to use it in order to spread the considerable overheads of such an installation.

None of these reasons however is any longer valid. The combination of solid state technology, mass production, and fierce competition has resulted in a dramatic reduction in both size and cost of small computers, to the point where the computer is today both smaller and cheaper than the great majority of data loggers. As far as reliability is concerned, today's computer is probably an order of magnitude more reliable than its peripheral units, the teletype, the tape recorder, the paper tape punch, which are necessarily electro-mechanical, and which, I might add, are required for a data logging system also.

There is then no longer a good reason for not placing the computer on board. What, you might ask, are the reasons why you should?

I can suggest a number, which will apply with varying force to different organizations. The first overwhelming one is economy, as

compared with a shore computer. If you accept my thesis that the computer must look at every one of those 360 000 soundings, plus the associated position conversion from hyperbolic to $x-y$, then that represents a considerable load for any computer. Let me give you some examples. Last year the Detroit district of the U.S. Army Corps of Engineers bought one of our data logging systems and have been recording five soundings a second on magnetic tape. They have found that it takes at least four hours on the computer for every eight hours in the field.

Our own experience with the Surveymarine hovercraft, logging fewer soundings per second, but using a paper tape system, showed that we needed eight hours on the computer for eight in the field. After the Surveymarine trials in fact, our draughtsman had his chart drawn in four days and then had to wait another ten days for the computer drawn version.

In a naval vessel the task of processing the data is necessarily performed by the same personnel — the surveying officers and recorders — who are responsible for collecting it. Consequently if they are relieved of having to process the data, more time is available for collecting data.

I think most people would agree that the naval surveyors currently have to work unreasonable hours and that they should share in the benefits of automation. Let us again be conservative in our estimates and say that automation will result in a saving of two hours of the surveyors' time each day, and that, of that time, one hour will be given to the surveyors and one hour devoted to extra field work. That single hour is equivalent to an increase of production of over 10 %. With the cost of running a survey vessel lying between two and three thousand pounds a day, again the cost of automation is soon recovered.

Another advantage is freedom of action, since the vessel is no longer tied by the logistic requirement to return each day's tape to the data centre for processing. This is of over-riding importance to a naval vessel of course, but applies to a lesser degree also to vessels working in the extensive areas surveyed by say the Port of London Authority or the Rijkswaterstaat. Associated with that advantage is speed of producing results, since they will always be available before the next day's work is started, so that the surveyor may conduct his interlining and examinations while he is still in the area.

An onboard computer can continuously convert the hyperbolic position readings into $x-y$ — in Autocarta it is doing this once per second — and it is a trivial additional task to require it to provide track guidance to the helmsman, by means of a Left/Right Indicator. This allows straight lines to be run in any direction, but, perhaps more important, the lines are parallel. Without a computer the vessel must derive its guidance from the position lines of the fixing system. With a hyperbolic lattice these lines converge and the inner ends of the line will necessarily be over-surveyed if the correct spacing is not to be exceeded at the other end. The U.S. Coast and Geodetic Survey, as it was called then, surveyed a 100 square mile area with a data logging system in 1968 and repeated the same area with an onboard computer system in 1969. They proved a 30 % increase in output from this cause alone [2].

Finally there is the considerable psychological advantage of keeping the responsibility where it belongs, with the surveyor. He is responsible for the whole task right through to the final chart. This is much more satisfactory for him and avoids the somewhat unrewarding conflicts between the field men and the shore office that inevitably arise, each blaming the other for the shortcomings of the system.

THE AUTOCARTA APPROACH

I think that most of what I have said so far could be applied to any onboard computer system. I will now tell you something about Autocarta in particular. I think that there are three areas that the surveyor will be particularly concerned about — how accurate it is, how can he check what is coming out, and how reliable will it be.

Let us then take accuracy, and divide it into two sections, position and depth. Taking position first, all our calculations are done on the survey grid. Once a second we compute our easting and northing from the hyperbolic or two range values, and then re-compute the scale corrections which will be used for the next calculation. We have checked our algorithm against a spheroidal solution, in which we calculate latitude and longitude and go from there to grid. The check computations were done

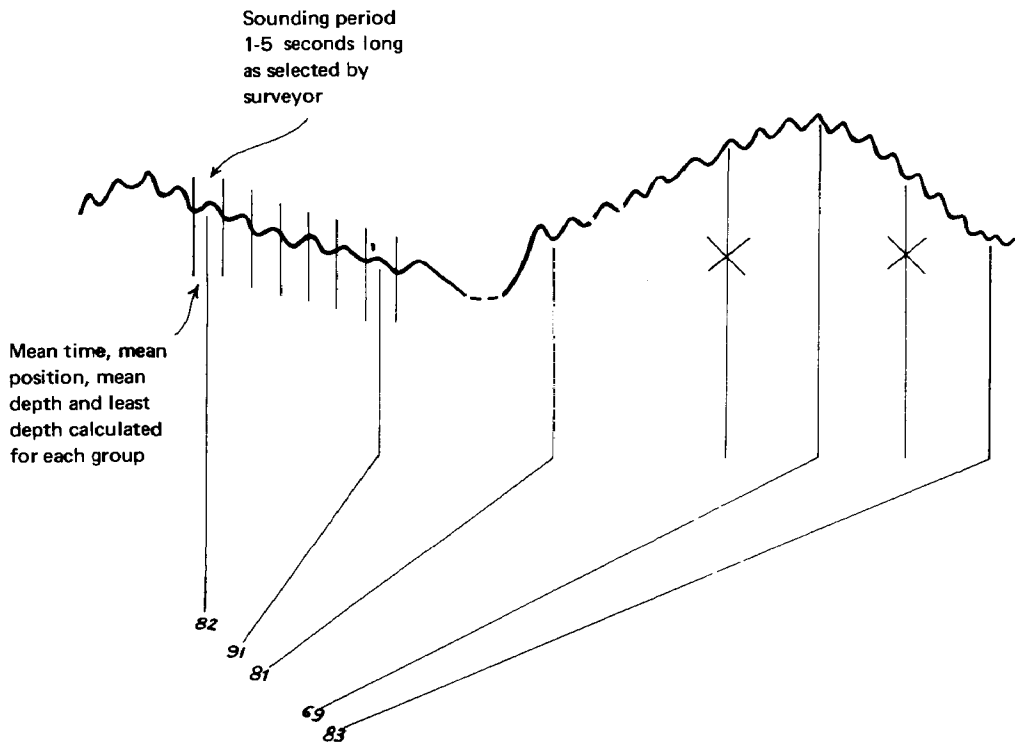

FIG. 7. — Autocarta depth selection.

on a Univac 1108, using 72 bits of precision, and we agreed within .2 of a metre for some twenty points. The test chain had 50-60 mile baselines and was at a distance from the Central Meridian.

The depth problem is a little more complex. On a typical echo trace, (figure 7) let us assume that we have already eliminated the false echoes. Our approach is to take a group of soundings and determine a mean time, a mean position, a mean depth, and a least depth for that group. The duration of the group may be from one to five seconds as selected by the surveyor, depending on the scale, the speed of the vessel, the sounding rate of the echo sounder, and the sea conditions. Let us assume that the first group was a selected sounding. We then go on, looking at the following groups, and each time we compute our distance, on the chart scale, from the previous selected sounding. As soon as this distance becomes large enough to write in another sounding, that sounding is selected. However the program is always on the look out for shoals. When one occurs, the preceding and succeeding selected soundings are dropped — to avoid overwriting — the shoal is recorded in its correct place, and the process continues. Thus you will normally see a wider gap than usual on one side of a shoal sounding, but this is inevitable if the shoal is to be shown in the correct place without being over-written. Apart from shoals, where the least depth is used, the mean depth is always the one selected for insertion.

At this stage we are not writing anything, each one of those selected soundings is merely being recorded on tape, either paper or magnetic. Then at the end of the day we put a different program in the computer, enter the tide readings, and run the intermediate tape back through. The plotter will then draw each reduced sounding in its correct place.

We must never allow the situation to develop where the man in the field accepts what comes out of the computer with blind faith. A computer assisted survey is no less prone to error than any other, and the surveyor must have the means to check everything that is done. The surveyor himself is not infallible and he might inadvertently erase the magnetic tape containing his day's work; if that day's work is not to be lost he must have the means to replot by hand from the raw data. Similarly when the survey is being examined in the Hydrographic Office the requirement occasionally arises to replot some part of the work. For all these reasons we believe that hard copy raw data records are imperative.

The records we provide are pretty much what the surveyor is used to — a fix on the echo trace once a minute, or multiple of a minute, and a printout of Time, Pattern I, Pattern II, Easting, Northing and depth at each fix. The only job for the watchkeeper on line is to number the fixes on the plot and the echo trace.

If at any time in the future the surveyor distrusts a sounding, he has only to lay his sounding sheet over the track plot to locate the nearest fix number and he may then go straight to the appropriate place on the echo trace and on the fix listing.

Surveyors today are dependent on electronics, and I expect we have all experienced that feeling when there is a beautiful calm day, you can

see for miles, and, let us say, the Hi-Fix is out of lock. Then we curse all electronics and wish we could go back to sextants — but we can't because we are no longer organized for it. We shall in time become equally dependent on automated systems and there is no concealing the fact that the complexities of such a system are of a different order from the electronics that we are used to.

We took this factor into account when we were designing the system and we accepted the premise that the continued functioning of the vessel is of paramount importance. We also made the assumption that the peripheral units, being in general electro-mechanical, are of a lower order of reliability than the computer itself, which is entirely solid state. In order to avoid a malfunction in any peripheral unit from inhibiting the whole system, we have provided what may be called functional redundancy, whereby the function of every peripheral is duplicated, albeit in a slower or less convenient way. Thus if the Left/Right Indicator fails, we may obtain steering guidance from the plotter; the intermediate tape may be generated on either paper or magnetic tape; programs are provided on both paper and magnetic tape; data and instructions may be entered through both the keyboard/printer and the keyboard/display. Our aim is that work shall not be stopped by a failure of any peripheral.

This still leaves the computer, which of course is central to the whole system. Our policy here is to include a complete spare computer as the principal component of the shipboard spares outfit. This approach has the double advantage that the surveyor can keep the system running with a minimum of technical knowledge while the technician has a spare of every card readily available when he comes to trace the source of the problem.

AUTOCARTA B AND AUTOCARTA P

So far we have been discussing the Autocarta X, which is designed with the major survey vessels of a Government Hydrographic agency in mind. These vessels normally carry three or four sounding boats and it is desirable to extend the advantages of automation to these soundboats also. They do not require as sophisticated a system as the mother ship, but they do operate in a considerably more hostile environment, so for them we propose what we have called Autocarta B — for boat (see figure 8).

This system is designed to be used in conjunction with an Autocarta X system in the mother ship, which will do the final editing and plotting. The system is half the size of the larger system — occupying one 19" rack — and contains only the more robust of the peripheral units. No attempt is made to achieve functional redundancy since the running cost of the vessel does not justify it.

One great advantage of having a computer on board each boat is that the positioning system may freely be used in the hyperbolic mode. It is difficult to draw large scale hyperbolic lattice charts without access to a

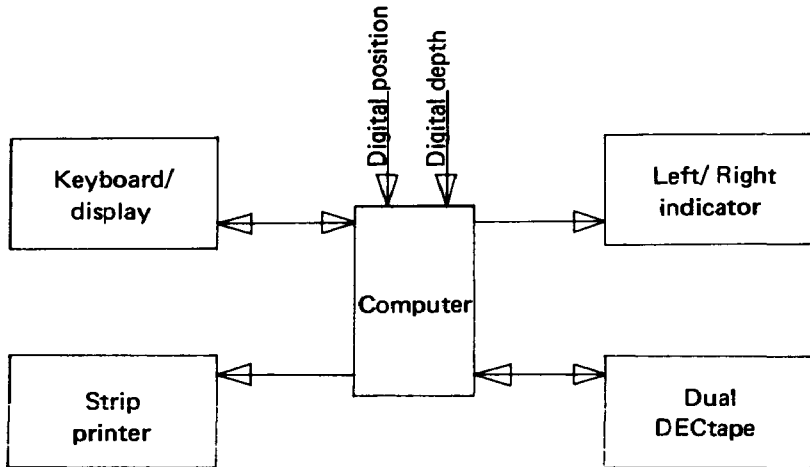

FIG. 8. — Autocarta B - Functional diagram.

computer, and a survey vessel working overseas can rarely obtain the coordinates of the transmitting station sites in time for these charts to be prepared at the home office. Consequently the ship normally deploys its positioning system in Two Range mode — where the charts can be prepared on board — and the boats either have to use sextant fixing, requiring a lot of time to be spent in providing shore control, or they sound in company with the ship — and reduce the speed of the ship to that of the slowest boat.

In the Autocarta B system the data is recorded on DECtape, a special form of magnetic tape which is rather wider than the usual magnetic tape, and data is recorded simultaneously on two parallel sets of data channels. When the tape is read, it is read off both sets of channels simultaneously, and should a bit have been dropped from one channel it will be picked up from the other. Thus the risk of loss of data is greatly reduced. In addition there are timing marks on the tape, so that the tape speed may vary by up to 30 % without causing problems.

For these reasons DECtape is used for both the Autocarta B and the Autocarta X systems. However DECtape has one great disadvantage — because of its unique format it is not compatible with the normal magnetic tape units found on the great majority of shore computers. This has made it necessary to introduce yet a third system, Autocarta P, for Port Authority, which is intended for vessels which return to the same port every night and which have access to a shore computer. This uses a normal IBM compatible tape as its primary recording medium, with paper tape capability as a back up. It is the same size installation as Autocarta X, except that it does not include a plotter (see figure 9).

The Autocarta P system is used on line in exactly the same manner as Autocarta X; the only difference is that at the end of the day the tape containing selected soundings is transferred to the Port Authority's shore computer. In this respect it is very similar to a logging system. The big difference however is that instead of giving the shore computer 360 000 soundings we are giving only the 500 to 5 000 that are actually going to appear on the chart. Instead of giving it a large amount of somewhat

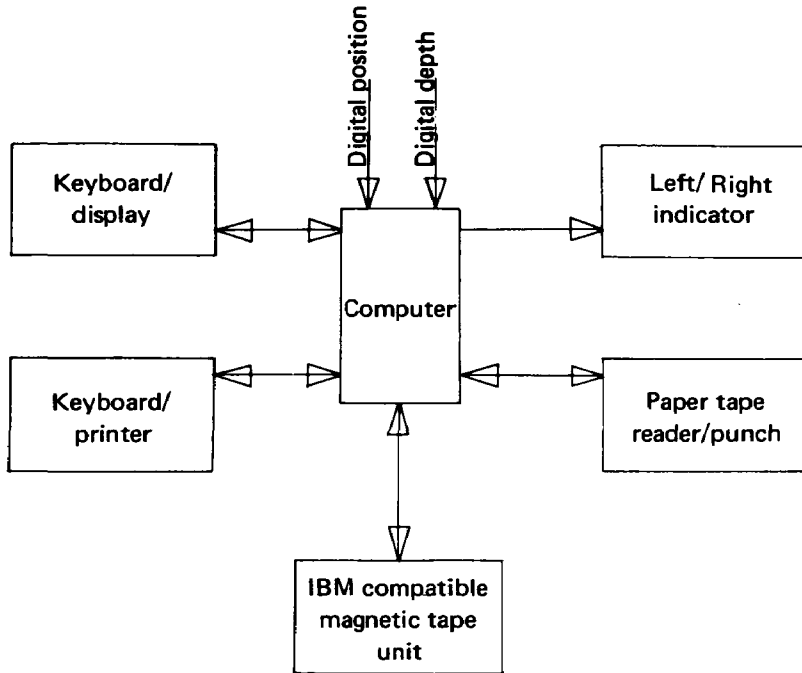

FIG. 9. — Autocarta P - Functional diagram.

complex mathematics to perform, in converting from hyperbolic to x - y , we are giving it soundings ready to plot, with only the tidal correction to apply. These then are the three standard systems, with firm specifications. In addition there are various expansion capabilities — flatbed plotters, coordinate digitizers, additional memory, which allow the use of the system to be greatly extended. A special proposal would normally have to be prepared for extended systems however since every user's requirements will differ.

RESULTS

I would like to draw your attention to some soundings we took in Torbay (see figure 10).

Looking at the figures themselves where despite a somewhat poor quality print, which has filled the centre of many of the small figures, you can still distinguish each individual digit. Those familiar with the normal computer drawn figure will be aware that the same basic shape is used for the 3, the 6, the 8 and the 9. This is fine for the computer since it is economical in core, but causes problems for the user when the plot is photocopied — and in particular photo-reduced — since the end result is frequently a collection of indistinguishable blobs.

The seabed in Torbay is very flat and the contours drawn are at an interval of one decimetre — about four inches. I think you will agree that it would be difficult to draw contours as straight and consistent as

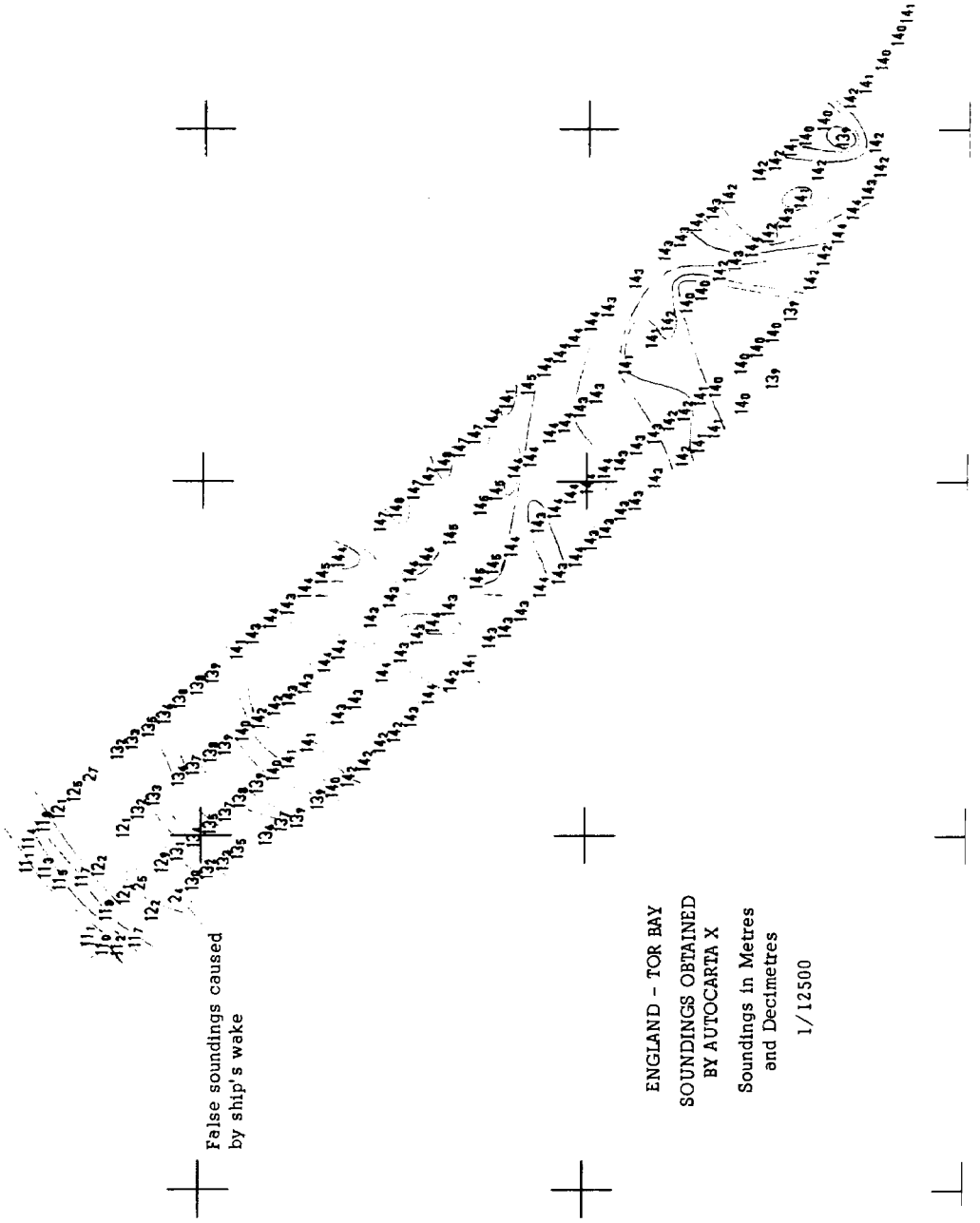

FIG. 10

these had we processed the data by hand. On the basis of these contours I am prepared to claim that the computer drawn chart can be more accurate than the conventional one.

The contours on the chart were all drawn by hand and in the present state of the art I believe that we should continue to do this. Erroneous soundings will still find their way on to the chart, and it is essential that we should force the surveyor to look at every sounding. The best way to do this is to make him draw the depth contours.

Finally, there are two suspicious looking 2 metre soundings in the northwest corner, in the middle of 12s and 13s. When we saw these we did what I suggested the surveyor should do; laid the sounding sheet over the track plot and identified the suspect soundings as coming from fix 55 and a little after fix 57 (figure 11). In each of these places you can see a distinct echo close to the surface which might have been caused by fish but which was more probably caused by the aeration of another ship's wake. The digitizer return shows that the digitizer in fact digitized those echoes in preference to the seabed — the Atlas digitizer uses logic rather than gating circuits and consequently accepted the false soundings after obtaining consecutive soundings separated by less than a metre.

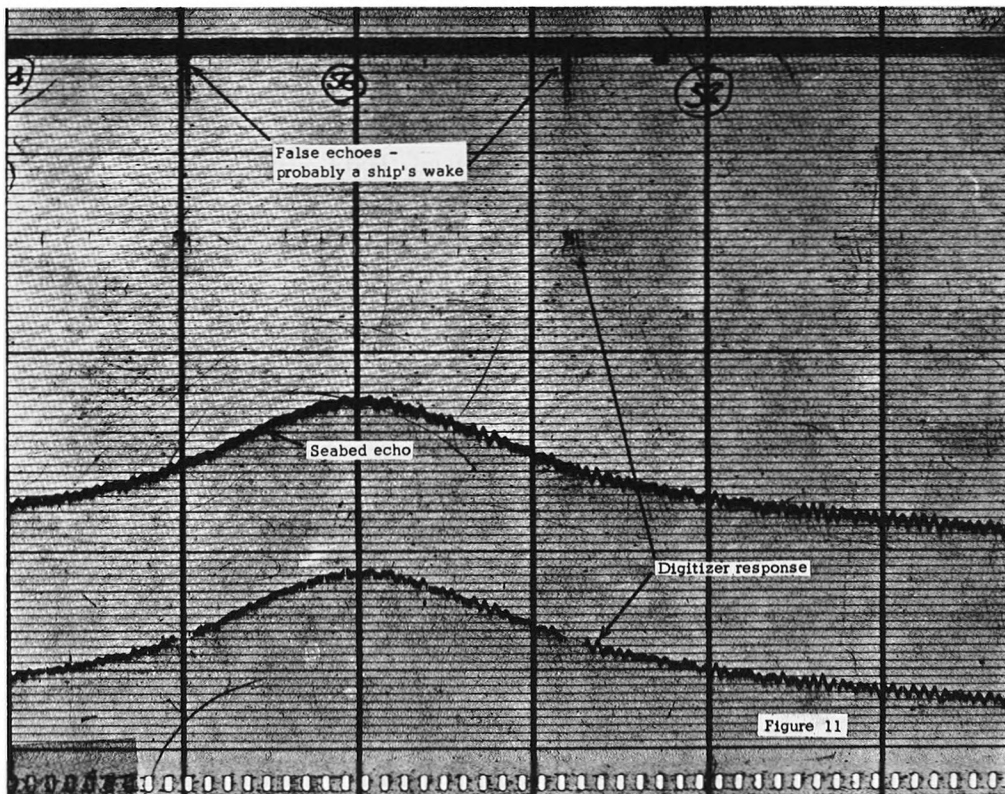

FIG. 11

It might well be asked why the computer program did not discard the erroneous soundings. The maximum allowable difference between consecutive soundings was in fact set at one metre, but after discarding

ten false soundings the gate was effectively set at ten metres, and by the eleventh or twelfth such sounding a false one would be accepted. Had the allowable difference been set at 2 or 3 decimetres all the false soundings would probably have been eliminated — but the surveyor would still have had to check the trace to explain the gap on the chart.

The moral, I believe, is that the surveyor is just as necessary as he has always been. He must inspect the echo trace for wrecks, draw the depth contours to interpret the soundings and use his judgment to determine where additional sounding lines are necessary. Above all he must check himself wherever he suspects that the machine has been led astray or misinformed. This however is interesting work requiring judgment and discrimination; work moreover that he will have time to do properly once the machine relieves him of the tedium of selecting and drawing soundings. There is hope that balance might be restored; the balance that was upset when the advent of electronic positioning systems allowed the collection of data to outstrip the facilities for processing the data.

REFERENCES

- [1] DICKSON, A.F. : Underkeel Clearance. *Journal of the Institute of Navigation*. London. Vol. 20, No. 4, Oct. 1967.
- [2] UPHAM, Cdr. Clinton D. : High Speed Data Acquisition for Large Scale Hydrographic Surveys. American Congress on Surveying and Mapping, Washington, D.C., March 1970.

(Manuscript submitted in English).