

MEASUREMENT OF WATER DEPTH BY THE ANALYTICAL PLOTTER

by S.E. MASRY

Department of Surveying Engineering,
University of New Brunswick, Canada

An update of a paper presented at the eleventh annual meeting of the Canadian
Hydrographic Conference, Ottawa 1972.

ABSTRACT

When an object submerged in water is photographed with a camera in the air, the image-forming rays undergo distinct refraction. The use of conventional photogrammetric plotters in measuring from such photographs can be complicated and inaccurate. The mathematical projection principle of the analytical plotter, on the other hand, allows for the effect of refraction to be accurately calculated during the measurements. With the use of such a plotter continuous and accurate measurement and plotting are, therefore, possible.

A method for treatment of refraction was developed and tested using the analytical plotter model AP/2C. The technique can be followed in measuring of hydrological models and mapping of shallow water areas where the bottom appears in the photographs.

INTRODUCTION

Since the use of photogrammetry in the field of hydrography is as yet limited, an outline of photogrammetric methods here may serve two purposes:

- (a) To draw the attention to the capabilities and limitations of photogrammetry applied to hydrography, and
- (b) To introduce the subject matter of this paper, which is rather a new development in photogrammetry.

Photogrammetry, as the word implies, is concerned with the determination of the dimensions of an object by measurements, using photographs of the object. So far, most of the measurements are carried out utilizing frame photography rather than strip, panoramic and other types of dynamic photography. We shall, therefore, deal here only with frame photography. The method of determination, and consequently the photogrammetric instruments used, can be divided into the following categories or combination of them:

- (1) Analytical methods: where the x - and y -coordinates of detail points are measured on more than one photograph of the object (fig. 1). Measurements are performed using a stereo- or mono-comparator. Employing the principle that the photograph is approximately a perspective projection of the object, the positions of the camera and the coordinates of object points can be determined analytically.

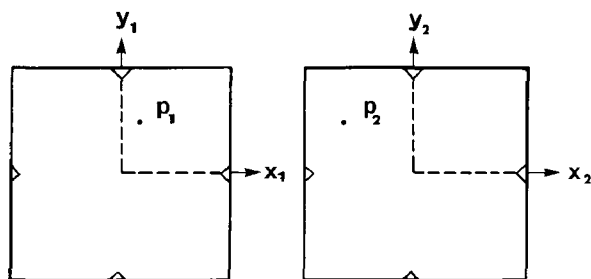

FIG. 1. The coordinates of corresponding image points are measured from which the object points are determined analytically.

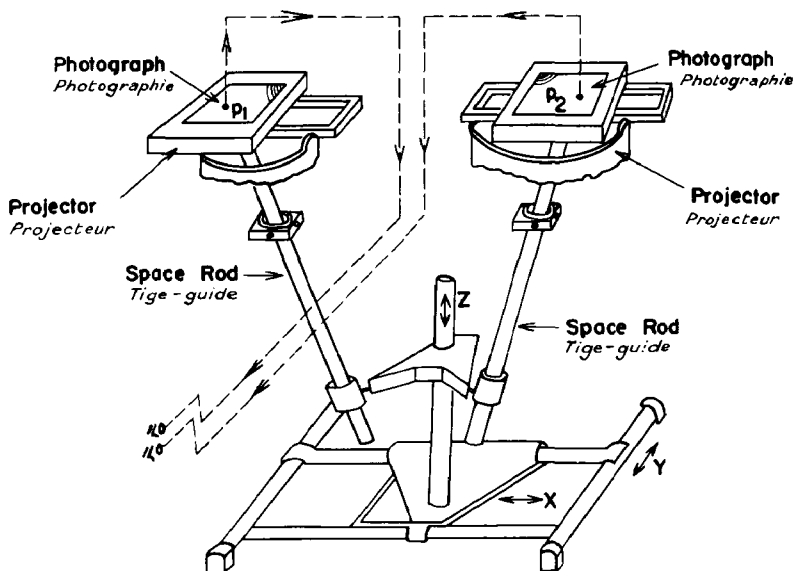

FIG. 2. — Scheme of an analogue stereo-plotting instrument. The projectors simulate the taking cameras and the space rods simulate the imaging rays.

- (2) Analogue methods: where two photographs of the object are placed in two projectors which simulate the taking cameras (fig. 2). The imaging rays are represented in the instrument by space rods (e.g. Wild A-10) or actual rays in projection-type instruments such as the Multiplex, Balplex, etc. The projectors are provided with rotational and translational movements which allow reconstruction of the taking camera positions, whereby the operator sees continuously a stereo-model of the object.

Each method possesses a number of advantages and disadvantages. Two of these are particularly relevant here:

- (1) Continuous Measurements: The analogue method is more suitable for continuous measurement as in the case of plotting detail and contours of the object. The amount of observations and calculations make the analytical method suitable for the determination of a number of object points rather than for plotting.
- (2) Flexibility: The analytical method is more flexible since the camera parameters and the mathematical model used can be varied at will. The flexibility of the analogue methods, on the other hand, is limited by the physical characteristics of the instrument. This point is of particular relevance to hydrographic applications of photogrammetry because, as we shall see below, the presence of distinct refraction of the imaging rays or lens distortion cannot be taken care of easily with analogue instruments.

THE ANALYTICAL PLOTTER

An instrument which combines the advantages of both the analogue and the analytical methods is the analytical plotter. The instrument was conceived by HELAVA at the National Research Council of Canada in 1957. The instrument (fig. 3) utilizes a mathematical projection principle where the restitution of a stereo-pair of photographs is determined and maintained by a control computer in real-time.

The instrument model at the University of New Brunswick consists of the following main components:

- (a) The viewer: where the stereo-pair of photographs is placed on two stage carriers driven by servo motors under control of the computer. The photographs are observed by the operator through an optical system.
- (b) The plotting table: on which plotting from the stereomodel can be carried out. The movement of the plotting head is also controlled by the computer, simultaneously with the viewer, in real-time.
- (c) Teletype unit for input/output operations.
- (d) Control computer of the system: which is a high speed digital computer. It controls the viewer and table in real-time. It also performs the calculations of the orientations of the photographs using data entered through the viewer.



FIG. 3. — The Analytical Plotter Model AP/2C at the University of New Brunswick. From Left to Right — control computer of the system (interfaced with an IBM 360/50), teletype unit, viewer, and plotting table.

A general organization of the components is shown in fig. 4 and a general flow chart of the real-time program is given in fig. 5. For more information about the plotter the reader is referred to [1].

It may be worthwhile to emphasize here, however, why the instrument is most suitable for treatment of factors such as large refraction of the imaging rays. In contrast with the conventional analogue instruments, all parameters pertaining to the photography (such as camera attitude, principal distance, imaging rays, etc.) are represented digitally in the computer. These parameters are continuously used by the control program to calculate the positions of the two photographs in the viewer, so that the stereo-model is maintained. In these calculations, the effect of refraction and other factors can be included.

TWO MEDIA PHOTOGRAPHY

When the camera is in one medium, such as air, and the object is in another medium, such as water, the imaging rays endure distinct refraction. In measuring from a stereo-pair of this type, the effect of refraction should be taken into consideration.

Fig. 6 depicts the case where the object point P is in a medium different from that of the camera. S_1 and S_2 are the two camera stations. The two imaging rays from P to S_1 and S_2 are refracted at p_1 and p_2 which lie on the boundary surface between the two media.

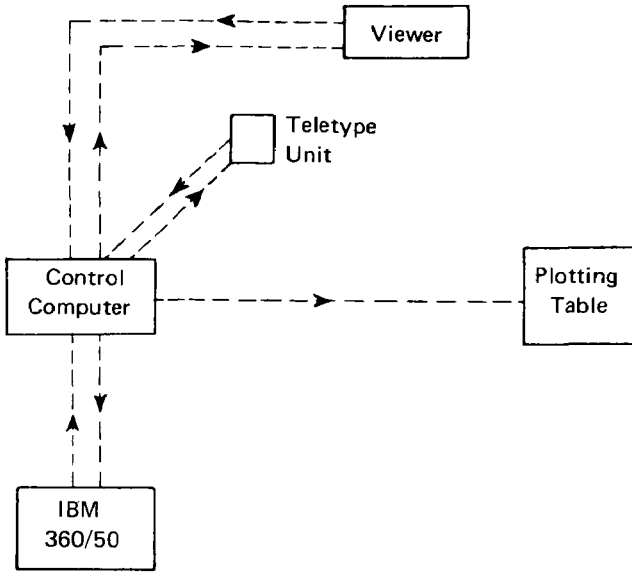

FIG. 4. — General arrangement of the analytical plotter. The control computer was interfaced with an IBM 360/50.

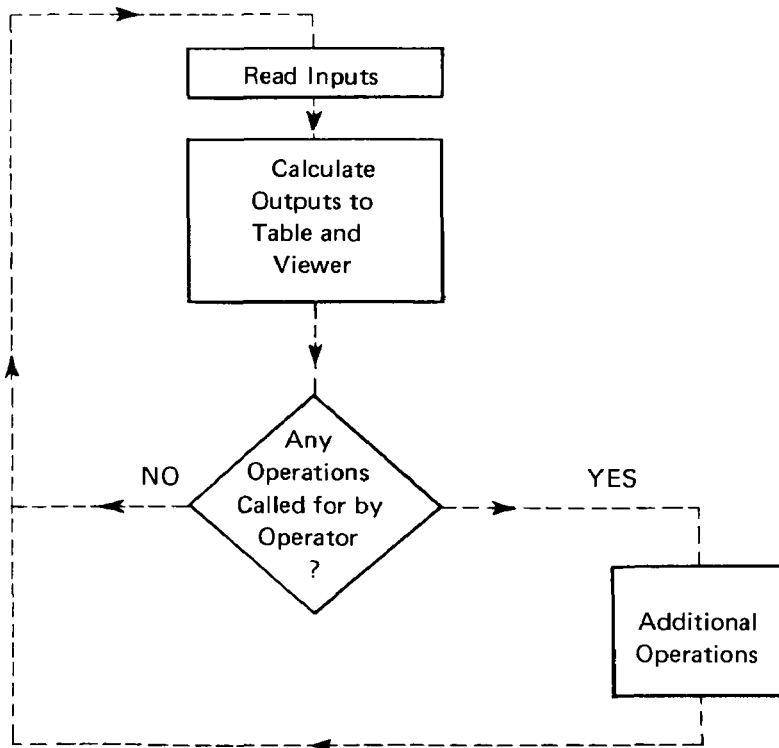

FIG. 5. -- Simplified flow chart of the real-time program of the plotter.

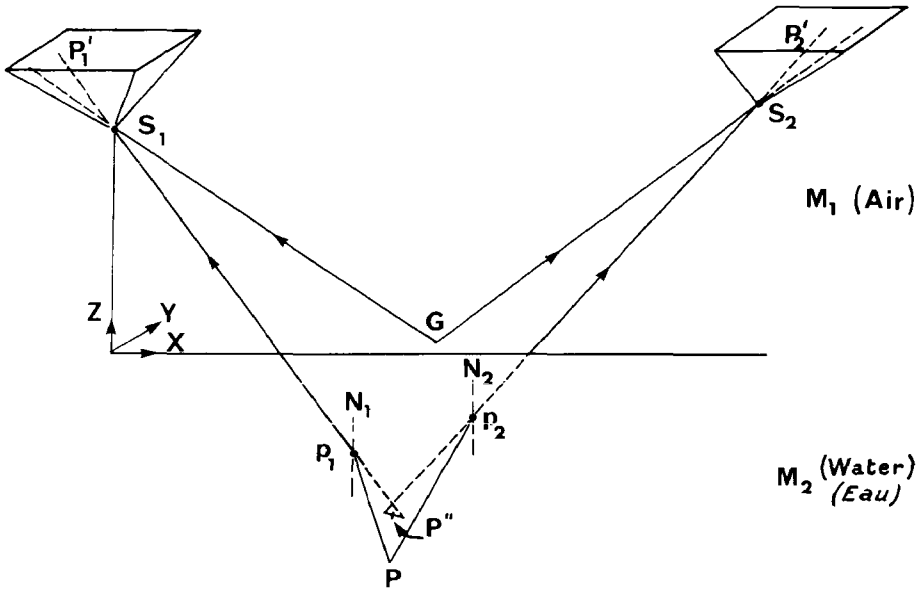

FIG. 6. — Geometry of two-media photography.

In an analogue instrument where the rays are represented by space rods, it is obviously not possible to bend the rods in a continuously changing form to represent the imaging rays. An approximate method of dealing with the problem is to assume that the space rods represent the parts p_1S_1 and p_2S_2 of the rays. Since these are generally non-coplanar, the stereomodel will appear to have what is termed as y-parallax; a situation which arises in the instrument when the restitution of the photographs is not perfect. In this case, the operator can remove the parallax at the point of measurement; and the height of a point P'' is measured. Correction

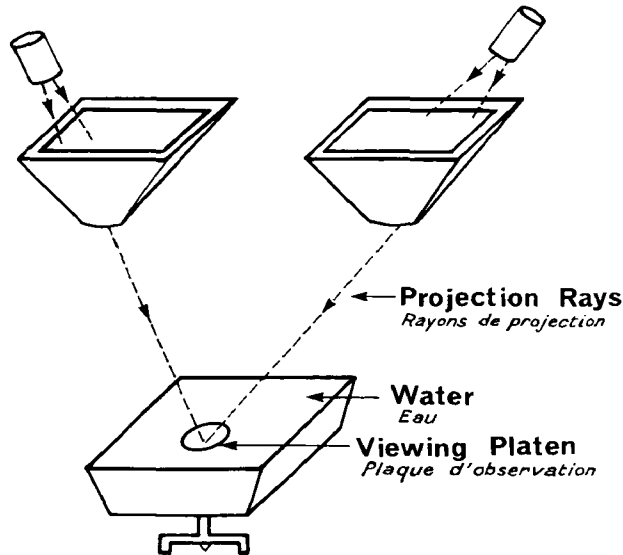

FIG. 7. — Water is used to reconstruct refraction in the case of double-projection instruments.

formulae have been developed to calculate the approximate height of point P from that of P'', [2] and [3]. (The horizontal position of P'' is not identical to that of P, [4]). The method is, therefore, approximate.

In double-projection instruments, reconstruction of the actual refraction may be achieved by using a layer of water (fig. 7) to refract the projection rays in the model area viewed by the operator [5]. Although theoretically correct, the method may not be very practicable.

TREATMENT OF THE PROBLEM USING THE ANALYTICAL PLOTTER

Knowing the position of the camera stations S_1 and S_2 (fig. 6), and the orientation of the two photographs, the positions of the corresponding image points p'_1 and p'_2 of the point P are calculated by the control computer of the plotter. The formulae used in the calculations are derived in [6]. The procedure can be summarized as follows:

- (1) Knowing the coordinates of P, the points p_1 and p_2 on the water surface are determined, so that the rays from P reach the camera stations S_1 and S_2 .
- (2) Having determined p_1 and p_2 , the image points are determined using the condition that the object point, the perspective centre of the camera, and the image point are on a straight line.
- (3) Having determined the position of the images p'_1 and p'_2 , the photo-carriages are driven by the computer so that these points are observed by the operator.
- (4) Most of these calculations are repeated continuously at a rate of about 30 times/second.

A point which is rather misleading is how the point P is known before knowing the refraction. It becomes much clearer as we consider the conventional case of a point G on the ground. The operator drives in the three directions X, Y and Z in the model space to the vicinity of G, and sees the measuring mark away from it. He then moves closer to the point. The process can be thought of as an iterative process. The same concept holds for points in the water.

In the program developed, the model coordinates system was chosen with the XY-plane coincident with the boundary surface. This allows the program to determine from the sign of the z-coordinate the medium in which the model point lies. Model points above the water, such as point G, are dealt with in the conventional manner, a feature which may be of value for coastal mapping.

TESTING OF THE METHOD

The program developed was tested and used in plotting from photography taken by a stereometric camera under laboratory conditions. The scale of the photographs was 1/65. Fig. 8 shows the stereo-pair of photo-

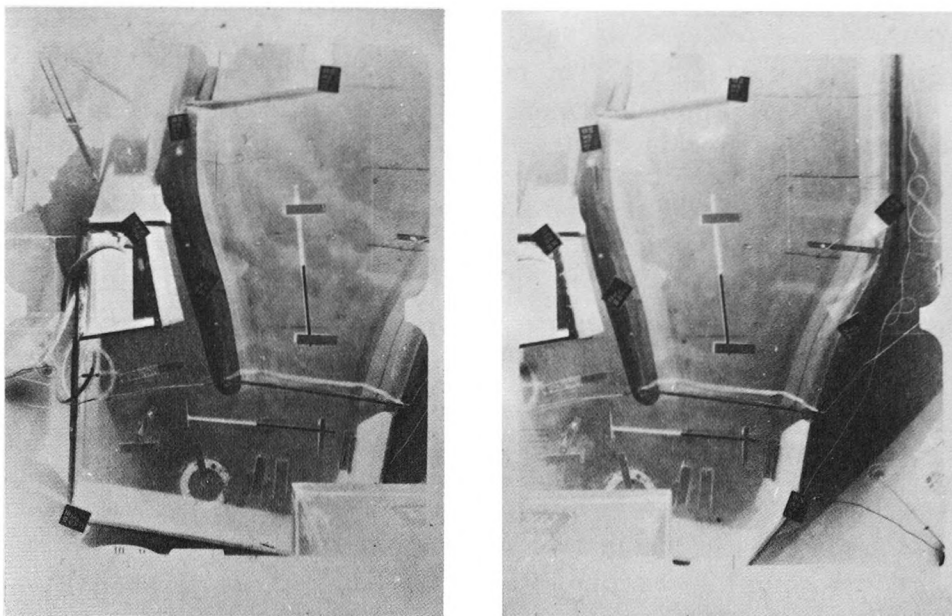

FIG. 8. — Stereo-pair of photographs used in the test performed on the analytical plotter.

graphs used and fig. 9 shows the map plotted. The mean standard error for height determination of points in the water was ± 2.5 millimetres, determined from 27 control points.

In this test, lens distortion and film shrinkage were neglected. Higher accuracy can, therefore, be expected if such corrections are taken into consideration. (An accuracy of ± 0.13 mm in height is reported in [7] where the camera parameters were determined from control points in the photography).

APPLICATION OF THE METHOD TO COASTAL MAPPING

Treatment of two-media photography taken under controlled laboratory conditions can be dealt with as explained above. Mapping of shallow waters, however, may not be as simple. A combination of factors may contribute to affect the accuracy of the measurements and/or the depth of penetration in the water. Factors affecting depth penetration of coastal photography are examined in [8]. It suffices to mention here the encouraging penetration depth of 90 feet reported in [2]. An attempt is made here to examine the factors which affect the accuracy of the measurements.

In coastal mapping, the surface of the water is not a plane. The refraction of the imaging rays depends, therefore, on the direction of the rays in relation to the waves (fig. 10). The error in height measurements due to that was estimated to be ± 4.6 feet in a depth of 60 feet [2]. The error is obviously a function of the deviation of the surface from a plane. Since this deviation is random, it cannot be easily corrected for.



FIG. 9. First map plotted using the analytical plotter.

Another factor which affects the accuracy is the orientation of photographs. The operations known as relative and absolute orientation of a pair of stereo-photographs require the observation of a number of points which appear on each photograph (fig. 11). The distribution of these points over the area of the model affects the accuracy of orientation and consequently the accuracy of the measurements. Since the water surface is continuously moving between consecutive exposures, no individual points on the surface can be selected for the purpose of orientation. The points selected are then confined to those on land and on the bottom (fig. 12). (The latter points may introduce some errors due to the effect of waves given above). Consequently, a weak orientation will result if the land coverage of the model is small.

Research is presently being carried out at the University of New Brunswick to utilize auxiliary data provided by Inertial Navigational

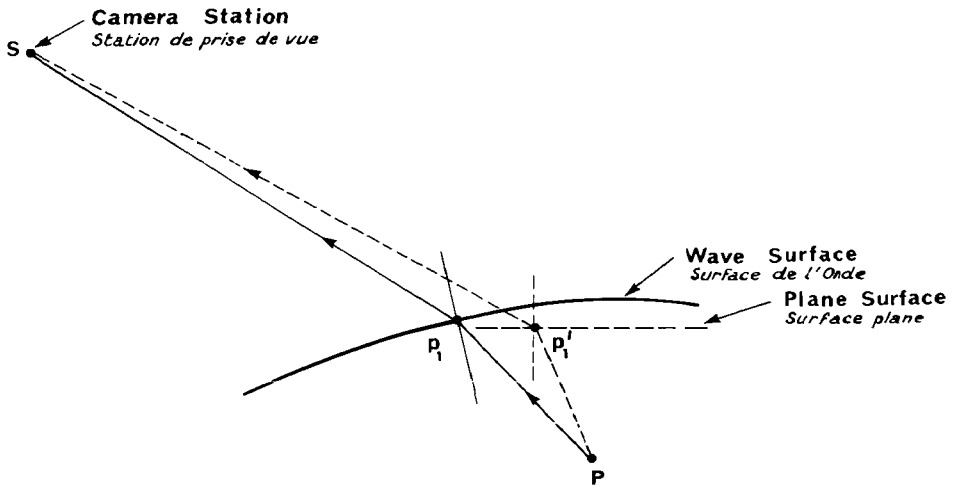

FIG. 10. — Refraction depends on direction of imaging rays in relation to water surface.

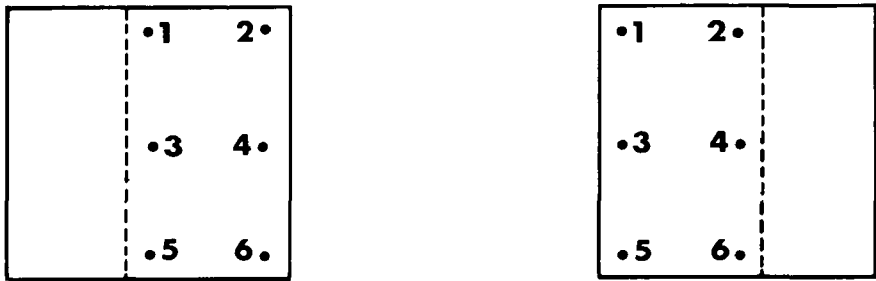

FIG. 11. — Usual distribution of points used in relative orientation.

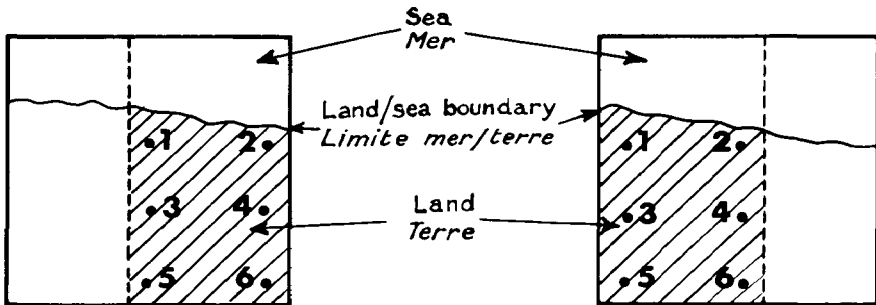

FIG. 12. — Orientation points are confined to a small area: weaker solution results.

Platforms in the orientation of the photographs. The results will be presented in further publications.

To test the method in the case of coastal waters, two stereo models were used. Each model had a land coverage of about 50% of the total overlap between the photographs. The photography was taken with a Wild RC8 camera using a Kodak 8442 colour film and HF3 filter. The flying height was 1 500 m and the scale of the photographs was approximately 1/10 000. The test area lies in the Strait of Georgia, British Columbia.

The depth measurements carried out consisted of spot heights. The measurements were compared with depth soundings and the results can be summarized as follows:

Water penetration extended over an area with a width up to 250 m from the water's edge and up to 7 m depth, depending mainly on sun reflection from the water surface and the contrast of the bottom. The accuracy of depth measurements compared to sounding measurements was:

	<i>Number of points</i>	<i>Accuracy</i>
<i>Model 1</i>	49	± 0.3 m
	9	± 0.61 m
	7	± 0.92 m
	1	± 1.23 m
<i>Model 2</i>	27	± 0.3 m

The root mean square error of all points in the two models tested is ± 0.45 m.

OTHER APPLICATIONS OF THE ANALYTICAL PLOTTER IN HYDROGRAPHY

The control program of the analytical plotter takes into consideration corrections due to lens distortion and film shrinkage. (The former distortion can be significant if a lens designed for air operations is used in under-water photography [7]). The plotter is, therefore, most suitable for applications where large distortions are encountered.

To study the distortion of sound waves reflected from the sea floor, measurement of the micro-roughness of the sea floor is necessary [9]. This is carried out by lowering a stereometric camera and taking stereo-pairs of photographs of the floor. Measurements of the underwater photographs are then carried out to determine the height at points of regular intervals in the stereo-model. A program was written for the plotter which allows scanning of the model and recording of the measurements at regular intervals [6].

CONCLUSIONS

A method for measurement of water depth using the analytical plotter was demonstrated under laboratory and field conditions. The method has good potential for mapping of coastal waters. Wide use of the method in

this application seems to be dependent on the development of instrumentation for the accurate determination of the orientation of the photographs. The plotter can be successfully used in other applications where refraction and large distortions are present.

ACKNOWLEDGEMENTS

The author wishes to thank Mr. N. ANDERSON of the Canadian Hydrographic Service, Pacific Region, for providing the aerial photographs used in the test and for several stimulating discussions, Dr. J. HÖHLE for providing the short-range photographs, Mrs. O. ADEKOYA for testing the aerial photographs, and Mr. D. WELLS for reading the manuscript and making useful suggestions.

REFERENCES

- [1] Proceedings of the Second International Photogrammetric Conference in Ottawa. *The Canadian Surveyor*, Vol. XVII, No. 2, 1963.
- [2] TEWINKEL, G.C. : Water Depths from Aerial Photographs, *Photogrammetric Engineering*, Vol. XXIX, No. 6, Nov. 1963, pp. 1037-1042.
- [3] GROENEVELD MEIJER, W.O.J. : Formulae for Conversion of Stereoscopically Observed Apparent Depth of Water to True Depth — Numerical Examples and Discussion. *Photogrammetric Engineering*, Vol. XXX, No. 6, Nov. 1964, pp. 1037-1045.
- [4] van WIJK, M.C. : Discussion paper — "Water Depths from Aerial Photographs" by G.C. Tewinkel. *Photogrammetric Engineering*, Vol. XXX, No. 5, July 1964, p. 647.
- [5] KREILING, V.W. : Einfache Auswertung von Zweimedien — Bildpaaren in Doppelprojektoren, *Bildmessung und Luftbildwesen*, 1970, pp. 345-347.
- [6] MASRY, S.E. and KONECNY, G. : New Programs for the Analytical Plotter. *Photogrammetric Engineering*, Vol. XXXV, No. 12, Dec. 1970, pp. 1269-1276.
- [7] HÖHLE, J. : Reconstruction of the Underwater Object. *Photogrammetric Engineering*, Vol. XXXVII, No. 9, Sept. 1971, pp. 948-954.
- [8] ANDERSON, N.M. : Colour and Infrared Photography as a Tool for Hydrographers. Proceedings of the Tenth Annual Canadian Hydrographic Conference, March 1971.
- [9] Deep Sea Photography. The Johns Hopkins Press, Baltimore 1967.