

## **A REVIEW OF THE BATHYMETRIC SWATH SURVEY SYSTEM**

by Edwin K. McCaffrey (\*)

---

Paper presented at the Second United Nations Regional Cartographic Conference for the Americas, Mexico City, 3-14 September 1979. Also at the 9th United Nations Regional Cartographic Conference for Asia and the Pacific, Wellington, New Zealand, February 1980.

### **SUMMARY**

The appearance in recent years of large ships with drafts approaching 30 metres has a serious impact on U.S. charting requirements. Previously, detailed harbor approach surveys were accomplished sufficient to define hazards within the 20-metre contour. The new, larger, commercial ships now require surveys to assure that all hazards and obstructions within 30 metres of the surface are located in charted channels, harbor approaches and ship fairways. A multi-beam bathymetric swath survey system (BS<sup>3</sup>) described here has the potential to meet these new survey needs.

The BS<sup>3</sup> employs a vertical fan-shaped array of 21 acoustic beams which forms a swath beneath the survey vessel with a width equal to 2.6 times the sounded depth. In addition to the usual vertical acoustic sounding, the oblique acoustic soundings are recorded and processed in real time to display contours of bottom features shoaler than the vertical depth. A computer is part of the BS<sup>3</sup>, utilizing a real time operating system to merge soundings, navigation inputs, real time telemetered tides and ship motions to output corrected soundings graphically and to a magnetic data tape. System development began in July 1976 and was delivered in September 1977. Preliminary field tests on a Government launch and aboard the NOAA survey ship *Davidson* are now being evaluated and the data analyzed. Indications are that the system will soon be certified and delivered to the NOAA survey fleet as an operational marine chart survey system.

(\*) Acting Associate Director, Office of Marine Technology, National Ocean Survey, NOS, NOAA, Rockville, Maryland 20852, U.S.A.

\*  
\*\*

In recent years very large crude carrying (VLCC) tankers have appeared. A typical ship of this class carries over 600 000 cubic metres of crude oil and weighs in excess of 500 000 DWT. These ships are over 400 metres long, 70 metres wide, and have a full-loaded draft of nearly 30 metres. Several kilometres are required to turn or stop a loaded ship of this size. It is apparent from this that detailed charting of depths in harbor approaches and VLCC sea lanes is now needed beyond the 30-metre contour. Existing conventional survey techniques are now adequate to accomplish this economically. The National Ocean Survey of the U.S. Department of Commerce has recently developed and successfully tested a multi-beam vertical sonar system with which it hopes to meet these new surveying needs. This system has been named the Bathymetric Swath Surveying System (BS<sup>3</sup>).

### BS<sup>3</sup> DESCRIPTION

The multi-beam system described here consists of a 21-beam vertical array of sonar projectors and receivers. The units are arranged in a suitable hull-mounted transducer assembly so that in operation they insonify a 150° fan-shaped swath normal to the survey vessel's forward motion. (See figure 1). The geometry of the system permits continuous acoustic bottom coverage of a strip equal in width to 2.6 times the sounded depth. This is equivalent to five or six times the bottom coverage of the usual single narrow beam acoustic sounder. Table 1 lists some of the technical characteristics of the BS<sup>3</sup>.

TABLE 1

#### Selected specifications of the Bathymetric Swath Survey System

Operating frequency.....	36 kHz
Sonar range .....	3 - 610 metres (vertical) 1200 metres (slant range)
Power output.....	180 watts
Power requirements.....	200 watts, 115 volts, 50-60 Hz
Ping rate.....	10 - 0.5 Hz depending upon depth
Pulse length .....	0.5, 1, 2 and 5 milliseconds
Number of formed beams ..	21
Depth accuracy (vertical beam) .....	±0.3 metre or 1/2 % of depth, whichever is less
Vertical range scale.....	25, 50, 100, 200, 400 and 800 metres (feet also available)
Horizontal range scale.....	50, 100, 200, 400, 800 and 1600 metres

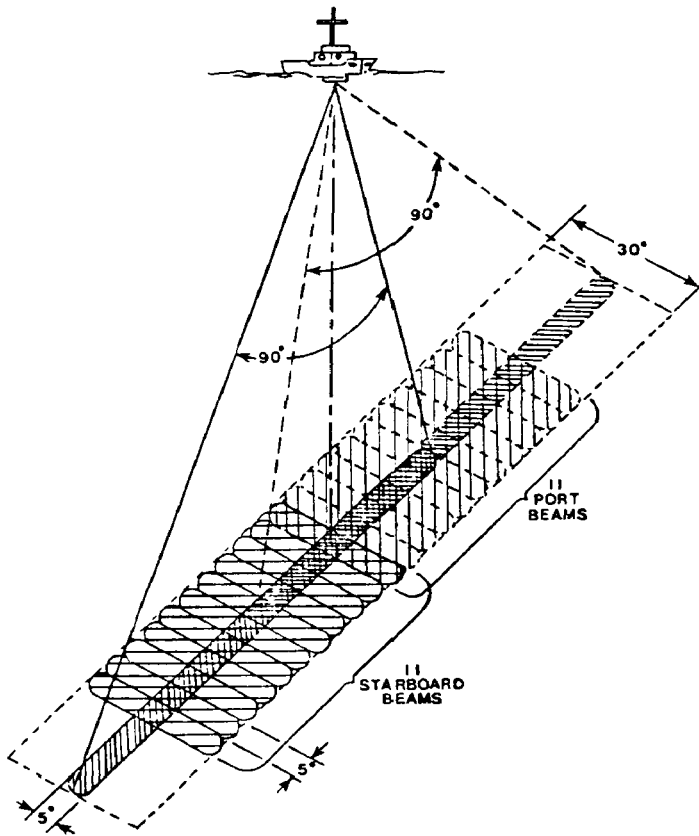
FIG. 1. - BS<sup>3</sup> geometry.

A cross fan-beam technique is used in the BS<sup>3</sup>. Two identical projector-hydrophone arrays, one port and one starboard, make up the 36 kHz transducer. Each projector produces a  $5^\circ \times 90^\circ$  fan-beam with the broad axis of the beam perpendicular to the ship's track or heading. The hydrophones receive the returned signals, which are delayed and summed to form 11 adjacent  $5^\circ \times 30^\circ$  listening cones whose major axis lies perpendicular to that of the projector fan-beams. The receiving fan-beams intersect the projected fan-beams in 11 adjacent 5-degree squares along the insonified bottom area. On a flat bottom, in 30 metres of water, a 5-degree square is equivalent to a coverage of  $2.6 \times 2.6$  metres for the vertical beam and  $2.6 \times 5.3$  metres for the outermost beam. The system time-shares the port and starboard arrays, alternately making 11 simultaneous slant-range measurements. A one-beam overlap of the two arrays produces a 21-beam system giving a cross-track coverage of approximately 2.6 times depth along a  $5^\circ \times 105^\circ$  strip perpendicular to the ship's track. Figure 1 illustrates the geometry of this technique.

The swath survey system is designed to be a real time tool for the chart surveyor. All data are recorded in real time on magnetic tape; a powerful mini-computer is incorporated into the system to merge and process incoming data into real time graphics necessary to complete the survey. These graphics are

output on two plotters. The slower line plotter depicts track plots in X-Y coordinates, at a selected scale, showing the survey vessel's track and the corresponding left and right limits of the total acoustic swath covered. Simultaneously, on the faster electrostatic plotter a real time sounding plot displays corrected vertical soundings plus contoured relief of those features detected by the other 21 beams which are shoaler than the vertical soundings.

Other peripheral sensor inputs, necessary to assure that the system operates in real time, include: interfaces with an appropriate radio-navigation system, with an onboard heave-roll-pitch sensor, and with a shore-based radio telemetered tide measuring system. In the absence of active telemetering tide stations, provision is made in the system to accept tabular values of predicted tides for the survey area. The operator can be interfaced with the system, making it possible to conduct various diagnostic inquiries and to input various commands such as scale changes, heimsman orders and sea-water sound velocity values to correct acoustic soundings.

Support of all these ongoing activities requires a real time software package to manage the data acquisition and create the necessary graphical displays and control orders to the various sensors.

Data management, processing and display is accomplished by the PDP 11/34, a 16-bit computer produced by Digital Equipment Corporation. This basic unit, operating in conjunction with the DEC RT-11 real time operating system, manages the software and data processing stored in the computer's 64K words of memory. An additional 512K bytes can be stored by an attached dual "floppy disk" drive. The survey data from all sensor systems are recorded on nine-track standard magnetic tapes at a rate of 800 BPI. A smaller complementary 4-track tape cartridge system logs operator inputs and summary survey information.

The computer and data display are interfaced with the data acquisition sensors using the CAMAC standard. The U.S. National Bureau of Standards and the Institute of Electronics and Electrical Engineers (IEEE) have defined the interface standards and data protocols for the CAMAC dataway bus and interfacing modules. Use of CAMAC permits interfacing with a variety of sensors, ranging from 24 bit, parallel I/O up to 9600 baud, serial I/O, digital or analog. The CAMAC modular design enables the computer to address selected sensors as required and as if they were already in computer memory.

Consideration of the 21 sonar beams formed (see figure 1) shows the need to compensate for the effects of vessel motion on acoustic soundings. It is apparent that the two projected signals are most affected by vessel pitch; whereas roll is the major contributor to depth errors in the 21 received beams. Additionally, the ship's vertical motion (heave) during survey operations may introduce an error approaching  $\pm 2$  metres into all 21 recorded soundings. To solve this problem, a heave-roll-pitch sensor (HRP) is an important part of the BS<sup>3</sup>. The HRP unit is placed near the survey ship's centre of motion. It measures accelerations and angular motions in the X, Y and Z directions utilizing linear accelerometers and a long (120 second) period pendulum. The sensor output is periodically sampled and integrated by an attached microprocessor to produce digital HRP information for the BS<sup>3</sup> computer. The data rate for HRP is equivalent to the sounding interval; that is, it produces a real time estimate of the heave, roll

and pitch at the time of each sounding. The sampling and integration rate produces HRP data points which lag the real time values by approximately 0.5 seconds. This approximated real time value produces an angular error of  $\pm 0.2^\circ$  or a heave error of  $\pm 6\%$  of the true heave value. This approximation is suitable for determining the initial real time sounding corrector and may be further reduced by later processing and merging of the tape recorded data.

As presently configured, the BS<sup>3</sup> is designed for interfacing with the usual short range or medium range radio positioning systems in use today. It has been successfully interfaced with range-range line of sight electronic systems such as the Trisponder or Mini-Ranger (9.3-9.5 GHz frequency) and the medium range hyperbolic Raydist system (1.6-3.3 MHz). The operational software contains navigational routines to provide the following real time position and navigating function: compute vessel's position in real time once per second using as input the digitized range-range or hyperbolic radio navigation data inputs. The coordinate system for vessel position computation is a metric X-Y, north-oriented system with the origin at the extreme southwest limit of the survey to assure all X-Y's are positive. This computation includes the position of the vertical acoustic sounding plus the corresponding X-Y coordinates of the outermost usable bottom returns from both port and starboard. Computations resolve ship speed, position, gyro compass heading, HRP data and sonar slant range soundings. Computation accuracies are  $\pm 0.1$  metres. The output of this routine is displayed on the slower pen plotter as the vessel position track and corresponding limits of surveyed track. The capability also exists in software to navigate the ship along predetermined survey tracks. The offset of the ship's position from the required line is computed and left or right steering commands are transmitted to a visual display unit mounted in front of the helmsman.

The survey system is configured to provide continuously zoned tide correctors at the sounding position based on inputs of real time (telemetered) or predicted tidal heights from up to three tide station locations adjacent to the survey area. Real time software provides these tidal corrections to a computational accuracy of 3 cm. Continuous tidal corrections are determined by computing a weighted average of the several tidal heights based on the vessel's distance from the tidal reference points.

Manual data inputs are provided for transducer draft corrections, transducer offset from center of motion, and sea water sound velocity values for up to 6 layers from the surface to the 610-metre operating depth. Sound velocity input must be known to within 2 m/s of the correct value. This value can be determined by traditional methods on a daily basis and the values entered into BS<sup>3</sup>. Velocity variations can be monitored using expendable probes to measure sea water temperature, density, or even sound velocity as a function of depth. Appropriate software routines in the BS<sup>3</sup> computer utilize this sound velocity input to provide corrections to the acoustic soundings. Accurate knowledge of sound velocity variation is more critical for multi-beam acoustic arrays due to the effect of ray-bending on acoustic slant ranges.

The computer subsystem and associated software suite are the heart of the system, required to accomplish all the foregoing operations. During actual survey operations, it is dedicated full time to executing programs and managing the data

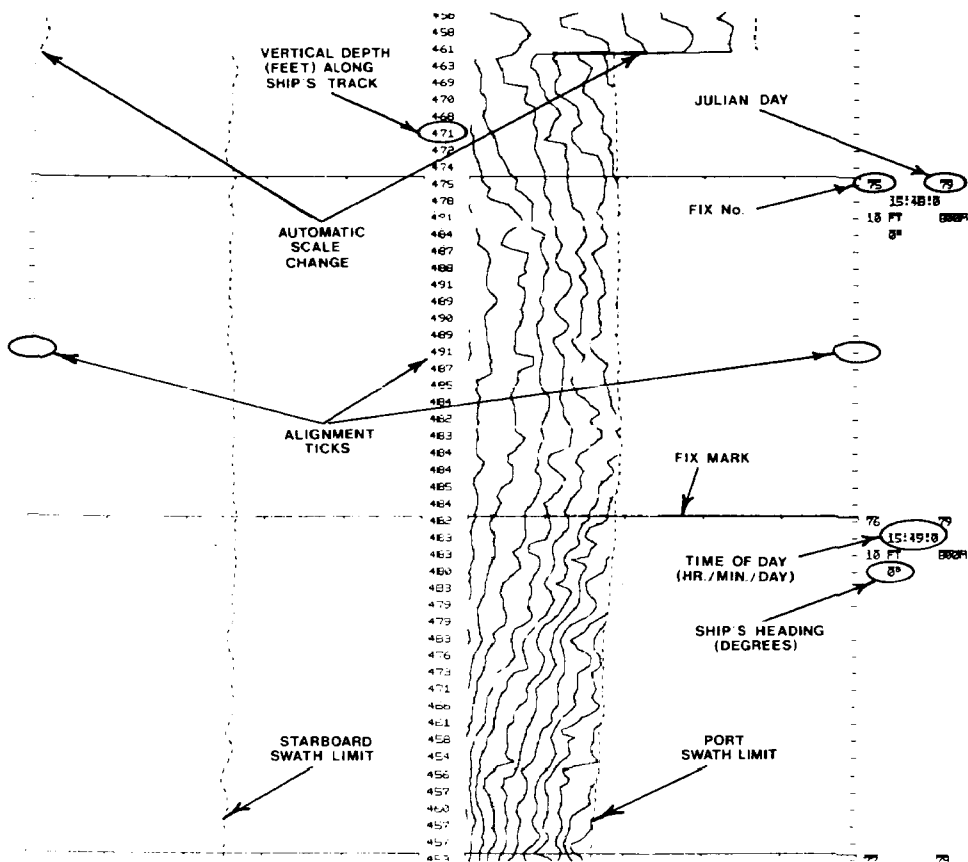

FIG. 2. - Actual hydro chart. Shoaling contour recording.

flow required to support real time operations. When survey operations are not being conducted, the computer system is available to perform reduction and processing of survey data acquired earlier and to perform auxiliary tasks needed to support survey operations.

Procurement of this system was begun in late 1976 with the General Instrument Corporation of Harris Laboratories, Westwood, Massachusetts, as the principal contractor supplying the hardware components of the sonar system and associated processor. Software development, to support the real time output of the system and to supply the peripheral sensors and equipment was a joint Government-contractor effort. The integrated hardware system, exclusive of tide measuring, HRP and navigation peripherals, was delivered in September 1977. Acceptance tests were begun at the time and continued through December 1977 with the system installed on an 18-metre Government survey launch, the *Laidly*, based at Norfolk, Virginia. These sea tests demonstrated the feasibility of real time output from a swath survey system. Interfacing of the telemetered tide measuring system and various short and medium range radio navigation systems with the BS<sup>3</sup> processor was also demonstrated at this time. Soundings to more than 1100 metres, nearly twice the design goal of BS<sup>3</sup>, with dramatic graphic

contour changes, were obtained for the submarine features of the Norfolk Canyon in the Atlantic Ocean east of Chesapeake Bay, Virginia.

As is typical in development projects of this type, many software problems were located and corrected. For future expansion of the system, an additional 32K bytes were added to the existing computer memory – a 100 percent expansion. In addition, experience acquired in this initial test program showed that the operating routines and memory management resident in the computer (DEC PDP 11/34) were inefficient, requiring extensive disk program overlay techniques. To alleviate this, it was decided to use the most recent version of the DEC real time operating system, the RT-11, version III. Adoption of the system required considerable conversion of existing programs which had been written to operate with the version II system. This program conversion was done as a contract extension by the General Instrument Corporation with consultant support by representatives of the computer manufacturer and was successfully completed by the end of April 1978.

In the early months of 1978, the prototype BS<sup>3</sup> was removed from *Laidly* and transported to Seattle, Washington, for permanent installation on the NOAA survey ship *Davidson* (57 metres LOA, 950 tons). This installation, including permanent hull mounting of the transducer assembly, was completed by February 1978. In the ensuing months of March through May, extensive operational field trials of BS<sup>3</sup> were conducted by *Davidson* and the ship's operational personnel in Puget Sound, Washington. Statistical repeat trials were run in the same area in November-December 1978. The heave-roll-pitch system was successfully integrated into the real time system and comparison surveys conducted using both the BS<sup>3</sup> and a conventional single beam acoustic sounding system in a pre-defined survey test area.

At the successful completion of the November 1978 Puget Sound test program, the BS<sup>3</sup> was used operationally in February 1979 off the northern California coast. This was a geophysical exploration of the underwater extension of the San Andreas Fault and excellent detailed contour records of this feature were obtained. However, later that summer, operations in the approaches to Prince William Sound, Alaska, saw an unacceptable incidence of "stray soundings" and unexplained shoal soundings appearing in known flat bottom areas. Operational use of BS<sup>3</sup> was discontinued and detailed analysis of this phenomenon began. Preliminary estimates suggested these spurious soundings were the result of sonar echo reverberation in the sonar dome. This hypothesis was tested and verified by a series of tests with *Davidson* in October 1979. Moored testing, using diveremplaced underwater targets and an external active sonar transducer, was used to investigate specific channels within the sonar array. The test demonstrated that dome echoes were producing errors of up to 4 feet on the deep side in approximately 8 % of the soundings. The worst case condition on outermost beams revealed errors up to 30 % of the depth on the shoal side in 1 % of the soundings. The following sketch (fig. 3) demonstrates this multipath error source. The condition results typically with a return from a hard, flat bottom. A portion of the return echo that is not initially absorbed by the sonar receiver is reflected from the ship's hull, bounces within the sonar dome into the receiver following the initial return. The dome geometry is such that this path is 4.1 feet at

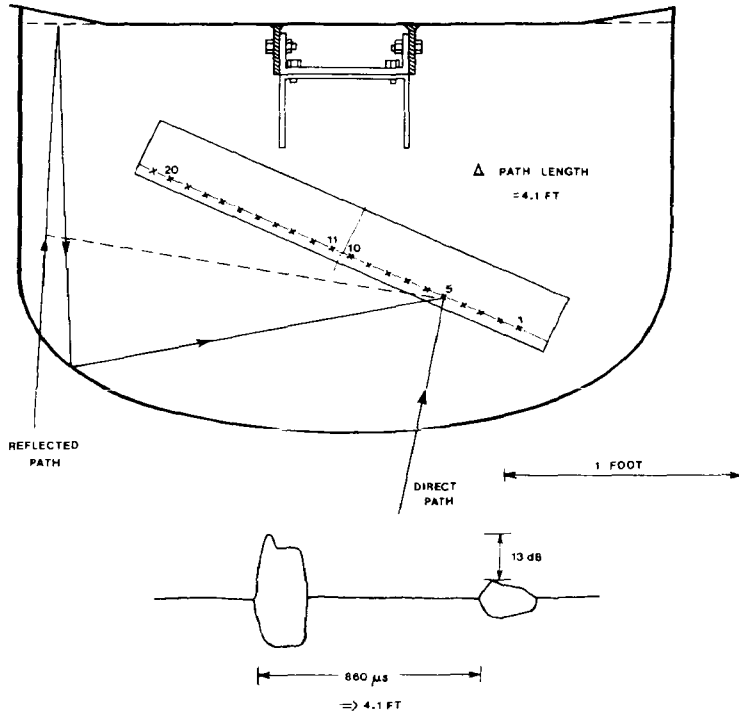

FIG. 3. - Sonar multipath.

maximum. An oscilloscope analysis of direct and reflected echoes from an external source appears as shown at the bottom of the multipath sketch. The ambient water level within the dome was pumped down during this operation, reducing the multipath length and conclusively verifying the echo source as the oscilloscope picture of the 4-foot interval reduced as the water surface was drawn down.

The test results indicate that an echo reduction of the order of 15 dB and some modification of the sonar dome are required to increase its acoustic transparency. A certain sonar absorbent material was tested in February 1980 and found acceptable. A specification has been written for an improved sonar dome and internal application of this material during *Davidson's* next docking for overhaul.

As presently configured, the BS<sup>3</sup> system is physically large. The sonar processor, computer, interface modules, plotters, operator keyboard, etc., occupy approximately 10 cubic metres of space in *Davidson's* plotting room. The transducer and HRP sensor weigh 250 kg and 100 kg respectively and require permanent mounting in the hull of the ship. The 18-metre *Laidly* represents about the smallest size survey launch that can accommodate the present BS<sup>3</sup>. However, a major amount of NOS nautical charting activity is conducted by survey launches of approximately half *Laidly's* size. Future considerations for multi-beam survey systems include retaining present BS<sup>3</sup> data design specifications but packaged to



be more readily transportable aboard the standard size NOS hydrographic survey launch. An economic analysis of U.S. sea lanes and harbor approaches is also underway to determine those areas where the charting potential of the BS<sup>3</sup> can be best exploited. It is envisioned that multi-beam survey techniques can be combined in selected areas with conventional acoustic and photogrammetric systems to produce a more cost-effective survey than is presently available.

### REMOTE SENSING IN THE 80s

As we start a new decade it seems fitting to reflect on the past decade and express some hopes for the new, both as regards remote sensing in general and for the Society in particular. In the 70's remote sensing was in its infancy, attempts being made worldwide to convince governments that it was a tool which could help solve some of the problems of inventory and monitoring of the earth's resources and contribute to the understanding of the oceans. It could also be called the Landsat era, when close on a million scenes of the earth's surface were received by Landsat ground stations worldwide, almost half of which are in the US inventory at Sioux Falls and all of which are available for purchase. As we enter the 80's we have become increasingly aware of the problems this vast amount of data brings in preprocessing, correction, storage and distribution, and it will only be when those problems are solved that the other problems of data interpretation can truly begin and reliable inventories, maps, etc. made. The 80's will be the era of the digital data and of more rapid communication as the advances in computer techniques and use of microprocessors become widespread, and I can envisage that by the end of this decade it will be possible to monitor the environment in a timely way. Training of personnel, the manufacture of cheap and simple equipment for the interpretation of digital data by less highly trained staff is essential if the developing countries are to use remote sensing techniques without aid from the more highly developed countries. The more sophisticated sensors aboard Landsat D and SPOT and other remote sensing satellites of the 80's with their greater resolution will inevitably limit the general availability of data unless some formula acceptable to all countries can be achieved within the United Nations. Steps have already been taken in the USA which may lead to civil control of a series of operational remote sensing satellites, but I see the 80's as a period of further research, searching for the best combination of sensors for such an operational system and solving the data handling problems, in particular those involving radar data, rather than one which will see a civil operational system established worldwide. Progress is however very rapid, and I may have underestimated its pace.

Extract from Editorial in Newsletter No.24 of the Remote Sensing Society.