

IMPLEMENTATION OF THE HYDROGRAPHIC DATA ACQUISITION AND PROCESSING SYSTEM (HDAPS) IN THE NOAA FLEET

by N.E. PERUGINI, T.R. WADDINGTON, G.T. NOLL (*)

Abstract

The U.S. National Oceanic and Atmospheric Administration (NOAA) has developed an automated system for acquiring and processing hydrographic field data in support of its charting mission. The Hydrographic Data Acquisition and Processing System (HDAPS) addresses NOAA's broad requirement to conduct hydrographic surveys in the coastal waters of the U.S. Systems have been successfully deployed on ships, launches, and small boats.

Two types of HDAPS data acquisition systems (DAS) are presented. The first system, based on Hewlett-Packard (HP) hardware, is deployed on ships and launches. The second type is a small boat, 24-volt system, based on IBM-PC compatible hardware. Both types of DAS are capable of conducting echo sounding and side scan sonar surveys. Data acquired by both systems are processed on an HP-based data processing system.

INTRODUCTION

The Hydrographic Data Acquisition and Processing System (HDAPS) has become the fleet standard for the hydrographic survey vessels of the U.S. National Oceanic and Atmospheric Administration (NOAA). The system is designed to acquire and process hydrographic data in the field in support of NOAA's charting mission. At its inception in 1987, HDAPS was specifically designed to meet the survey requirements for the 27-meter NOAA Ships RUDE and HECK. Since that time, HDAPS has evolved into a system which addresses the broad scope of NOAA hydrography. Data acquisition systems are now in place aboard 6.5-meter MonArk survey vessels as well as the 70-meter NOAA ship RAINIER.

(*) NOAA Hydrographic Surveys Branch, Rockville, MD, USA.

HDAPS was originally provided to NOAA under a contract with the Danish firm, Navitronic AS. In March 1987, the first HDAPS prototypes were installed aboard the NOAA ships RUDE and HECK. The primary mission of these vessels, at the time, was to perform side scan sonar surveys. Over the last four years, the system has evolved in such a way that it is now capable of performing basic echo sounding surveys in a shipboard and launch environment. In addition, a second small boat data acquisition system (DAS) has been provided by Navitronic US under the same contract. With the completion of the original contract in 1989, NOAA is now supporting the system and developing new capabilities.

NOAA'S CHARTING MISSION

A brief description of NOAA's nautical charting mission will be helpful in understanding the development of HDAPS. NOAA is responsible for acquiring and processing hydrographic data for the purpose of creating or updating nautical charts which cover the coastal waters of the United States and its possessions. To this end, NOAA must conduct many different types of hydrographic surveys ranging from large-scale harbor surveys to small-scale offshore surveys. Some surveys require depths to be recorded using a standard echo sounder while other surveys require ensonification of the bottom by side scan sonar. Surveys conducted by NOAA can be categorized as follows:

- **Basic Hydrographic** — A scheme of sounding lines is run throughout an area at a line spacing density which is in accordance with the International Hydrographic Organization (IHO) Standard, SP44. Depths are measured by single or dual beam echo sounders. No side scan sonar is towed during main scheme work. Features from prior surveys and those discovered during the current survey are investigated for charting significance. Shoreline manuscripts which have been compiled photogrammetrically, are checked for validity. These surveys are performed by all hydrographic vessels in the NOAA fleet.
- **Basic Hydrographic with Side Scan** — A scheme of sounding lines is run by a vessel towing a side scan sonar in such a way that the survey area receives 200 percent side scan sonar coverage. The survey area is typically an approach to a major harbor. Echo sounding data are also acquired in accordance with basic hydrographic standards. Side scan sonar contacts are logged, interpreted and plotted on an overlay. A determination is made concerning the charting significance of each contact and a recommendation is made for further investigation. This type of survey is usually conducted by a ship which can conduct 24-hour operations.
- **Reconnaissance/Item Investigations** — Features such as charted wrecks, obstructions or contacts discovered on other side scan sonar surveys are investigated during this survey. An example of one feature might be a charted submerged wreck, position approximate, first reported twenty

years ago. The field unit must either find the wreck or disprove its existence. In order to disprove its existence, a side scan sonar search must be undertaken. Typically, this search might require 200 percent bottom coverage within a 1500-meter radius circle whose center is located at the reported position of the feature. Significant side scan sonar contacts are investigated by echo sounder and by divers.

Data acquired by the field are processed in such a way that position, depth and systematic errors are removed from the data. Final field plots are generated which most accurately represent the data acquired. The data are then transmitted to either the Atlantic Hydrographic Section (AHS) in Norfolk, Virginia, or the Pacific Hydrographic Section (PHS) in Seattle, Washington, for further processing. At the Hydrographic Sections, cartographers check the data to ensure that the survey meets standards. In addition, the hydrographers recommendations concerning specific charting features are validated. A 'smooth sheet' is constructed for basic surveys. From this document, chart compilers at NOAA headquarters in Rockville, Maryland, select representative depths and features to be displayed on the nautical chart.

NOAA FIELD UNITS

The following is a brief description of those NOAA field units currently involved in hydrographic surveys:

- RAINIER — Based in Seattle, the RAINIER is a 70-meter vessel equipped with four 9-meter Jensen survey launches. RAINIER conducts basic hydrographic surveys in Alaska.
- RUDE and HECK — These 27-meter survey vessels based in Norfolk, work mostly on item investigation surveys along the U.S. east coast and in the Gulf of Mexico.
- WHITING — This 50-meter survey vessel, based in Norfolk, has been used for area coverage surveys. In the past several years, the WHITING has performed area surveys in the approaches to New York Harbor and Chesapeake Bay.
- Atlantic Hydrographic Party — This mobile field party, based in Norfolk, conducts basic surveys with six 6.5 meter MonArks. These vessels can be transported by boat trailer. In 1990, the field party conducted inshore basic hydrographic surveys in Corpus Christi, Texas, and Long Island, New York.
- Pacific Hydrographic Party — This mobile field party, based in California, is currently working on basic surveys in the Sacramento River, California. Survey launches include a 6.5-meter MonArk and a 9-meter Jensen.

SENSORS USED BY NOAA

In the context of designing and implementing a new data acquisition system, NOAA is fortunate that its field units use a standardized suite of sensors. Each field unit mentioned above may have some or all of the following equipment.

ECHO SOUNDERS

- Raytheon DE-719B/C with Odom Digitrace Digitizer
- Innerspace 448 Echo Sounder
- Raytheon DSF-6000N Dual Beam Echo Sounder

POSITIONING SYSTEMS

- Motorola Falcon 484
- Cubic ARGO
- Krupp Atlas Polarfix

OTHER SENSORS

- Datawell Hippy Heave Roll and Pitch Sensor
- Gyro
- EG&G Model 260 Side Scan Sonar

HDAPS DATA ACQUISITION SYSTEMS

Two types of DAS are supported by HDAPS. The first is based on Hewlett-Packard hardware and referred to as the HP-DAS. The second type is based on IBM-PC compatible hardware and called the PC-DAS. The HP-DAS is a 110-volt system deployed on ships and 9-meter Jensen launches. The PC-DAS is a 24-volt system used aboard the 6.5 meter MonArks and some Jensen launches. The HP-DAS offers many features such as color graphics displayed on a 40.6 cm monitor, while the PC-DAS is designed to present the hydrographer real time information concisely in a rugged small boat environment.

HP-DAS: SHIP AND LAUNCH SYSTEMS

Hardware Configuration

Figure 1 illustrates the standard HP-DAS hardware configuration that can be found in shipboard or Jensen launch systems. A brief description of HP-DAS hardware components follow.

The HP-340C+ computer has the following features:

- Motorola 68030 CPU, clock speed of 16.7 Mhz
- Motorola 69882 Floating Point Coprocessor, 16.7 Mhz
- Four Mb RAM
- IEEE-488 (HPIB) interface used for peripherals
- Fast HPIB or Small Computer System Interface (SCSI) interface for fast data disk access
- 40.6 cm high-resolution color monitor
- 1024 × 768 6-plane high-resolution color graphics board

Navitronic's Hyflex 1000 is the interface between computer and sensors. The Hyflex is an intelligent device, controlled by a Z80 microprocessor, and is capable of performing various operations on the incoming data before it is processed by the survey computer. The major functions of the Hyflex are time tagging and buffering of incoming data as well as outputting annotation, initialization parameters, and vessel speed to various instruments.

The basic Hyflex unit consists of a 48.2 cm rack-mountable chassis with 15 slots, numbered 0 to 14 for accepting a variety of interface cards. The Hyflex chassis has no processor itself, but uses various cards, called option boards, installed in the slots. There are three boards that must be installed for the Hyflex to operate. Slot 0 is reserved for the power supply board. For ship and launch systems, 110-volt AC power supplies are used. The Option 00 board is the Hyflex processor board and is normally installed in slot 1. The third board necessary for operations is the System I/O board, Option 01. This board handles the communication between the Hyflex and the survey computer via the HPIB (IEEE-488) interface.

Navitronic's Path Guidance Unit (PGU) houses a steering meter, two LCD displays, and a numeric keypad in a splashproof container. The PGU functions as both a remote steering display for the helm, and as a control device for the HDAPS. The functions of the keys on the PGU are programmed in the HDAPS software. Most keys control the type of data being displayed. For example, the operator can display vessel position, off track error, speed, and depth on the PGU. In addition, the operator can begin, break, and update survey lines by pressing buttons on the unit.

Figure 1 illustrates the standard sensors which can interface with the Hyflex. With the exception of the stepper gyro compass, sensors communicate with the Hyflex via RS-232. The HP-DAS does not require the presence of all sensors shown in Figure 1 in order to operate. For example, launch systems are not equipped with gyro compasses or heave, roll, and pitch sensors. The minimum configuration consists of one echo sounder and one positioning system. In addition to those shown, other sensors such as STARFIX, QMIPS, and the Seatrac Integrated Navigation System have interfaced with HDAPS.

The HP-DAS supports several different types of HP printers and the 61.0 cm and 91.4 cm Bruning Zeta plotters which are connected via the HPIB bus.

HP-DAS Software and System Operation

The operating system for the HP hardware is HP's Rocky Mountain Basic (RMB). Applications have been written by the original contractor, Navitronic A.S., and NOAA for data acquisition, data processing, and file management. RMB is a proprietary, interpretive language, and is especially suited for use with an instrument controller. In many respects, it is very much like FORTRAN. The advantages of using a high-level, non-compiled language include: 1) In-house development capabilities with little training, 2) Implementation of field changes without a separate compilation process, and 3) Faster debugging of test code. RMB also has many powerful and easy to use graphic commands which have been incorporated into most HDAPS applications.

All HDAPS software is menu driven. The software self-starts when the system is first powered on. From the Main Menu, the operator may select one of six general program functions: Pre-Survey, Survey, Post-Survey, Diagnostics, File System, and Utilities.

As its name implies, the Pre-Survey function is used to specify survey parameters and related information prior to conducting survey operations. Within various Pre-Survey tables, the operator may set project limits, create survey plotter sheets, define the family of survey lines to be run, list all horizontal control information, and enter all horizontal and vertical correctors (e.g., vessel offsets, electronic correctors, tide correctors, and sound velocity correctors). Most of the Pre-Survey information can be entered prior to the start of a project, though certain tables will need to be updated throughout the project. For instance, predicted tide and sound velocity tables will have to be entered, new control stations may have to be added, and updated electronic correctors may be needed.

The Survey function is used to access the data acquisition mode of HDAPS. Before beginning data acquisition, the operator must enter the Set-up Survey function to define the default parameters which will be used in the survey mode. This will define the tables, peripherals, and positioning system, as well as the various data acquisition parameters such as logging interval, selected sounding interval, and survey line orientation. After defining the various set-up parameters, the operator may enter the Survey mode.

Upon selecting the Survey mode, the system will first check the validity of the tables which were specified in Set-up Survey. After all of the tables have been verified, the system will attempt to initialize all of the selected peripherals and display their status. If all the peripherals were successfully initialized, the system will enter the Survey mode and the primary survey screen will appear.

The operator may select one of 12 screen displays to view some aspect of the real-time data being acquired. The default page displays most of the pertinent survey information, and the operator may access many of the commonly changed parameters from this screen. The other pages may be accessed at any time, and they generally provide a more detailed view of a particular aspect of the data. For instance the Position Quality page provides detailed positioning information including graphic presentations of lines of position (LOP) geometry and quality. The Track Plot page provides a screen depth plot of the current line and all preceding lines. By using a set of system-defined function keys, the operator may

start and stop survey lines, take detached positions, identify and log side scan sonar contacts, update survey parameters, download survey data, and exit the survey routine.

Data is normally logged at one second intervals to RAM or hard disk. Typically, at the end of a data acquisition period, the data are down loaded to a high density 1.4 Mb floppy disk. These data will subsequently be uploaded on to the DPS hard disk. In this way, the floppy disk serves as a raw data backup. Once the survey has been processed completely, the floppy disks are reused.

The 320-character HDAPS data record includes the following types of information: vessel Easting and Northing, four primary and two secondary lines of position, electronic range correctors, five high and five low frequency depths, sound velocity correction, dynamic draft, and tide correctors, digital heave, side scan sonar parameters and other available sensor information.

The HP-DAS uses an algorithm which computes filtered positions by combining line of position data with the vessel's unique acceleration characteristics. A priori standard deviations are assigned to individual lines of position, the gyro compass (if available), and the vessel's acceleration parameters. With this information, a constrained least squares position is computed once a second. The system can work in a multi-range or hyperbolic mode. Four primary lines of position can be used to compute the primary position and in addition, two secondary lines of position can also be recorded for use in post processing. The system accommodates the mixing of Falcon and ARGO lines of position.

Standard methods for calibrating ARGO and Falcon positioning systems are available. These include, three-point sextant fix, range-azimuth fix, baseline crossing, and an ARGO calibration by Falcon. HDAPS uses two key indicators to monitor the quality of positions during data acquisition. These indicators are the 95 percent error circle radius (ECR) and the maximum residual of the position. The ECR is a measure of the foundation or geometry of the position, while the maximum residual is an indicator of the quality of observations.

The operator monitors data acquisition quality by examining real time output from peripherals. For example, while towing a side scan sonar, the operator may opt to produce a track, depth or swath plot on the plotter. At selected time intervals, pertinent data will be output to the printer. Warnings such as 'BAD POSITION QUALITY' or 'SIDE SCAN FISH HEIGHT LESS THAN 8 PERCENT OF RANGE SCALE' are flashed on the monitor when data quality degrades.

PC-DAS: SMALL BOAT SYSTEM

Hardware Configuration

While the HP-DAS was designed for the relatively stable and spacious environment of ships and launches, the PC-DAS is a more portable unit used in the rugged confines of NOAA's small boats. The standard small boat used by NOAA field parties is the 6.5 meter MonArk, an aluminium, tri-hulled, flat bottom boat equipped with a 150-HP outboard motor and a small enclosed cabin area which provides less than total protection from the outside elements. Figure 2 illustrates the hardware configuration for a PC-DAS installation.

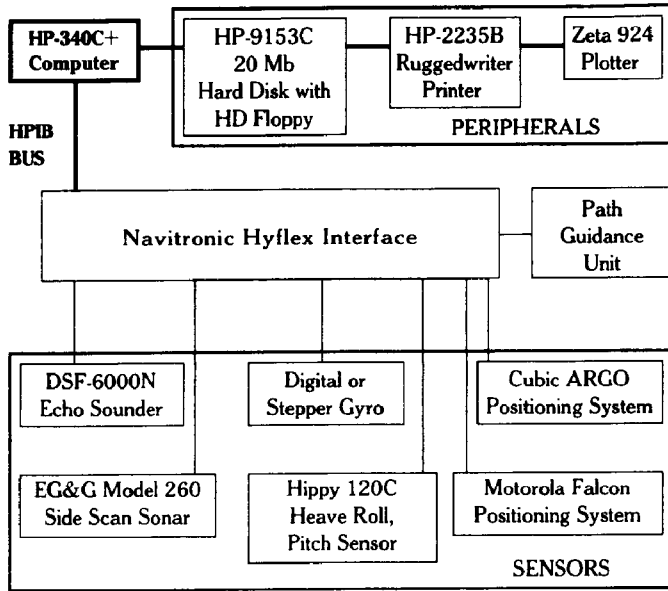

FIG. 1.— HP Data Acquisition System

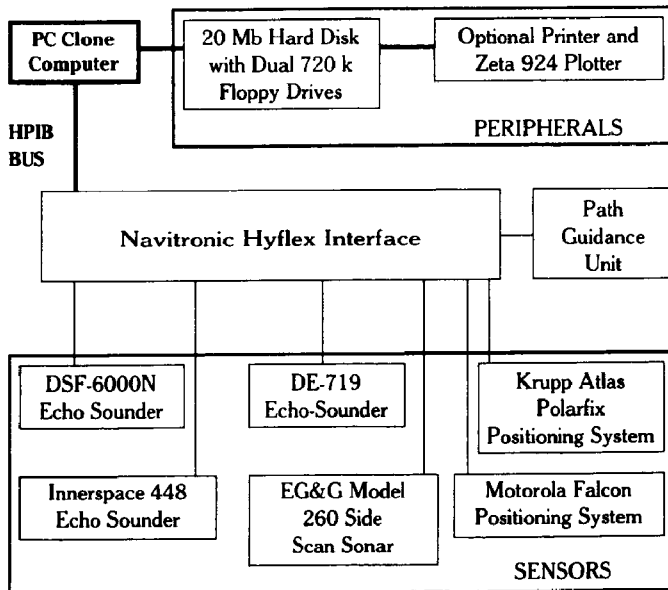

FIG. 2.— PC Data Acquisition System.

The heart of the PC-DAS is basically an IBM-PC clone with a commercially available hard disk which has been shock-mounted in a sturdy enclosure. The computer uses a 20 Mb hard disk for storage of software, data tables, and survey data and also has two 3.5" floppy disk drives with a capacity of 720 Kb. In addition, the survey computer is equipped with a HPIB board to allow high-speed interfacing with the Navitronic Hyflex unit.

A Liquid Crystal Display (LCD) screen mounted on the launch dash is used for information display. Individual LCD panels have been packaged in an aluminium frame so that they may be mounted within the launch. The LCD screens use very little power, are easily viewed in bright sunlight and have proven to be reliable.

Like the HP-DAS, the Hyflex serves as an intelligent sensor interface. With the PC-DAS an Option 24 power supply board (24-volt DC) is installed in lieu of the Option 110 board found on the HP-DAS. A Path Guidance Unit is available with the same features that are available to the HP-DAS.

The survey computer, Hyflex, and Falcon Range Processing unit are all rack-mounted within a watertight, shock-proof military enclosure, manufactured by Skydyne, which provides protection from sea, spray, rain, and excessive pounding. With the exception of the echo sounder, which required 12-volt DC power, each of the survey hardware units operate off of 24-volts DC. The echo sounder is powered by the 12-volt battery which is also used to crank the engine and power the launch radio, lights, and horn. The 24-volt power is provided through two 12-volt batteries connected in parallel. Using a special power inverter, the engine alternator is able to alternately recharge both the 12-volt and 24-volt systems, thereby eliminating the need to replace batteries on a daily basis.

PC-DAS Software and System Operation

The PC-DAS software is written in Microsoft QuickBasic; it is compiled, and runs under DOS. Navitronic U.S. provided and currently maintains the software under a contract with NOAA. The menu structure is modeled after the HP-DAS. The operator must enter project and vessel parameters in a Pre-Survey mode and specify the peripheral and sensor configuration in a Survey Setup mode.

In the Survey mode, the operator monitors data acquisition by viewing information on one screen. Information such as depth and position can also be viewed by the helmsman on the Path Guidance Unit. The operator initiates actions such as data logging and line updating with the use of keyboard function keys. Some of these functions can also be initiated on the Path Guidance Unit. Turning lines of position on or off, changing the sounding interval, issuing Polarfix commands, and altering all other survey-related parameters is done in a 'Change' environment which can be invoked at any time from within the survey routine.

Data can be logged at one second intervals in a 130 character record format. Data are logged to a file on the hard disk containing no more than 4700 records, the equivalent to the capacity of a 720 Kb floppy disk. Upon completion

of data acquisition, software developed by Oswego Software Inc. is used to convert the PC ASCII file into an HP LIF file. During this process, the file is also copied from the hard disk to floppy disk for subsequent transfer to the trailer-based processing system.

The multi-range positioning algorithm used by the PC-DAS is a basic least squares computation. Rather than filtering positions as in the HP-DAS, the PC-DAS employs an LOP editor to check the adequacy of Falcon ranges before computing a position.

Two types of range-azimuth positioning systems can be employed. The first involves the use of the Polarfix, an automatic range-azimuth tracking device. Commands such as 'GO TO A PICKUP POINT' or 'CHECK INITIAL' are issued to the Polarfix through the PC-DAS. The PC-DAS in turn computes survey northings and eastings from Polarfix range and azimuth data telemetered from shore, providing the helmsman with straight-line steering instructions. The second type of range-azimuth positioning involves establishing the vessel's position with a Falcon range and a theodolite direction. The theodolite observer radios observations to the vessel's PC-DAS operator at specified time intervals. Upon receipt of the observations, the PC-DAS operator enters the data into the computer. Meanwhile, Falcon range data are being recorded with no delay. The helmsman must follow either range arcs or azimuth lines since positions are not computed in real time due to the delayed angle entry. Ranges and angles are merged in Post-Survey and the vessel positions are computed at that time.

Although the PC-DAS can support a plotter and printer, these peripherals normally are used only when the system is installed on vessels larger than the MonArk which are able to provide AC power. Likewise, due to size considerations, the side scan sonar is used only sparingly aboard the MonArk. The DE-719B echo sounder equipped with an Odom Digitrace and the Innerspace echo sounder are the standard units used aboard the MonArk, while larger launches can accommodate the DSF-6000N.

HDAPS DATA PROCESSING SYSTEM

DATA PROCESSING SYSTEM HARDWARE

Figure 3 illustrates the hardware components which make up the Data Processing System (DPS). The HP-DPS accommodates data from both the PC-DAS and HP-DAS. A summary of the data flow for both the HP-DAS and the PC-DAS is provided in Figure 4. Many of the DPS components are the same as those found in the HP-DAS. Aboard the NOAA Ships RUDE and HECK, the same hardware is used for both data acquisition and data processing. On the RAINIER, the WHITING, and the field parties, separate DPS work stations are used.

DATA PROCESSING SOFTWARE

Like the HP-DAS, DPS software is written in HP BASIC, the underlying operating system being HP Work Station (WS) BASIC. Two major environments make up the data processing software. The first is the File System. This software enables the operator to upload data, save it in a hierarchical file system, access it for processing, and then download it on to a transportable media. The second environment is the processing application software. This allows the operator to perform the required processing functions such as editing, plotting, and listing data.

The File System's first function is to upload data from the DAS floppy disk on to the DPS hard disk. If the data originates from the PC-DAS, the 130-character PC data format is automatically converted into the 320-character HP format. Once this has been done, the DPS treats data acquired by the HP-DAS and the PC-DAS in the same fashion. Because the floppy disks were automatically and systematically labelled by the data acquisition system, the File System is programmed to know where to put the data on the hard disk. A hierarchical file system based on the following strata is used:

- Project
- Sheet
- Vessel
- Day Number

Once the data are on the hard disk, a sheet or project can be backed up on to a 32-track cartridge tape. Processed field data is also transmitted to the marine centers in this form.

The operator has the ability to perform the basic tasks of plotting, listing and editing data in the Post-Survey environment. Track, depth or swath plots can be made with the use of the 8-pen color plotter. The color by depth option is useful for evaluating contours in a basic hydrographic survey. Sound velocity, tide, draft, and settlement and squat corrections can be reapplied to raw data during plotting.

Depth editing is performed in a color-graphic edit mode which displays the bottom profile, or alternately, in a 'Quick Edit' batch mode. Positions can be edited in a graphic editing environment. Recently, software has been developed to recompute positions in the event that real time positions were not properly computed. This position recomputation enables the operator to apply new baseline correctors to raw range data or compute new positions with new shore station coordinates.

SYSTEM SUPPORT AND MAINTENANCE

With the exception of Navitronic's Hyflex and PGU, all HDAPS hardware are readily available 'off the shelf.' HP and PC hardware performance has been reliable, with only a few failures occurring during the 1990 field season. Particularly impres-

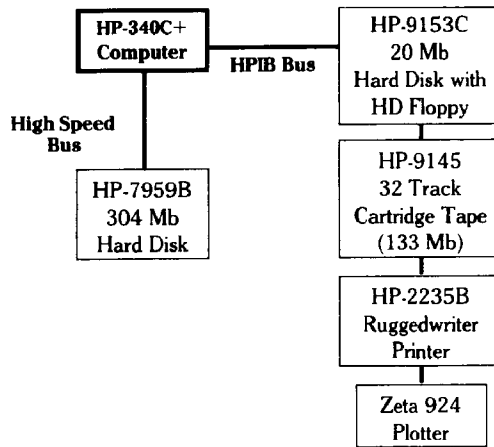

FIG. 3.— HDAPS Data Processing System.

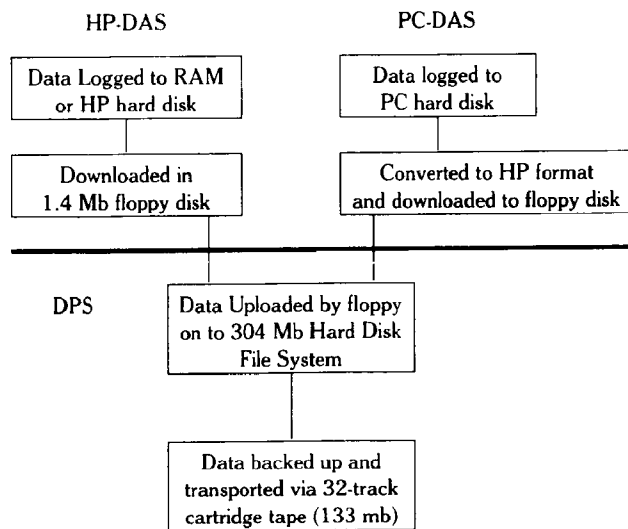

FIG. 4.— HDAPS Data Flow.

sive is the performance of the hard and floppy disk drives on both the small boat and launch systems. These vessels take a great deal of pounding on a daily basis.

HDAPS software maintenance and development is provided by NOAA's Hydrographic Surveys Branch, Rockville, Maryland. Software deficiencies encountered by a ship at sea or a field party in a remote location are reported by phone or letter to this office. It is not unusual for HDAPS programmers to talk the field operator through a programming change over the phone in order to remedy the immediate problem. New versions of the software are issued on a regular basis.

NOAA programmers are continuing to make enhancements to the HP data acquisition and processing software. In the future, we are looking at the possibility of running HP software under a UNIX operating system. In this way, we may be able to network data processing systems aboard ship or wherever needed.

CONCLUSIONS

HDAPS fulfills NOAA's requirements for an automated hydrographic data acquisition and processing system capable of deployment on ship, launch or small boat. Since its first deployment in 1987, HDAPS equipped vessels have acquired thousands of miles of sounding line and side scan sonar data. The sheer quantity of hydrographic data acquired and processed is a testimonial to the system's reliability.

In designing and implementing HDAPS, the following tenets were established.

- To the extent possible, use proven off the shelf hardware. The HP and PC-compatible hardware has been reliable and is relatively inexpensive. Hardware for the HP systems have been upgraded twice in four years, each time greatly enhancing system performance.
- Take every measure to ensure that sensor data are noise-free during data acquisition. It is easier to write software to help the operator monitor data quality during data acquisition than to rectify problems in processing.
- The system is designed to be used as a tool for the field hydrographer, it should not inhibit the hydrographer's ability to interpret data. Although many of the tedious numerical processes associated with a hydrographic survey have been automated, the important task of data interpretation still exists.
- All raw data are recorded so the survey can be re-built in post processing.
- Until noise-free sensors and perfect algorithms are invented, hydrographers must have the ability to intervene in automated 'black box' processes. Hydrographers, not computer programmers, must have the last word in system design.

References

- [1] BROWN M.B., WALLACE J.L.: Hydrographic Data Acquisition and Processing System (HDAPS), Proceedings — U.S. Hydrographic Conference '88, May 1988.
- [2] WADDINGTON T.R.: Adapting HDAPS to Meet National Ocean Service Hydrographic Field Party Needs, Proceedings — U.S. Hydrographic Conference '90, May 1990.